

CAT-2024



# ELECTRONIC COMPONENTS

- Electric Double Layer Capacitors (Green-Cap)
- Conductive Polymer Hybrid Capacitors
- Conductive Polymer Electrolytic Capacitors
- Surface Mount Aluminum Electrolytic Capacitors
- Miniature Aluminum Electrolytic Capacitors
- Large Aluminum Electrolytic Capacitors



**1**

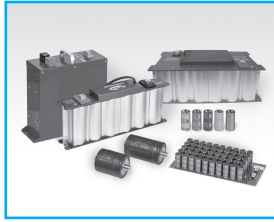

**Green-Cap  
(ELECTRIC DOUBLE LAYER  
CAPACITORS)**

**21**

**2**



**CONDUCTIVE POLYMER  
HYBRID ALUMINUM ELECTROLYTIC  
CAPACITORS**

**37**

**3**

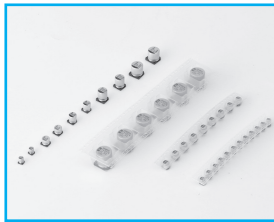

**SURFACE MOUNT  
ALUMINUM ELECTROLYTIC  
CAPACITORS**

**55**

**4**



**MINIATURE  
ALUMINUM ELECTROLYTIC  
CAPACITORS**

**85**

**5**



**LARGE  
ALUMINUM ELECTROLYTIC  
CAPACITORS**

**179**

# SERIES CHART

## Green-Cap (ELECTRIC DOUBLE LAYER CAPACITORS)

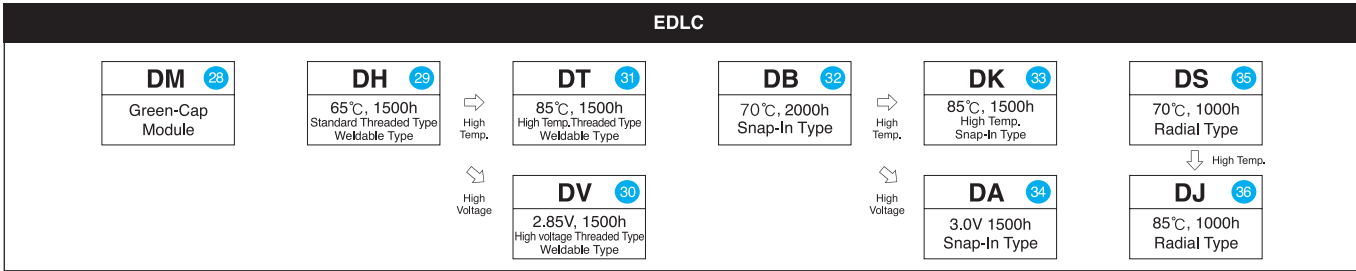

## Conductive polymer hybrid aluminum electrolytic capacitors

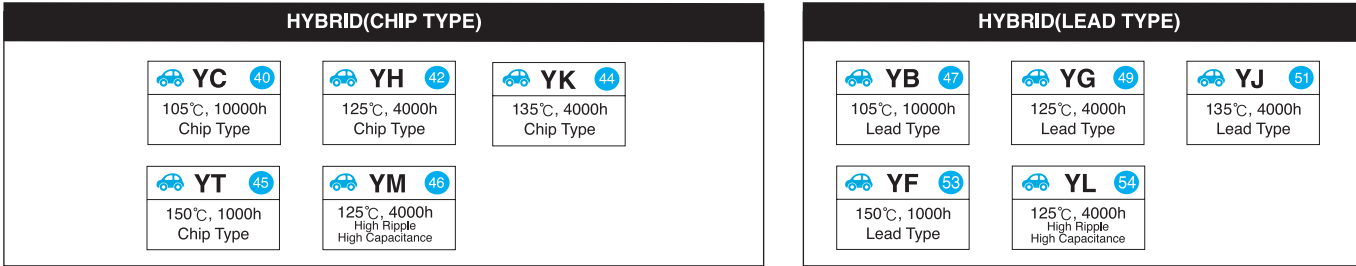

## ALUMINUM ELECTROLYTIC CAPACITORS

### CHIP TYPES

: AEC-Q200 compliant

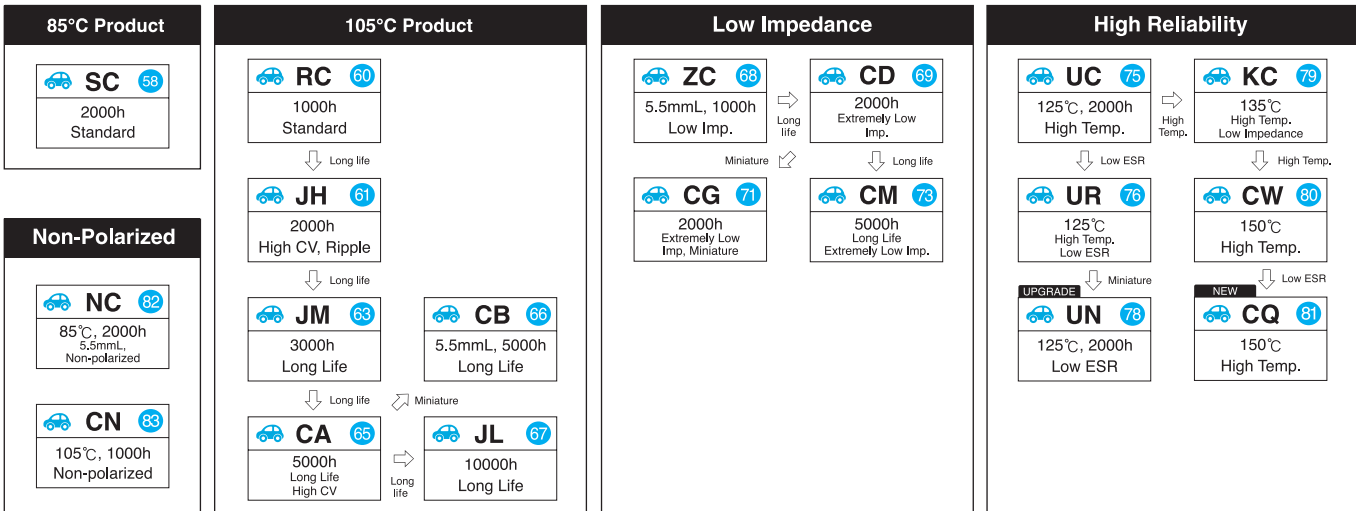

### MINIATURE RADIAL LEAD TYPES

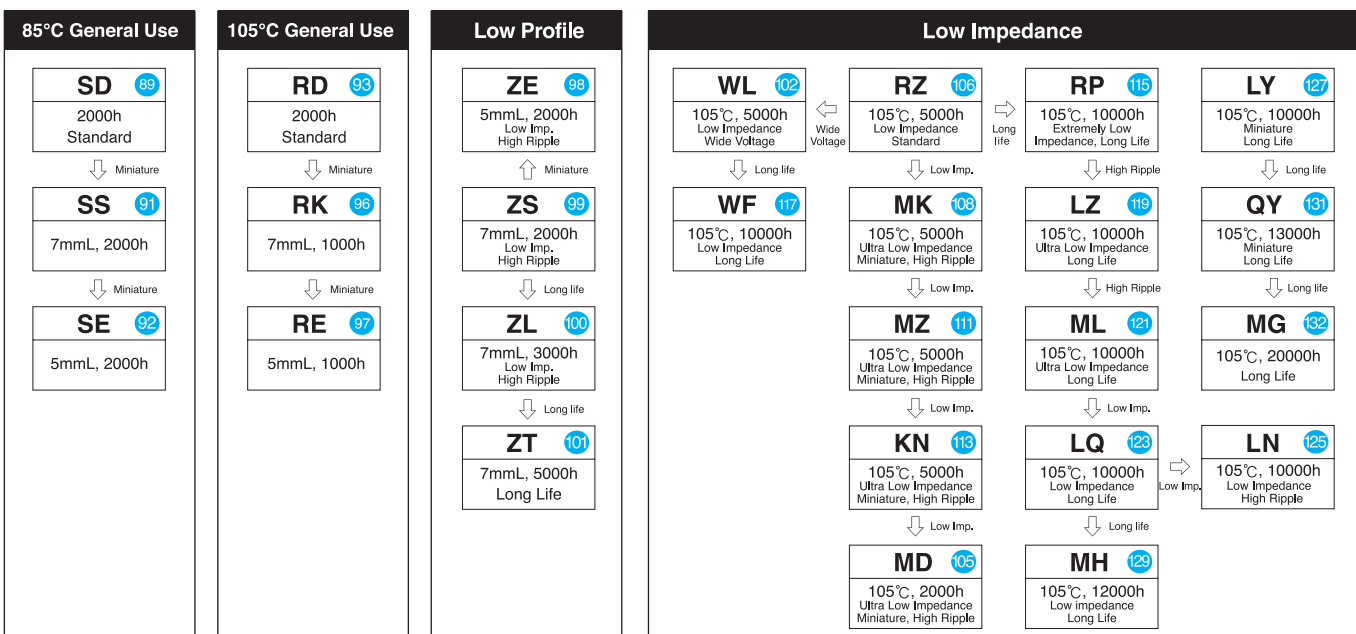

## ■ ALUMINUM ELECTROLYTIC CAPACITORS

### ● MINIATURE RADIAL LEAD TYPES

PSU, SMPS, Adapter			High Temperature		Special Applications	
<b>KS</b> 133 85°C, 8000h Ultra Low Impedance Miniature, High Ripple	<b>BN</b> 143 105°C, 12000h Long Life -40°C Assurance High Ripple		<b>RB</b> 153 125°C, 2000h High Temperature	<b>WP</b> 156 125°C, 5000h High Temp.	<b>MW</b> 165 105°C, 5000h High Ripple	<b>VP</b> 167 135°C, 3000h For LED High Temp.
	↓ Long Life	↑ Miniature				↓ High Temp.
<b>KA</b> 135 105°C, 3000h	<b>SB</b> 134 85°C, 10000h High Ripple	<b>KJ</b> 146 105°C, 12000h Long Life -40°C Assurance High Ripple	↓ High Ripple Long Life	↑ Low ESR.	<b>LR</b> 166 105°C, 5000h High Capacitance	<b>VQ</b> 169 150°C, 1000h High Temperature
↓ Long Life	↓ High Temp.	↑ High Ripple		<b>UPGRADE</b>		↓ Long Life
<b>RH</b> 137 105°C, 5000h For PSU	<b>BL</b> 142 105°C, 10000h For PSU Long Life	<b>MT</b> 144 105°C, 12000h For PSU Long Life, High Ripple	<b>WT</b> 158 125°C, 5000h High temp. Low Imp. Long Life	<b>BK</b> 162 125°C, 5000h High Temp.		<b>VX</b> 171 150°C, 1000h High Temperature
↓ High Ripple	⇒ Long life	⇒ Long life	⇒ High Ripple	↓ Long Life		<b>NEW</b>
<b>BH</b> 139 105°C, 5000h For PSU High Ripple		<b>MP</b> 149 105°C, 15000h For PSU Long Life		<b>BQ</b> 164 125°C, 5000h High Temp.		↓ Long Life
↓ High Ripple		↓ Long Life		↓ High Temp.		<b>Non-Polarized</b>
<b>KU</b> 140 105°C, 5000h		<b>MJ</b> 151 105°C, 20000h For PSU Extremely Long Life		<b>LJ</b> 160 130°C, 4000h For LED High Temp.		<b>NP</b> 172 85°C, 2000h Standard
						↑ Miniature
						<b>NE</b> 175 5mmL, 1000h
						↓ Miniature
						<b>RN</b> 176 105°C, 1000h Standard
						⇒ Miniature
						<b>NS</b> 174 7mmL, 2 000h

### ● LARGE TYPES

Snap-in Terminal			Screw, Lug Terminal			Special Application	
<b>HC</b> 183 85°C, 2000h Standard	<b>UPGRADE</b> <b>HE</b> 192 105°C, 2000h Standard	<b>JK</b> 195 105°C, 2000h Printer system	<b>GT</b> 216 85°C, 2000h For Inverter	<b>GY</b> 219 85°C, 2000h High Ripple	<b>CU</b> 220 105°C, 2000h Wide Temp.	<b>AL,AY</b> 233 85°C For Air-conditioning system	<b>AK</b> 235 105°C For Air-conditioning system
↓ Long Life	↓ Long Life	⇒ High Ripple	↓ Long Life	⇒ High Ripple	↓ Long Life	↓ High Ripple	↓ Long Life
<b>HJ</b> 186 85°C, 3000h Miniature	<b>HK</b> 196 105°C, 3000h Long Life	<b>HG</b> 199 105°C, 3000h High Ripple Wide Temp.	<b>GF</b> 223 85°C, 5000h For Inverter	<b>GR</b> 225 85°C, 5000h High Ripple	<b>EV</b> 228 105°C, 5000h Long Life	<b>AZ</b> 234 85°C For Air-conditioning system	<b>NEW</b> <b>AQ</b> 236 105°C For Air-conditioning system
↓ Long Life	↓ Long Life	↓ High Ripple	↓ Long Life	⇒ High Ripple	↓ Long Life		
<b>HF</b> 189 85°C, 5000h Long Life	<b>HL</b> 202 105°C, 5000h Long Life	<b>KG</b> 200 105°C, 3000h High Ripple Wide Temp.	<b>GL</b> 227 85°C, 20000h Long Life		<b>EY</b> 229 105°C, 7000h Long Life	<b>LW,SW</b> 230 85°C Welding Machine	
↓ Long Life	↓ High Voltage	↓ High Ripple					
<b>JR</b> 191 85°C, 10000h Long Life	<b>NEW</b> <b>JX</b> 205 105°C, 5000h High Voltage	<b>HH</b> 201 105°C, 3000h Surge Voltage	<b>LM</b> 214 85°C, 2000h Lug Terminal			<b>AM</b> 231 85°C, 2000h For Audio	
	↓ Long Life						
<b>HB</b> 212 125°C, 1000h High Temp.	<b>HY</b> 206 105°C, 7000h Long Life					<b>DF</b> 232 For Photo Flash	
	↓ Long Life						
	<b>JY</b> 208 105°C, 10000h Long Life	<b>JZ</b> 209 105°C, 20000h Long Life					
	⇒ Long Life						



# CONTENTS

## 1 Green-Cap (Electric Double Layer Capacitors)

★ New series  
☆ Upgrade series

Series	Features	Operating Temperature Range(°C)	Voltage Range (VDC)	Capacitance Range (F)	Load Life Time (hours)	Page
DM	Green-Cap Module	Green-Cap modules are supplied on custom-made basis.				28
DH	Axial type, high power density	-40 ~ 65	2.7	1200 ~ 3400	1500	29
DV	Axial type, high power density, high voltage	-40 ~ 65	2.85, 3.0	1200 ~ 3400	1500	30
DT	Axial type, high power density, high temp.	-40 ~ 85	2.5	1200 ~ 3000	1500	31
DB	Snap-in type, standard series	-25(-40) ~ 70(65)	2.5, 2.7	100 ~ 600	2000	32
DK	Snap-in type, high temp.	-40 ~ 85	2.7	100 ~ 400	1500	33
DA	Snap-in type, high voltage	-40 ~ 65	3.0	100 ~ 480	1500	34
DS	Lead type	-30(-40) ~ 70(65)	2.5, 2.7, 3.0	3 ~ 100	1000	35
DJ	Lead type, high temp.	-40 ~ 85	2.5	3 ~ 50	1000	36

## 2 Conductive Polymer Hybrid Aluminum Electrolytic Capacitors

Series	Features	Operating Temperature Range(°C)	Voltage Range (VDC)	Capacitance Range (μF)	Load Life Time (hours)	Page	
SMD	YC	Chip type, HYBRID long life	-55 ~ 105	16 ~ 100	10 ~ 560	10000	40
	YH	Chip type, HYBRID high temp.	-55 ~ 125	16 ~ 100	10 ~ 560	4000	42
	YK	Chip type, HYBRID high temp.	-55 ~ 135	25 ~ 63	33 ~ 470	2000 ~ 4000	44
	YT	Chip type, HYBRID ultra high temp.	-55 ~ 150	25 ~ 63	15 ~ 330	1000	45
	YM	Chip type, HYBRID ultra high temp. high ripple	-55 ~ 125	16 ~ 63	47 ~ 820	4000	46
LEAD	YB	Lead type, HYBRID long life	-55 ~ 105	16 ~ 100	10 ~ 560	10000	47
	YG	Lead type, HYBRID high temp.	-55 ~ 125	16 ~ 100	10 ~ 560	4000	49
	YJ	Lead type, HYBRID ultra high temp.	-55 ~ 135	25 ~ 63	33 ~ 470	2000 ~ 4000	51
	YF	Lead type, HYBRID ultra high temp.	-55 ~ 150	25 ~ 63	15 ~ 330	1000	53
	YL	Lead type, HYBRID ultra high temp. high ripple	-55 ~ 125	16 ~ 63	47 ~ 820	4000	54

## 3 Surface Mount Aluminum Electrolytic Capacitors

Series	Features	Operating Temperature Range(°C)	General	Miniature	Long Life	Solvent Proof	Voltage Range (VDC)	Capacitance Range (μF)	Load Life Time (hours)	Page	
SMD	SC	Standard	-40 ~ 85	●			●	4 ~ 450	1.0 ~ 2200	2000	58
	RC	Standard, wide temp.	-55 ~ 105	●			●	6.3 ~ 50	1.0 ~ 1000	1000	60
	JH	Chip type, high ripple	-55(-40) ~ 105				●	6.3 ~ 400	3.3 ~ 2200	2000	61
	JM	Chip type, long life	-40 ~ 105			●	●	6.3 ~ 400	2.2 ~ 2200	3000	63
	CA	Chip type, long life	-55(-40) ~ 105			●	●	6.3 ~ 50	10 ~ 1000	5000	65
	CB	Chip type, long life, 5.5mmL height	-40 ~ 105		●	●	●	4 ~ 50	1.0 ~ 100	5000	66
	JL	Chip type, long life, for ECU	-40 ~ 105			●	●	10 ~ 50	33 ~ 470	10000	67
	ZC	5.5mmL chip type, low Impedance	-55 ~ 105				●	6.3 ~ 35	1.0 ~ 100	1000	68
	CD	Chip type, extremely low Impedance	-55 ~ 105				●	6.3 ~ 100	10 ~ 1500	2000	69
	CG	Chip type, extremely low Impedance, miniature	-55 ~ 105		●		●	6.3 ~ 80	100 ~ 2200	2000	71
	CM ☆	Chip type, extremely low Impedance, long life	-55 ~ 105			●	●	6.3 ~ 100	2.2 ~ 3300	3000 ~ 5000	73
	UC	Chip type, high temp. for 125°C use	-40 ~ 125				●	10 ~ 400	3.3 ~ 1000	2000	75
	UR	Chip type, high temp. low ESR. for 125°C use	-40 ~ 125		●	●	●	10 ~ 400	1 ~ 1000	1000 ~ 5000	76
	UN ☆	Chip type, low ESR for 125°C use	-40 ~ 125				●	10 ~ 63	33 ~ 680	3000	78
	KC	Chip type, high temp. for 135°C use, low ESR	-40 ~ 135				●	10 ~ 35	47 ~ 470	2000	79
	CW	Chip type, high reliability	-40 ~ 150				●	10 ~ 50	33 ~ 1000	2000	80
	CQ ☆	Chip type, high temp. low ESR	-40 ~ 150				●	25 ~ 35	150 ~ 270	1500 ~ 2000	81
	NC	5.3mmL chip, non-polarized	-40 ~ 85				●	6.3 ~ 50	1.0 ~ 47	2000	82
	CN	Chip type, wide temp. non-polarized	-55(-40) ~ 105				●	6.3 ~ 50	1.0 ~ 47	1000	83

4 Miniature Aluminum Electrolytic Capacitors

★ New series  
☆ Upgrade series

Series	Features	Operating Temperature Range (°C)	General	Miniature	Long Life	Solvent Proof	Voltage Range (VDC)	Capacitance Range (μF)	Load Life Time (hours)	Page	
General Type(85°C)	SD	Standard	●			●	6.3 ~ 500	1.0 ~ 22000	2000	89	
	SS	Standard, height 7mmL		●		●	4 ~ 63	1.0 ~ 220	2000	91	
	SE	Standard, height 5mmL		●		●	4 ~ 63	1.0 ~ 330	2000	92	
General Type(105°C)	RD	Standard, wide temp	●			●	6.3 ~ 500	2.2 ~ 22000	1000 ~ 2000	93	
	RK	Wide temp. range, height 7mmL		●		●	4 ~ 63	1.0 ~ 68	1000	96	
	RE	Wide temp. range, height 5mmL		●		●	4 ~ 50	1.0 ~ 220	1000	97	
Low profile	ZE	Height 5mmL, low impedance, high ripple		●		●	6.3 ~ 35	1.0 ~ 100	2000	98	
	ZS	Height 7mmL, low impedance, high ripple		●		●	6.3 ~ 50	2.2 ~ 330	2000	99	
	ZL	Height 7mmL, low impedance, high ripple		●	●	●	6.3 ~ 50	2.2 ~ 330	3000	100	
	ZT	Height 7mmL, long life		●	●	●	6.3 ~ 50	2.2 ~ 330	5000	101	
Low impedance	WL	Extremely low impedance, miniaturized, wide voltage				●	6.3 ~ 500	1.0 ~ 15000	2000 ~ 5000	102	
	MD	Ultra low impedance, high ripple		●		●	6.3 ~ 16	470 ~ 3300	2000	105	
	RZ	Extremely low impedance, high reliability				●	6.3 ~ 63	1.0 ~ 15000	2000 ~ 5000	106	
	MK	Ultra low impedance, miniaturized, high ripple		●	●	●	6.3 ~ 100	1.0 ~ 15000	2000 ~ 5000	108	
	MZ	Ultra low impedance, miniaturized, high ripple		●	●	●	6.3 ~ 100	1.0 ~ 15000	2000 ~ 5000	111	
	KN	Ultra low impedance, high ripple		●	●	●	10 ~ 50	33 ~ 3300	2000 ~ 5000	113	
	RP	Extremely low impedance, long life				●	6.3 ~ 50	1.0 ~ 15000	4000 ~ 10000	115	
	WF	Extremely low impedance, miniaturized, long life		●	●	●	6.3 ~ 100	1.0 ~ 15000	5000 ~ 10000	117	
	LZ	Ultra low impedance, long life		●	●	●	6.3 ~ 50	10 ~ 8200	6000 ~ 10000	119	
	ML	Ultra low impedance, long life		●	●	●	6.3 ~ 100	10 ~ 10000	6000 ~ 10000	121	
	LQ	For LED lighting applications, ultra low imp., high ripple		●	●	●	6.3 ~ 120	27 ~ 8200	6000 ~ 10000	123	
	LN	For LED lighting applications, ultra low imp., high ripple		●	●	●	10 ~ 35	390 ~ 12000	10000	125	
	LY	For LED lighting applications, long life		●	●	●	10 ~ 100	1 ~ 330	10000	127	
	MH	Ultra low impedance, long life		●	●	●	6.3 ~ 50	10 ~ 10000	7000 ~ 12000	129	
	QY	For LED lighting applications, long life		●	●	●	35 ~ 50	22 ~ 560	13000	131	
	MG	For LED lighting applications, long life		●	●	●	10 ~ 35	100 ~ 4700	20000	132	
	PSU, SMPS, Adapter	KS	For PSU applications, high ripple, long life				●	420 ~ 500	47 ~ 150	8000	133
		SB	For PSU applications, high ripple, long life				●	420 ~ 500	47 ~ 150	10000	134
		KA	For PSU applications, high ripple current				●	400 ~ 500	3.3 ~ 150	3000	135
RH		For PSU applications, high ripple current				●	160 ~ 500	1.0 ~ 220	5000	137	
BH		For PSU applications, high ripple current				●	200 ~ 500	2.2 ~ 100	5000	139	
KU		For PSU applications, long life, high ripple current				●	400 ~ 500	1.0 ~ 150	5000	140	
BL		For PSU applications, long life				●	160 ~ 500	1.0 ~ 150	10000	142	
MT		For Display applications, high reliability				●	160 ~ 500	10 ~ 470	12000	144	
KJ		For PSU applications, extremely long life, high ripple current				●	160 ~ 500	1 ~ 470	12000	146	
BN		For Network applications, long life				●	400 ~ 500	47 ~ 180	12000	148	
MP		For Display applications, long life				●	160 ~ 500	10 ~ 470	12000 ~ 15000	149	
High temperature	MJ	For PSU applications, high ripple, long life				●	160 ~ 500	3.3 ~ 470	15000 ~ 20000	151	
	RB	High temp. range, for 125°C use, miniaturized		●		●	6.3 ~ 250	1.0 ~ 15000	1000 ~ 2000	153	
	WP	High temp. range, for 125°C use, long life		●	●	●	35 ~ 100	270 ~ 4700	5000	156	
	WT	High temp. range, for 125°C use, long life, low impedance		●	●	●	6.3 ~ 100	10 ~ 3300	2000 ~ 5000	158	
	LJ	For LED lighting applications, wide voltage, high temp. for 130°C use				●	10 ~ 400	1.0 ~ 4700	1000 ~ 4000	160	
	BK ☆	For PSU applications, high temp. for 125°C use				●	160 ~ 450	2.2 ~ 180	5000	162	
	BQ ★	High temp. range, for 125°C use, long life				●	450 ~ 500	22 ~ 100	5000	164	
	Special Applications	MW	High ripple current, long life				●	25 ~ 500	3.3 ~ 470	5000	165
LR ★		For airbag applications, high capacitance				●	25 ~ 35	2500 ~ 14000	5000	166	
VP		For LED lighting applications, high temp. for 135°C use				●	10 ~ 35	220 ~ 6800	3000	167	
VQ		High temp. range, for 150°C use, low impedance				●	10 ~ 100	33 ~ 5600	1000	169	
VX ★		High temp. range, for 150°C use, low impedance				●	50 ~ 100	68 ~ 1000	2000	171	
Non-polarize	NP	Standard	●			●	6.3 ~ 250	1.0 ~ 6000	2000	172	
	NS	Height 7mm		●		●	6.3 ~ 63	1.0 ~ 47	2000	174	
	NE	Height 5mm		●		●	6.3 ~ 50	1.0 ~ 47	1000	175	
	RN	Wide Temp. range				●	6.3 ~ 100	1.0 ~ 6800	1000	176	

# CONTENTS

## 5 Large Aluminum Electrolytic Capacitors

★ New series  
☆ Upgrade series

Series	Features	Operating Temperature Range(°C)	General	Miniature	Long life	Solvent Proof	Voltage Range (VDC)	Capacitance Range (μF)	Load Life Time (hours)	Page	
Snap-in Terminal	HC	Standard	-40(-25) ~ 85	●		●	6.3 ~ 550	47 ~ 100000	2000	183	
	HJ	Miniaturized	-40(-25) ~ 85		●	●	10 ~ 500	56 ~ 56000	3000	186	
	HF	Long life	-40(-25) ~ 85		●		160 ~ 450	56 ~ 3300	5000	189	
	JR	Long life	-25 ~ 85			●	400 ~ 450	56 ~ 680	10000	191	
	HE ☆	Wide temp.range, standard	-40(-25) ~ 105	●		●	6.3 ~ 600	47 ~ 68000	2000	192	
	JK	Wide temp.range, high ripple current	-40(-25) ~ 105	●			250 ~ 450	82 ~ 1500	2000	195	
	HK	Wide temp.range, miniaturized	-40(-25) ~ 105		●	●	6.3 ~ 500	68 ~ 68000	3000	196	
	HG	Wide temp.range, high ripple current	-40(-25) ~ 105		●		250 ~ 450	150 ~ 680	3000	199	
	KG	Wide temp. High ripple current	-40 ~ 105		●		400 ~ 500	100 ~ 560	3000	200	
	HH	Surge voltage	-25 ~ 105		●		450	68 ~ 560	3000	201	
	HL	Wide temp.range, miniaturized, long life	-40(-25) ~ 105		●	●	●	10 ~ 500	68 ~ 56000	5000	202
	JX ★	High voltage, long life	-25 ~ 105			●		550 ~ 600	120 ~ 390	5000	205
	HY	Wide temp. range, long life	-40(-25) ~ 105			●		160 ~ 500	68 ~ 1800	7000	206
	JY	Long life	-25 ~ 105			●		400 ~ 500	47 ~ 470	10000	208
	JZ	Long life	-25 ~ 105			●		10 ~ 450	33 ~ 33000	20000	209
HB	High temp. range, for 125°C use	-40(-25) ~ 125				●	10 ~ 450	100 ~ 15000	1000 ~ 3000	212	
LUG Terminal	LM	For general use	-40(-25) ~ 85	●		●	16 ~ 450	150 ~ 150000	2000	214	
Screw Terminal	GT	Standard	-40(-25) ~ 85	●			16 ~ 500	180 ~ 470000	2000	216	
	GY	High ripple	-25 ~ 85		●		450	2700 ~ 10000	2000	219	
	CU	WideTemp. range, standard	-40(-25) ~ 105	●			16 ~ 500	1000 ~ 470000	2000	220	
	GF	For inverter circuits, long life	-25 ~ 85			●	350 ~ 600	1000 ~ 12000	5000	223	
	GR	For inverter circuits, long life, high ripple	-25 ~ 85			●	400 ~ 450	1000 ~ 10000	5000	225	
	GL	High ripple, long life	-25 ~ 85			●	350 ~ 450	1500 ~ 12000	20000	227	
	EV	For inverter circuits, long life	-25 ~ 105			●	400 ~ 500	1000 ~ 6800	2000 ~ 5000	228	
	EY	For inverter circuits, long life	-25 ~ 105			●	350 ~ 450	1500 ~ 12000	7000	229	
Special Type	LW,SW	For welding machine	-25 ~ 85				315, 475	225 ~ 2200	-	230	
	AM	For audio equipment	-40 ~ 85				16 ~ 100	470 ~ 33000	2000	231	
	DF	For photo flash	-20 ~ 55				330, 360	200 ~ 1500	-	232	
	AL,AY	For inverter air-conditioning system	-40 ~ 85				450	330 ~ 820	5000(7000)	233	
	AZ	For inverter air-conditioning system	-40 ~ 85				450	330 ~ 820	7000	234	
	AK	For inverter air-conditioning system, high ripple current,long life	-40 ~ 105				450	470 ~ 820	3000	235	
	AQ ★	For inverter air-conditioning system, high ripple current,long life	-40 ~ 105				450	330 ~ 820	5000	236	

## PART NUMBER SYSTEM

### Part Number System

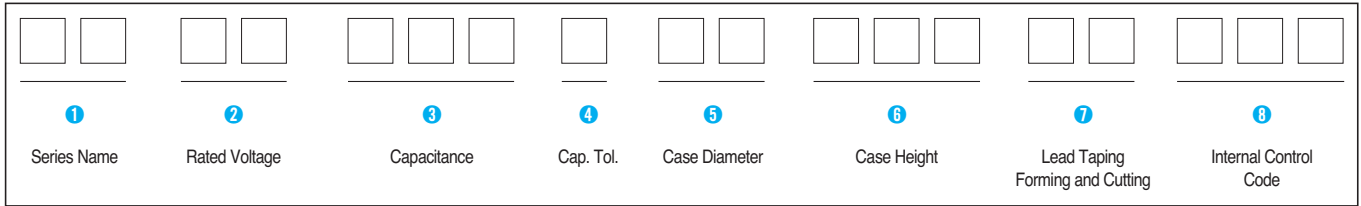

**1** Series Name  
See page 6

**2** Rated Working Voltage

<b>WV</b>	<b>2.5</b>	<b>4</b>	<b>6.3</b>	<b>10</b>	<b>16</b>	<b>20</b>	<b>25</b>
<b>Code</b>	0E	0G	0J	1A	1C	1D	1E
<b>WV</b>	<b>35</b>	<b>40</b>	<b>50</b>	<b>63</b>	<b>80</b>	<b>100</b>	<b>160</b>
<b>Code</b>	1V	1G	1H	1J	1K	2A	2C
<b>WV</b>	<b>200</b>	<b>250</b>	<b>315</b>	<b>350</b>	<b>400</b>	<b>450</b>	<b>500</b>
<b>Code</b>	2D	2E	2F	2V	2G	2W	2H

**3** Capacitance

ex) 4.7 $\mu$ F    475  
 47 $\mu$ F    476  
 470 $\mu$ F    477  
 4700 $\mu$ F    478  
 47000 $\mu$ F    479

**4** Capacitance Tolerance

<b>Tolerance (%)</b>	$\pm 10$	$\pm 20$	$\begin{matrix} -10 \\ +20 \end{matrix}$	$\begin{matrix} -10 \\ +30 \end{matrix}$	$\begin{matrix} -10 \\ +50 \end{matrix}$
<b>Code</b>	K	M	V	Q	T

**5** Case Diameter

ex)  $\varnothing 4$     04             $\varnothing 12.5$     12  
 $\varnothing 5$     05             $\varnothing 16$     16  
 $\varnothing 6.3$     6L             $\varnothing 18$     18  
 $\varnothing 8$     08             $\varnothing 22$     22  
 $\varnothing 10$     10

**6** Case Height

ex) 5mm    005    12.5mm    12M  
 7.5mm    07M    20mm    020  
 7.7mm    07K    13.5mm    13M  
 9.5mm    09M    25mm    025  
 11mm    011    31.5mm    31M  
 12mm    012    35.5mm    35M

**7** Lead Taping, Forming and Cutting

	Type	Code
<b>Chip</b>	Reel	VR
	Vibration Resistance Reel	VG
<b>Lead</b>	Bulk	BB



## LIST OF SUBSTITUTE FOR DISCONTINUED SERIES

- Production discontinuation of old series at Samwha is implemented as planned.
- Technical documents and samples are available upon the request to study alternative products.
- The following series are discontinued.
- Please use the recommended replacements in the table.

Type	Characteristics	Discontinued Series	Obsolete Year	Substitute Series	Page	
SMD	85°C Standard	MC	Year 2004	SC	58	
		GC				
	105°C Standard	TC	Year 2006	JH	61	
	105°C 3000 hours	JC	Year 2019	JM	63	
	105°C Impedance	CZ	Year 2019	CD	69	
CK		Year 2020				
	130°C Standard	CF	Year 2019	KC	79	
MINIATURE RADIAL LEAD	85°C Standard	SA	Year 1996	SD	89	
		GA				
		SG				
		SV				
		Height 7mm, high CV	SK	Year 1996	SS	91
	105°C Standard	RA	Year 1994	RD	93	
		RG	Year 2004			
		RV	Year 2006			
	Low Impedance Standard	RM	Year 2019	RZ	106	
		WD	Year 2006			
		WA	Year 2009			
	Low Impedance	LK	Year 2018	WL	102	
		RF	Year 2000			
	Extremely low Impedance, long life	RX	Year 2002	RP	115	
		RQ	Year 2006			
	Low Impedance Standard	MQ	Year 2019	MK	108	
		WB	Year 2009			MZ
	Ultra Low Impedance	WK				
		WH				
	Ultra Low Impedance	WN	Year 2009	ML	121	
	Ultra Low Impedance, high ripple	MN	Year 2018	KN	113	
		MB	Year 2019			
	For PSU applications, long life	SJ	Year 2018	KS	133	
	High Temp. range, for 130°C, low impedance	VA	Year 2018	VP	167	
	Long life	BG	Year 2015	BL	142	
		PF	Year 2019			
	For PSU 105°C high ripple, long life	BD	Year 2014	KU	140	
PQ		Year 2015				
RU						
125°C 2000 hours, standard	MU	Year 2018	BK	162		
	RW	Year 2006				
High Temp. range, for 155°C	VB	Year 2018	VQ	169		
	BM	Year 2019				
85°C 2000 hours non-polarized	BP	Year 2016	NP	172		
LARGE	85°C standard, snap-in	HS	Year 1994	HC	183	
		KL	Year 1996			
		HQ				
		HM	Year 1999			
	105°C standard, snap-in	HD	Year 1996	HE	192	
		HA	Year 1999			
	105°C 3000 hours, high ripple	HV	Year 2013	HK	196	
		JG	Year 2017			
	105°C 5000 hours	JF	Year 2020	HL	202	
	105°C snap-in, long life	HU	Year 2006	HY	206	
		SX	Year 1994			
	85°C standard, screw terminal	SM	Year 2006	GT	216	
		GK	Year 2017			
		GM	Year 2019			
	85°C 5000 hours, high ripple	GN	Year 2016	GF	223	
GH						
For photo flash	SF	Year 1996	DF	232		

## ■ Eco-friendly activity

### ● Background of Environment friendly Products

Eu declared RoHS law to restrict the using of six hazardous substances. (February, 2003) July 1, 2011 Announces recast RoHS Directive (2011/65 / EU) that restructured the existing RoHS Directive (2002/95 / EC).

Low	Contents	Enforcement Data
RoHS	Pb, Cd, Hg, Cr+6, PBBs, PBDEs	July 1, 2006. (2002/95/EC)
RoHS II	Pb, Cd, Hg, Cr+6, PBBs, PBDEs, DEHP, BBP, DBP, DIBP	January 3, 2013. (2011/65/EU)

\* RoHS : Restriction of Hazardous Substances

### ● Allowable criteria

substance	Regulation
1) Pb - Lead	Less than 1000 mg/kg
2) Cd - Cadmium	Less than 100 mg/kg
3) Hg - Mercury	Less than 1000 mg/kg
4) Cr(VI) - Hexavalent Chromium	Less than 1000 mg/kg
5) PBBs - Polybrominated biphenyls	Less than 1000 mg/kg
6) PBDEs - Polybrominated diphenyl ethers	Less than 1000 mg/kg
7) DEHP - Bis(2-ethylhexyl) phthalate	Less than 1000 mg/kg
8) BBP - Butyl benzyl phthalate	Less than 1000 mg/kg
9) DBP - Dibutyl phthalate	Less than 1000 mg/kg
10) DIBP - Diisobutyl phthalate	Less than 1000 mg/kg

\* Materials are not intentionally added and below limits by RoHS Directives

#### Label Marking

Packages containing products compliant with RoHS Directive are identified by the information "RoHS" (See sample label); these markings identify these products being fully compliant with the RoHS Directive

<b>RoHS</b>
-------------

### ● Other eco-friendly activities

Regulated substance	Related activities
REACH_SVHC	Complies with Regulation (EC) No 1907/2006.
Halogen-Free	Voluntary reduction of harmful substances
Conflict Minerals Reporting	It follows the standardization template created by EICC® and GeSI.

\* Samhwa Electric is leading the production of eco-friendly products through continuous monitoring of hazardous substances.

## Application Guidelines

Correct application and strict adherence to the important information listed below, will ensure optimum performance of the capacitors over their entire specified life.

### 1. POLARITY

If you should reverse the polarities of an aluminum electrolytic capacitor, it would lead to short-circuited circuitry and may further result in an explosion if the unit is kept energized. SAMWHA offers a unit of  $\varnothing 6.3$  or more with safety vent design as the standard type in order to prevent possible accidents that may take place if the unit should be connected with its polarities reversed.

It is advisable to use non-polar capacitors for a DC circuit where the polarity is to be reversed.

### 2. OVERVOLTAGE

Do not apply overvoltage. When overvoltage is applied to the capacitor, leakage current increases drastically, causing heat generation, short-circuit or breakage.

### 3. RIPPLE LOAD

The rated ripple current given for certain conditions (Temperature, Frequency) shall not be exceeded. If so, early failure may result.

The sum of DC-bias and maximum amplitude of ripple voltage shall be within rated voltage and 0V. Electrolytic capacitors are not normally designed for AC application.

### 4. TEMPERATURE RANGE

Use the electrolytic capacitors according to the specified operating temperature range. Applying capacitors surpassing guaranteed conditions may cause destruction due to rapid characteristic deterioration. Usage at room temperature will ensure longer life. (When using the capacitors under  $-45^{\circ}\text{C}$ , its life equals that using capacitors at  $-45^{\circ}\text{C}$ )

### 5. CHARGE/DISCHARGE

If used in circuits in which charge and discharge are frequently repeated, the capacitance value may drop, or the capacitor may be damaged. Please consult our technical department for assistance in these applications.

### 6. FOR SERIES CONNECTION

Aluminum electrolytic capacitors may be connected in series, but when doing so it should be noted that the voltage distribution will be according to their leakage currents. This phenomenon may induce irregularities in voltage load and cause maximum ratings to be exceeded, this could have drastic consequences especially with high voltage capacitors. Series connected electrolytic capacitors should therefore be supplied the voltages shall be proportionally distributed by balancing resistors.

전해 커패시터를 사용할 때 다음 사항에 주의하시기 바랍니다.

### 1. 극성

알루미늄 전해 커패시터의 극성을 역으로 사용하면 회로가 단락되거나 커패시터가 폭발할 수 있습니다. 극성이 역으로 사용될 경우 발생 가능한 사고를 방지하기 위하여  $\varnothing 6.3$  이상의 표준품은 방폭 구조를 갖도록 설계됩니다.

극성이 불분명하거나, 때때로 극성이 반전되는 DC 회로에는 무극성 전해 커패시터를 사용하십시오.

### 2. 과전압

과전압을 인가하지 마십시오.

과전압이 커패시터에 인가되면 누설전류가 급격히 증가하며, 이것은 발열이나 회로 단락의 원인이 됩니다.

### 3. 리플 부하

정해진 조건(온도, 주파수)에 맞는 정격 리플전류를 초과하지 마십시오. 정격치 이상의 리플전류가 커패시터에 흐르게 되면 초기 고장이 발생할 수 있습니다.

직류 바이어스 전압과 리플전압의 합은 0V에서부터 정격전압 이내이어야 합니다.

전해 커패시터는 AC 응용을 할 수 없습니다.

### 4. 온도 범위

알루미늄 전해 커패시터는 정격사용온도범위 내에서 사용해야 합니다. 보증 범위를 초과하는 조건에서의 사용은 급격한 특성 열화가 발생되어 파손되는 경우가 있습니다. 상온에서 사용하면 수명을 연장시키는 효과를 얻을 수 있습니다. ( $-45^{\circ}\text{C}$  이하에서 커패시터를 사용시,  $-45^{\circ}\text{C}$ 와 동일한 수명을 지니게 됩니다.)

### 5. 충방전

충방전이 계속 반복되는 회로에 사용하면 정전용량이 감소하고 커패시터가 폭발될 수 있습니다. 이러한 회로에 제품을 적용시킬 경우 저희 회사 기술연구소로 연락 바랍니다.

### 6. 직렬 연결

알루미늄 전해 커패시터는 직렬로 연결하여 사용할 수 있습니다. 그러나 직렬 연결 사용시 누설전류에 의한 전압의 배분에 주의하시기 바랍니다. 누설전류에 의한 전압의 배분은 불규칙한 부하전압을 유발할 수 있으며, 정격전압의 최고치를 초과할 수도 있습니다. 직렬로 연결된 커패시터에는 전위차조정저항(balancing resistor)으로 적절히 배분된 전압을 인가하십시오.

## 7. FOR PARALLEL CONNECTION

When you install more than 2 capacitors in parallel, consider the balance of current flowing into the capacitors.

## 8. MOUNTING

The distance between the terminal holes on the circuit board should be the same as that between the lead wires or terminals of the capacitor. Excessive force in mounting on circuit boards should be avoided.

Improper insertion of the lead wires in circuit board may cause electrolyte leakage, break the lead wires or impair their connection with the internal elements.

When the distance between the two terminal holes on the circuit board cannot be reduced to that between the lead wires, lead formed capacitors are recommended.

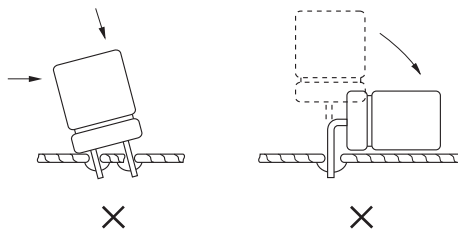

The main chemical solution of the electrolyte and the separator paper used in the capacitors are combustible. The electrolyte is conductive. When it comes in contact with the PC board, there is a possibility of pattern corrosion or short circuit between the circuit pattern which could result in smoking or catching fire. Do not locate any circuit pattern beneath the capacitor end seal.

In order to prevent possible damage by vibration on the circuit board, kindly bond our capacitors on the circuit board or use any fastening devices.

RADIAL TYPE	over Ø18 or 30mmL
SNAP-IN TYPE	over Ø22 or 40mmL

There should not be any circuit pattern or circuit wire above the capacitor safety vent.

Unless otherwise specified, following space should be made above the capacitor safety vent.

Case diameter	Ø6.3 ~ Ø16	Ø18 ~ Ø35	Ø40 ~
Space	2mm min.	3mm min.	5mm min.

If the capacitor safety vent is placed toward circuit board, the hole should be made to match the capacitor vent position.

## 7. 병렬 연결

두 개 이상의 커패시터를 병렬로 연결할 때 커패시터에 흐르는 전류의 배분을 고려하여 주십시오.

## 8. 기판 장착

회로기판에서 단자 홀(hole) 간격은 커패시터의 리드선이나 단자간의 간격과 같아야 합니다.

회로기판에 장착시 무리한 힘을 가하지 마십시오.

회로기판에 리드선을 무리하게 삽입할 경우 전해액의 누설, 리드선의 손상, 내부 요소와의 접촉부위의 파손 등이 발생할 수 있습니다.

회로기판의 홀(hole) 간격과 리드선의 간격이 맞지 않을 때에는 리드선이 가공된 커패시터를 사용하십시오.

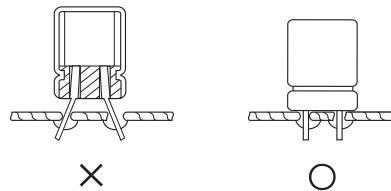

커패시터에 사용된 전해액의 주 용매와 전해지는 가연성이며 전해액은 전도성 재질입니다.

회로기판에 전해액이 묻을 경우 패턴이 부식되거나 회로 패턴 사이에 쇼트되어 발화될 수도 있으므로 커패시터 봉입구 밑에는 어떠한 회로 패턴도 설치하지 말아주십시오.

진동으로 문제시되는 회로기판에 장착하는 경우에는 반드시 기판과 제품 바닥면을 접착시키거나 별도의 고정 장치를 사용하십시오.

RADIAL TYPE	Ø18, L치수 30mmL 이상 제품
SNAP-IN TYPE	Ø22, L치수 40mmL 이상 제품

커패시터의 안전 변 위에 회로 패턴이나 배선이 없도록 하여 주십시오.

만약 그렇지 못하면 다음과 같이 안전 변이 작동할 수 있는 공간이 있어야 합니다.

Case diameter	Ø6.3 ~ Ø16	Ø18 ~ Ø35	Ø40 ~
Space	2mm 이상	3mm 이상	5mm 이상

만약 커패시터의 안전 변이 회로 기판으로 향한다면, 커패시터 안전 변 위치의 기판에 구멍을 설치해야 합니다.



# ALUMINUM ELECTROLYTIC CAPACITORS

Do not install screw terminal capacitor with end seal side down. When you install a screw terminal capacitor in a horizontal mount, the positive terminal must be in the upper position.

Screw 단자형 커패시터의 봉입구를 아래로 향하게 하지 말아 주십시오. 제품을 옆으로 눕혀 사용할 경우에는 양극 단자를 위로 향하도록 하여 주십시오.

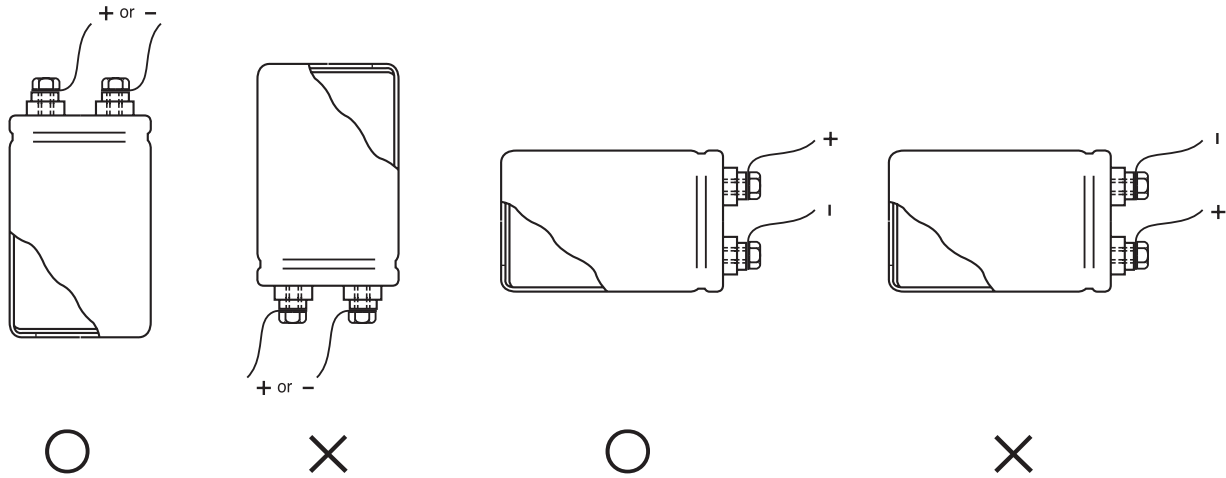

## 9. LEAD STRESS

Do not apply excessive force to the lead wires or terminals. If excessive force is applied to the lead wires and/or terminals, they may break and cause an open circuit. After mounting, avoid holding or applying force to the capacitor. Do not twist or carry the PC board by grasping the capacitor body after the capacitor are soldered to the PC board.

## 9. 리드 스트레스

커패시터의 리드선이나 단자에 무리한 힘을 가하지 마십시오. 리드선이나 단자의 단선 및 회로의 개방을 초래할 수 있습니다. 기판 장착 후에도 커패시터에 무리한 힘을 가하지 마십시오. 회로기판에 장착 후 커패시터를 잡고 이동하거나 비틀지 마십시오.

## 10. SOLDERING

In the dip soldering process of PC board with aluminum electrolytic capacitors mounted, secondary shrinking or crack of the sleeve may be observed when solder temperature is too high and/or dipping time is too long.

If the lead wire of other components or pattern of bothsided PC board is close to the capacitor terminal the similar failure may be also originated.

## 10. 납땜

알루미늄 전해 커패시터가 장착된 인쇄회로기판의 침적납땜 공정에서 납땜 온도가 너무 높거나, 지나치게 오랫동안 침적할 경우 슬리브의 2차 수축이나 갈라짐이 발생할 수 있습니다. 양면 인쇄회로기판의 패턴이나 다른 부품의 리드선과 커패시터의 단자가 아주 근접할 경우에도 위와 같은 슬리브의 이상이 발생할 수 있습니다.

Please avoid having flux adhere to any portion except the terminal. Solder iron does not touch any portion of capacitor body.

단자이외의 부분에 플럭스가 묻지 않도록 하여 주시고 커패시터에 납땜 인두가 닿지 않도록 하여 주십시오.

## 11. Cleaning, Mounting of the PCB after soldering

1)When you clean a PCB, halogen cleaning agents can cause corrosion of aluminum foil and lead tab. If you need to clean, please replace Isopropyl Alcohol(IPA), Water as halogenated cleaning agents.

2)5minutes either by ultrasonic, vapor or immersion cleaning method.(chip type :2minutes) Becareful not to apply mechanical stress to the terminals or lead wires

## 11. 납땜 후 회로기판 세정

1)인쇄회로기판 세정시 할로겐계의 세정제가 커패시터의 내부에 침투하게 되면 알루미늄 호일과 리드에 부식의 원인이 될 수 있습니다. 세척이 필요한 경우에는 할로겐계 세정제 대신 이소프로필 알콜이나 물을 사용하십시오.

2)세정조건은 초음파, 증기, 침적 등의 세척 방법에 대하여 5분(단 chip type은 2분) 단자나 리드선에 기계적인 힘이 가해지지 않도록 주의 하십시오.

3) Common type of halogenated cleaning agents are listed below

Chemical Name	Structural Formula	Representative Brand Name
Trichlorotrifluoroethane	C <sub>2</sub> Cl <sub>3</sub> F <sub>3</sub>	Freon TF, Daiflon S-3
Fluorotrichloromethane	CCl <sub>3</sub> F	Freon-11, Daiflon S-1
1,1,1-Trichloroethane	C <sub>2</sub> H <sub>3</sub> Cl <sub>3</sub>	Chloroethene
Trichloroethylene	C <sub>2</sub> HCl <sub>3</sub>	Trichlene
Methyl Chloride	CH <sub>3</sub> Cl	MC

Don't use the solvents listed above as cleaning solvent agents even for solvents proof capacitors, because it has strong chemical reaction.

4) When using a latex-based adhesive on the capacitor's rubber end seal for adhesion to a PCB, corrosion may occur depending on the kind of solvent in the adhesive. Select an adhesive as an organic solvent with dissolved polymer that is not halogenated hydrocarbon.

5) Penetration Channel of Solvent and Corrosion Mechanism

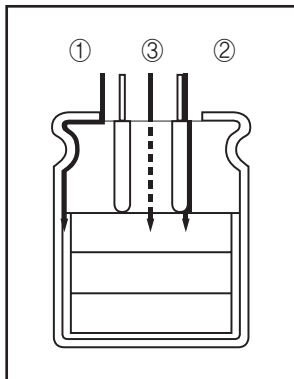

- ① Penetration between the rubber and the aluminum case
  - ② Penetration between the rubber and the lead wires
  - ③ Penetration through the rubber
- Cl-gotten inside a capacitor reacts with aluminum.  
 $Al + 3Cl^- \rightarrow AlCl_3 + 3e^-$   
 Then, AlCl<sub>3</sub> resolves in water  
 $AlCl_3 + 3H_2O \rightarrow Al(OH)_3 + 3H^+ + 3Cl^-$   
 Thus, the Cl<sup>-</sup> ion is freed again and repeats the corrosion of aluminum.

3) 할로겐계의 세정제의 일반적 유형은 아래의 표와 같다.

화학명	구조식	대표 상품명
Trichlorotrifluoroethane	C <sub>2</sub> Cl <sub>3</sub> F <sub>3</sub>	Freon TF, Daiflon S-3
Fluorotrichloromethane	CCl <sub>3</sub> F	Freon-11, Daiflon S-1
1,1,1-Trichloroethane	C <sub>2</sub> H <sub>3</sub> Cl <sub>3</sub>	Chloroethene
Trichloroethylene	C <sub>2</sub> HCl <sub>3</sub>	Trichlene
Methyl Chloride	CH <sub>3</sub> Cl	MC

위의 표에 열거한 물질들은 반응성이 매우 강하므로 내세척용 커패시터의 경우에도 세정제로 사용해서 안됩니다.

4) 커패시터의 밀폐용 고무에 고무계의 접착제를 사용하여 인쇄 회로 기판에 접착할 경우, 접착제의 종류에 따라 커패시터의 부식이 발생할 수 있습니다. 접착제로서는 할로겐화되지 않는 유용성 폴리머로 구성된 유기용제를 선택하십시오. 코팅(coating)을 행할 경우 제품과 기판간에 세정액이 남지 않도록 세정 직후 50~80°C에서 열풍 건조하여 주시기 바랍니다.

5) 용제의 침투경로 및 반응 메커니즘

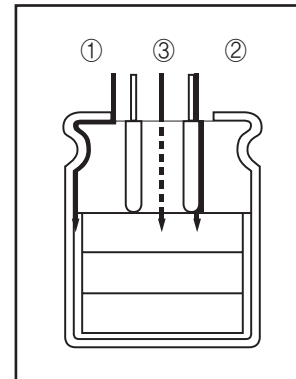

- ① 밀폐용 고무와 알루미늄 케이스 사이로 침투
  - ② 밀폐용 고무와 리드선 사이로 침투
  - ③ 밀폐용 고무를 통과하여 침투
- 커패시터의 내부로 침투한 염소 이온은 아래와 같이 알루미늄과 반응을 한다.  
 $Al + 3Cl^- \rightarrow AlCl_3 + 3e^-$   
 이때 AlCl<sub>3</sub>는 물에 녹아 아래와 같이 된다.  
 $AlCl_3 + 3H_2O \rightarrow Al(OH)_3 + 3H^+ + 3Cl^-$   
 그래서 염소이온(Cl<sup>-</sup>)은 다시 자유전자가 되어 알루미늄을 부식시킨다.

## 12. Adhesive and Coating Materials

Do not use halogenated adhesives and coating materials to fix Aluminum Electrolytic Capacitors.

Flux between the surface of capacitors should be cleaned before using adhesives or coating materials. Solvents should be dried up before using adhesives or coating materials. Do not cover up all the sealing area of capacitors with adhesives or coating materials. Make coverage only partial. (The sealing area 30%)

## 13. INSULATION MATERIAL

### Sleeve material

The standard sleeve material is P.V.C or P.E.T if exposed to xylene, toluene, etc. and then subjected to high heat, the sleeve may crack.

### Case and cathode terminal

The case of capacitor is not insulated from the cathode terminal.

### Dummy terminals for snap-in type

Dummy terminals are not insulated from the element.

Dummy terminals are for added stability only, and should never be electrically connected to either the positive or negative terminal.

## 14. STORAGE

Do not store the capacitors in high temperature and high humidity conditions. Avoid direct sunlight.

(Recommendable conditions : 5 to 35°C, 75% or below RH)

Store the capacitors in the package.

Capacitors should not be direct contact with water, brine or oil. Capacitors must not be exposed to toxic gases such as hydrogen sulfide, sulfurous acid, nitrous acid, chlorine, or ammonium.

Capacitors should be stored sealed in bag until they are actually used.

Once the sealed bag is cut open, all the parts should be used at one time. If not, then the remaining parts should be placed in a bag and sealed with tape.

In order to maintain a good solderability of the parts, shelf life of parts should not exceed 1 year.

When the capacitor is stored for a long time without applying voltage, leakage current tends to increase, due to deterioration of aluminum oxide film. This returns to normal by applying voltage. Apply voltage (Aging) before use if the capacitor is stored long time.

It is recommended to apply DC working voltage to the capacitor for 30 minutes through 1kΩ of protective series resistor.

## 12. 제품 고정제와 코팅

할로겐계 용제를 포함하는 고정제, 코팅제는 사용하지 말아 주십시오. 고정제, 코팅제를 사용하기 전에 기판과 콘덴서 봉구부 부분에 플럭스가 남거나 오염된 채로 놓아두지 말아 주십시오.

기판 세척제는 고정제, 코팅제를 사용할 때 콘덴서 봉구부 전체를 밀봉시키지 말아 주십시오. (봉구부의 30% 이하)

## 13. 절연

### 슬리브 재질

표준 슬리브의 재질은 P.V.C 또는 P.E.T이며, 크실렌이나 톨루엔에 노출되거나, 커패시터가 고온의 환경에서 사용된다면 슬리브가 갈라질 수 있습니다.

### 케이스와 음극단자

커패시터의 케이스와 음극단자는 절연이 되지 않습니다.

### SNAP-IN 단자형 제품의 보조단자

보조단자는 내부요소와 절연이 되지 않습니다.

보조단자는 커패시터를 견고하게 고정시키기 위한 것이므로 양극단자나 음극단자와 전기적인 연결이 없어야 합니다.

## 14. 보관

커패시터를 고온, 다습 또는 직사광선의 환경에서 저장하지 마십시오.

(적정 조건 : 5~35°C, 75% 이하의 상대습도)

커패시터를 포장된 상태로 보관하여 주십시오. 커패시터에 물, 소금물 또는 기름이 직접 닿지 않도록 주의하여 주십시오.

커패시터를 유화수소, 아황산, 질산 염소, 암모늄 등의 유해한 가스에 노출된 환경에서 보관하지 말아 주십시오.

커패시터를 실제 사용하기 전까지 밀봉된 Bag에 넣어 보관하세요. 밀봉된 포장을 뜯은 후 모든 부품을 즉시 사용하세요. 전부 사용하지 않는다면, 남은 부품은 Bag에 넣어 테이프로 밀봉해 보관하세요.

부품들의 수명과 우수한 납땀성을 유지하기 위해서는 방치 후 1년을 초과하지 않아야 합니다.

전압을 인가하지 않은 상태에서 장기간 보관된 커패시터는 누설 전류가 증가하는 경향이 있습니다.

그러나 커패시터에 전압을 인가하면 정상으로 환원됩니다. 장기간 보관되었던 커패시터는 전압처리 후 사용하여 주십시오.

전압처리는 1kΩ의 보호저항을 통해 직류 정격전압을 30분 동안 인가해야 합니다.

## 15. EMERGENCY ACTION

When the safety vent is Open and some gas blows out from the capacitor, please turn the main switch of the equipment off or pull out the plug the power outlet immediately.

During vent operation, extremely hot gas(over 100°C) and electrolyte may blow out from the capacitors. Do not stand close to the capacitors. In case of eye contact, flush the poen eyes with large amout or clean water immediately, do not swallow. do not touch electrylte but wash skin with soap and water in case of skin contact.

## 16. DESTRUCTING CAPACITORS & OTHERS

In case of destructing our capacitors, Burn capacitors up after making holeson them or scrapping. When you try to destroy them by fire, you may expect explosion in the capacitors.

In order to prevent hazardous gas like chlorine gas, burn our capacitors on high temperature range. Burning sleeve on low temperature may cause producing chlorine gas.

When you do not have burning facilities, please contact special industrial wastes processing companies.

Capacitors may accumulate charge maturally during long storage time. In this case, the capacitors should be subject to voltage treatment through about 1kΩ resistor before use.

since it has possibilities for electric shock or burns, kindly, discharge it at the level of 1kΩ in advance.(sufficient and safe resistance values should be considered before applying)

For methods of testing, refer to KS C IEC 60384-4 (JIS C 5101-1, JIS C 5101-4)

Capacitors case size and other product standards specified in this catalog may be changed or modified without notice for improvement of quality.

## 15. 응급 조치

커패시터 사용 중 커패시터 안전 변이 열려 Gas가 분출될 경우 SET 의 전원 장치의 스위치를 끄거나 플러그를 즉시 뽑아 주십시오.

커패시터의 안전변 동작시 +100°C를 초과하는 Gas 분출 및 전해액 이 흘러 내릴 수 있으므로 가까이 다가가지 마십시오. 분출한 Gas가 눈에 들어가거나 흡입한 경우에는 즉시 물로 눈을 씻거나 삼키지 말고 입안을 닦아주시기 바랍니다. 전해액은 만지지 말고 만약 피부에 묻었을 경우 물이나 비누로 닦아 주십시오.

## 16. 커패시터 폐기 및 기타

커패시터를 폐기할 경우에는 구멍을 내거나 충분히 부순 후에 소각하여 주십시오. 소각시 커패시터가 폭발하는 경우도 있습니다.

커패시터는 외장 슬리브(PET)가 씌어져 있기 때문에 고온 소각을 하여 주십시오. 저온 소각을 하면 염소 Gas 등의 유해 Gas가 발생하는 원인이 됩니다.

커패시터를 소각하지 않은 경우에는 전문 산업폐기물 처리업체에 의뢰하여 주십시오.

커패시터는 재기 전압이 발생할 경우가 있습니다. 이런 경우에는 사용 전에 약 1kΩ의 저항을 통해 방전 처리 후 사용하여 주십시오.

감전 및 화상의 우려가 있으므로 사용전에 1kΩ(전압, 용량에 따라 충분히 여유를 고려한 저항 선택)의 저항을 통해서 방전처리를 해 주십시오.

기타 시험규격에 대해서는 KS C IEC 60384-4 (JIS C 5101-1, JIS C 5101-4)를 참조 바랍니다.

카다로그에 규정된 제품 사이즈 및 제품 기준은 품질 개선의 필요 성으로 인하여 귀사에 통지없이 변경될 수 있습니다.



## General introduction

### Rated capacitance

The capacitance value for which the capacitor has been designed and which is usually indicated upon it.

### Tolerance on rated capacitance

Preferred values of tolerance on rated capacitance are:  
 -20/+20%, -10/+20%, -10/+30%, -10/+50%, -10/+10%

### Rated voltage

The maximum direct voltage, or peak value of pulse voltage which may be applied continuously to a capacitor at any temperature within operating temperature range.

### Ripple voltage

An alternating voltage may be applied, provided that the peak voltage resulting from the alternating voltage, when superimposed on the direct voltage, does not exceed the value of rated voltage or fall under 0V and that the ripple current is not exceeded.

### Surge voltage

The maximum instantaneous voltage which may be applied to the terminations of the capacitor for a specified time at any temperature with the operating temperature range.

<b>Rated voltage (VDC)</b>	4	6.3	10	16	25	35
<b>Surge voltage (VDC)</b>	5	8	13	20	32	44

<b>Rated voltage (VDC)</b>	40	50	63	80	100	160
<b>Surge voltage (VDC)</b>	50	63	79	100	125	200

<b>Rated voltage (VDC)</b>	200	250	275	315	350	375
<b>Surge voltage (VDC)</b>	250	300	316	365	400	425

<b>Rated voltage (VDC)</b>	400	420	450	500	550	600
<b>Surge voltage (VDC)</b>	450	470	500	550	600	650

### Equivalent series resistance (ESR)

The ESR of an equivalent circuit having capacitance, inductance and resistance in series measured with alternating current of approximately sinusoidal waveform at a specified frequency.

$$ESR = \frac{\tan\delta}{2\pi fC}$$

where,

f = measurement frequency (120Hz)  
 C = measurement capacitance (F)

### Dissipation factor (tanδ)

The power loss of the capacitor divided by the reactive power of the capacitor at a sinusoidal voltage of specified frequency.

### Leakage current

Leakage current flows through a capacitor when DC voltage is applied in correct polarity. It is dependent on voltage, temperature and time.

### Ripple current

Any pulsating voltage (or ripple voltage superimposed on DC bias) across a capacitor results in an alternating current through the capacitor. Because of ohmic and dielectric losses in the capacitor, this alternating current produced an increase of temperature in the capacitor cell. The capacitor should be used within specified permissible ripple current in each standard products table.

In other condition of ambient temperature and frequency, ripple current multiplied by following multiplier can be applied as maximum permissible ripple current.

## Failure rate

The failure rate of an aluminum electrolytic capacitor follows a bathtub curve.

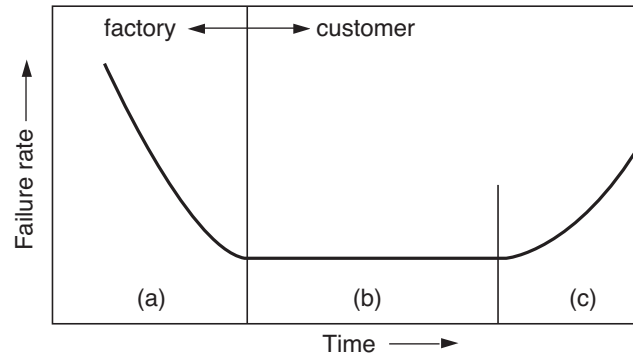

- (a) initial failure period (infant mortality)
- (b) random failure period (useful life period)
- (c) wear-out failure period

## Expected life - (\*for reference)

Temperature, humidity, ripple current and atmospheric pressure etc. have influence on the life of aluminum electrolytic capacitors. Among them, temperature has the greatest effect on life of capacitors. The relationship between ambient temperature and life of capacitor can be explained to so-called ARRHENIUS equation, generally the life of capacitor is reduced approximately by one-half for each temperature increase of 10°C. The life acceleration equation computes as shown below.

$$L = L_s \times 2^{\frac{T_s - (T + \Delta T)}{10}}$$

L : Lifetime of capacitor to be estimated (Hour)  
 L<sub>s</sub> : Base life time of capacitor (Hour)  
 T<sub>s</sub> : Maximum operating temperature shown in catalog (°C)  
 T : Ambient temperature (°C)  
 ΔT : An increase temperature produced by internal heating due to actual operating ripple current. (°C)

## Expected life chart - (\*for reference)

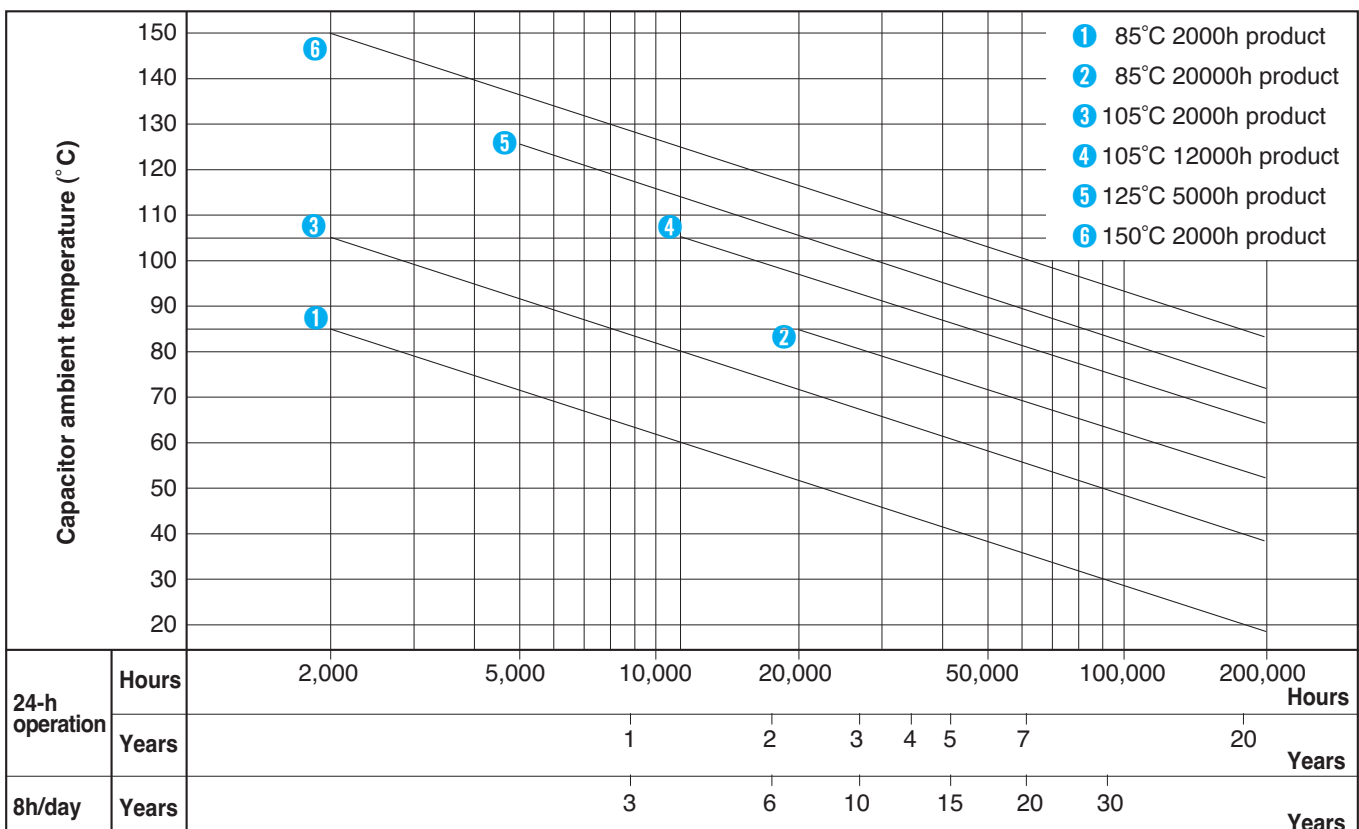

# Reflow soldering method for the chip aluminum electrolytic capacitor

## 1. Recommended conditions for reflow soldering

The chip aluminum electrolytic capacitor is subjected to soldering by reflow method.

Temperature and time conditions of reflow soldering shall be set as per each temperature profile shown below as a standard. The following are recommended conditions in the case of reflow soldering method for the chip aluminum electrolytic capacitor.

- (1) The capacitor shall not be subjected to either flow or dip soldering method.
- (2) Avoid soldering twice by reflow. The number of reflow time for chip aluminum electrolytic capacitor shall be once basically. If this type of capacitor has to be inevitably subjected to the reflow twice, enough cooling time between the first and the second reflow (at least more than 30 minutes) shall be taken to avoid the consecutive reflows by all means.
- (3) The touch up work with a soldering iron is allowed after the reflow soldering (Temperature of soldering iron : MAX 400°C, Time : 5 sec.), provided that carefully attention shall be paid lest a soldering iron should directly touch the capacitor body or its resin bottom base.

## 2. RECOMMENDED REFLOW SOLDERING CONDITIONS

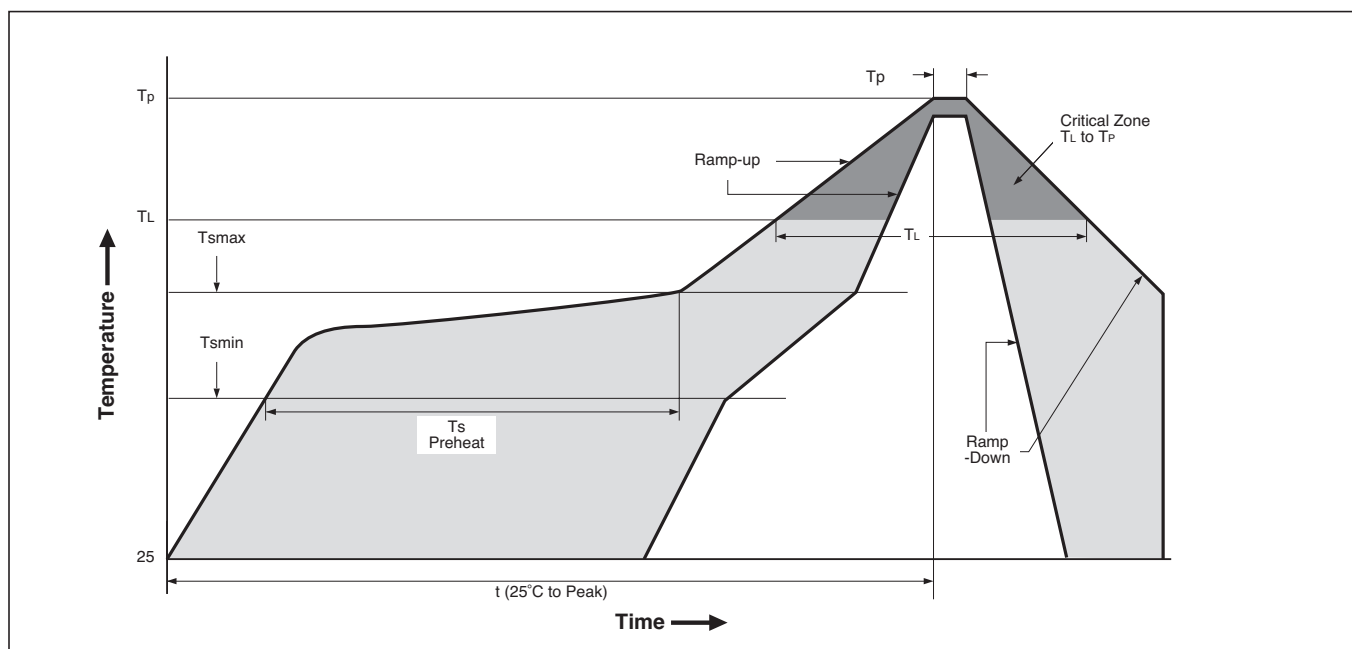

Profile Feature	Soldering condition	
	ø4 ~ ø10	ø12.5
Average Ramp-up Rate (TL to Tp)	3°C / second max.	3°C / second max.
Preheat	Temperature Min. (Ts min)	150°C
	Temperature Max. (Ts max)	200°C
	Time (Ts min to Ts max)	60 ~ 150 seconds
Ts max to TL -Ramp-up Rate	3°C / second max.	3°C / second max.
Time maintained above	Temperature (TL)	217°C
	Time (tL)	60 ~ 90 seconds
Peak/classification Temperature (Tp)	250°C	240°C
Time within 5°C of actual peak temperature (Tp)	10 seconds max.	10 seconds max.
Ramp-Down rate	3°C / second max.	3°C / second max.
Time 25°C to peak temperature	8 minute max.	8 minute max.

# 1

## Green-Cap(ELECTRIC DOUBLE LAYER CAPACITORS)

---

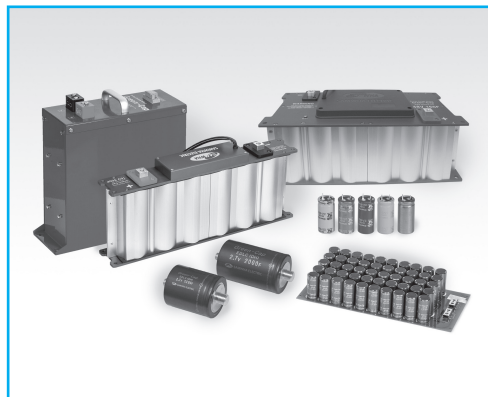



# Green-Cap (ELECTRIC DOUBLE LAYER CAPACITORS)

Electric double layer capacitor(EDLC) is a next-generation energy storage device. In recent years, there has been much exploration of new uses for EDLC, and it is expected that they will become even more commonly used in the future.

## What is electrical double layer capacitor (EDLC)?

A conventional capacitors have a dielectric sandwiched between two opposing electrodes. An aluminum electrolytic capacitor, as an example, uses an aluminum oxide film as a dielectric. However, EDLC does not have a dielectric. EDLC uses the electric double layer to function as the dielectric of activated carbon, therefore EDLC does not use a chemical reaction such as a redox reaction but rather store electricity by means of the physical adsorption of ions to the large specific surface area of activated carbon. EDLC consists of environmentally friendly active carbon and an organic solvent, whereas a conventional battery is made from heavy metals such as lead. EDLC does not harm the environment.

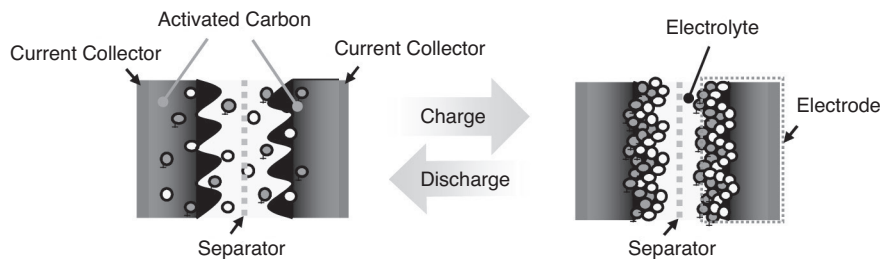

Electric Double Layer Capacitor Principle

## Product Features

- ▷ Stable charge and discharge cycle
  - Life is not affected by charging/discharging cycles because there is no chemical reaction
- ▷ The advantages of EDLCs over rechargeable batteries
  - Very safe, No risk of explosion or ignition
  - Environmentally-friendly, with no heavy metals used
  - Rapid charging and discharging (at heavy current )
  - Long cycle life, charging / discharging tens of thousands of times
  - Wide range of temperatures, operation even at low temperatures
  - Recycling is unnecessary (required for batteries)
- ▷ Character of Energy Storage Device

Section		EDLC	Ni-MH	LiB
Voltage (Operating Range)		2.7 (2.7 ~ 0)	1.2 (1.4 ~ 0.9)	3.7 (4.2 ~ 3.0)
Operating Temperature Range		-40 ~ 65°C	Charge : 0 ~ 45°C	Charge : 0 ~ 45°C
High Temperature Spec.	Test Condition	Max. Operating Temp. and Max. Operating Voltage	Cycle life by Temperature	Max. Operating Temp. and Max. Operating Voltage
	Guarantee	1500hrs	0 ~ 20°C: 500 cycle	168hrs
Electrolyte	Solvent	AC / PC	KOH	EC
	Salt	Salt		LiPF6
Dangerous		None	Corrosiveness	Firing, Explosion
Eco - friendly		Very good	Good	Bad

## Technical Data

● CHART 1

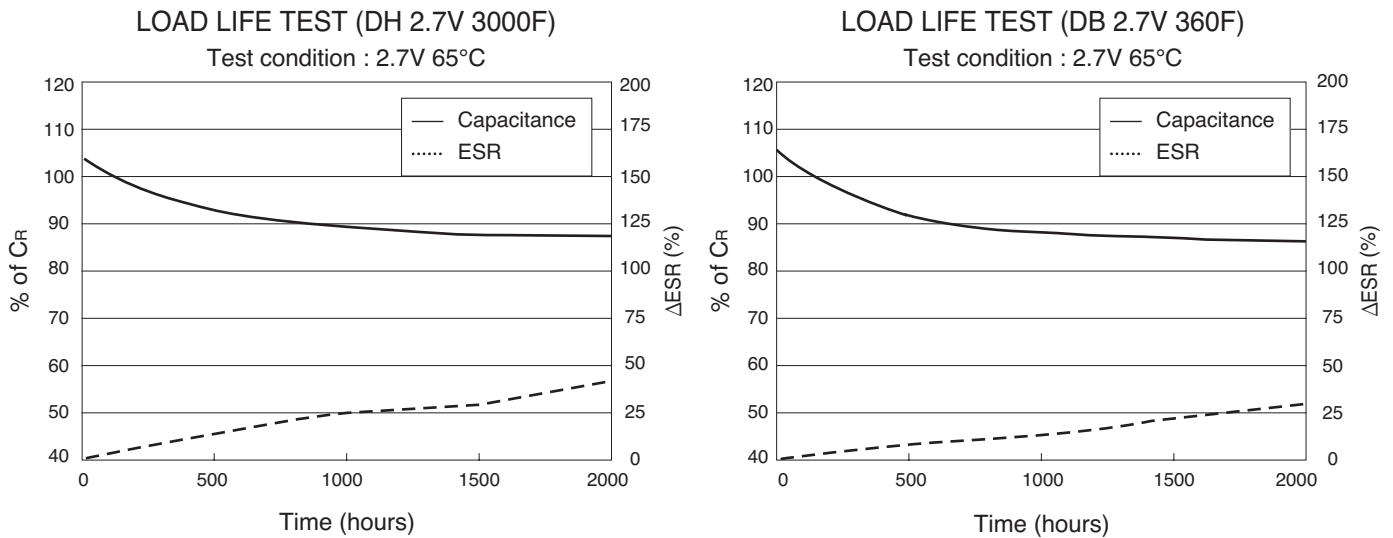

● CHART 2

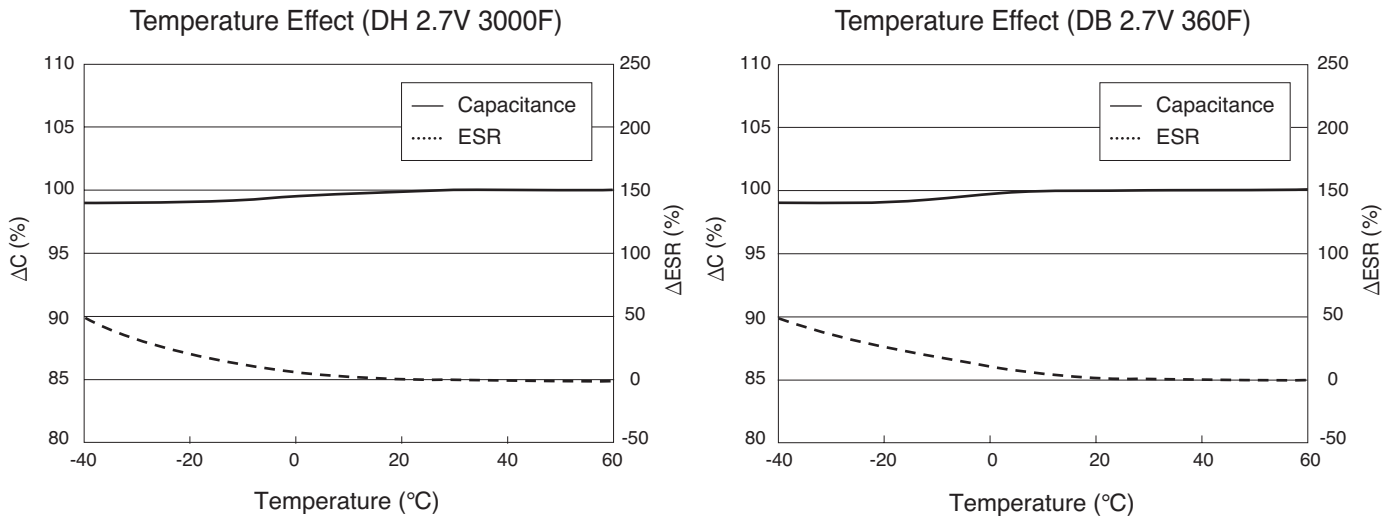

● CHART 3

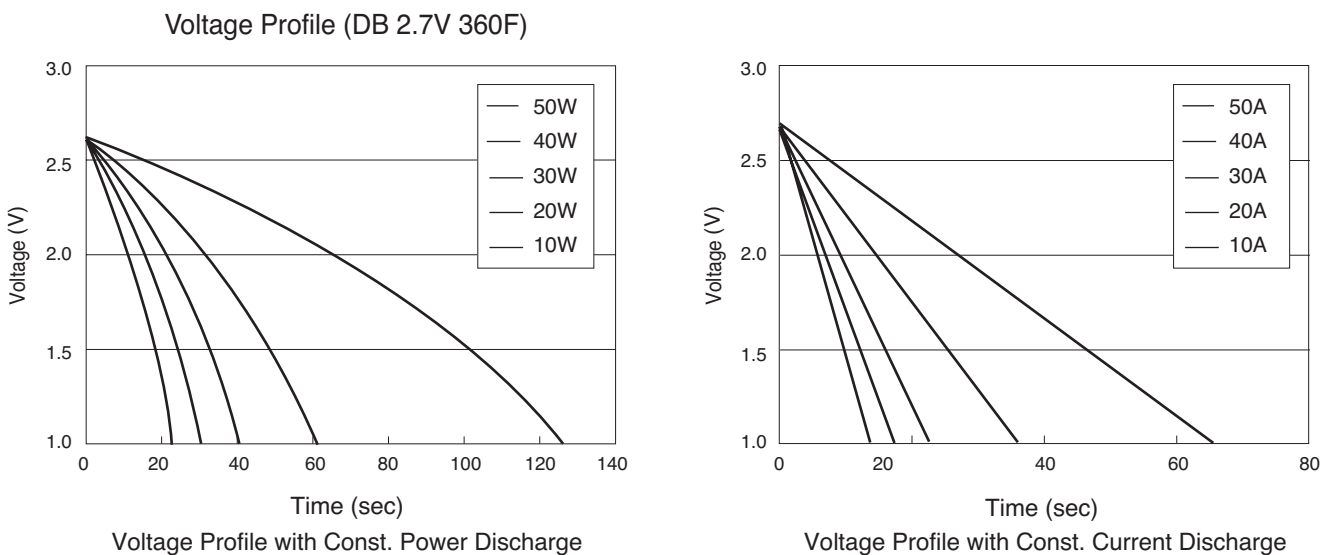

## Application Guidelines

### 1. Polarity

Be sure verify the polarity of the capacitor before use. If a reverse voltage is applied for a long time, capacitor lifetime is shortened and serious damage such as electrolyte leakage may occur.

Further more,there may be leftover electric charge from capacitor testing that could damage other circuit components such as the low-withstanding voltage parts of semiconductors, etc.

### 2. Voltage

If a Green-Cap is used at a voltage exceeding its rated voltage, not only is its life shortened, but depending on the actual voltage, gas generated by electrochemical reactions inside the capacitor may cause it to leak or rupture

### 3. Ambient Temperature

(1) Capacitor life is affected by operating temperature. In general, lowering ambient temperature by 10°C will double the life of a capacitor. Use the capacitor at the lowest possible temperature under the maximum guaranteed temperature.

(2) Operation above the maximum specified temperature not only shortens capacitor life, but can also cause serious damage such as electrolyte leakage.

Verify the operating temperature of the capacitor by taking into consideration not only the ambient temperature and temperature inside the unit, but also the radiation from heat generating elements inside the unit (power transistors, IC's, resistors, etc.) and self-heating due to ripple current.

Be careful not to place heat-generating elements across from the capacitor on the opposite of the PCB.

### 4. Ripple Current

Green-Cap has a higher internal resistance than do electrolytic capacitors and are more susceptible to internal heat generation when exposed to ripple current. When the temperature of the element rises, a reacting current flows inside the Green-Cap, generating reaction products and raising internal resistance even further. This makes it difficult to maintain capacitance. Set the allowable limit for the ripple current-induced rise in capacitor temperature to 3°C measured at the surface of the capacitor

### 5. Heat Stress During Soldering

Excessive heat stress may result in the deterioration of the electrical characteristics of the capacitor, loss of air-tightness, and electrolyte leakage due to the rise in internal pressure

(1) If the tip of the soldering iron touches the capacitor's external sleeve, the sleeve will melt or break.

(2) Use the general reference chart bellow to set soldering temperature and time.

(3) When soldering with a soldering iron, do not touch the tip to the body of the capacitor.

Minimize the time that soldering iron is in contact with the capacitor terminals.

(4) When using equipment such as a UV curing oven for pre-heating and adhesive hardening, do not set the temperature above 150°C.

If the temperature is higher than this, the external sleeve may crack and the end seal may suffer reduced performance.

(5) Never perform reflow soldering on Green-Cap using infrared or atmospheric methods.

### 6. Circuit Board Cleaning

Circuit board can be immersed or ultrasonically cleaned using suitable cleaning solvents for up to 5 minutes and up to 60°C maximum temperature. The board should be thoroughly rinsed and dried. Recommended cleaning solvent include. Pine Alpha ST-100S, Sunelec B-12, DK beclear CW-5790, Aqua Cleaner 210SEP, Cold Cleaner P3-375, Telpen Cleaner EC 7R, Clean-thru 750H, Clean-thru 750L, Clean-thru 710M, Techno Cleaner 219, Techno Care FRV-1

- Consult with us if you are using a solvent other than any of those listed above
- The use of ozone depelting cleaning agents are not recommended in the interest of protecting the environment

## 7. CONNECT IN SERIES

Voltage balancing is needed to ensure uniform voltage distribution across each capacitor, if capacitors are connected in series to gain higher rated voltage.

## 8. CONSIDERATION TO ASSEMBLY CONDITION

In designing a circuit, the following matters should be ensured in advance to the capacitor's assembly on the printed wiring board (PW board).

Design the appropriate hole spacing to match the lead pitch of capacitors.

Do not locate any wiring and circuit patterns directly above the capacitor's vent.

Ensure enough free space above the capacitor's vent. The recommended space is specified in the catalog or specification sheets.

In case the capacitor's vent is facing the PW board, make a gas release hole on PW board.

The sealing side of the screw terminal type should not face down in the application.

When the capacitors are mounted horizontally, the anode screw terminals must be positioned at the upper side.

## 9. STORAGE

- (1) Capacitors should not be stored in high temperatures or where there is a high level of humidity. The suitable storage condition is 5°C~35°C and less than 75% in relative humidity.
- (2) Capacitors should not be stored in damp condition such as water, saltwater spray or oil spray.
- (3) Do not store capacitors in an environment full of hazardous gas (hydrogen sulfide, sulfurous acid gas, nitrous acid, chlorine gas, ammonia or bromine gas).
- (4) Capacitors should not be stored under exposure to ozone, ultraviolet rays or radiation.
- (5) In order to maintain a good solderability of the parts, shelf life of parts should not exceed 1 year.
- (6) When the capacitor is stored for a long time without applying voltage, leakage current tends to increase. This returns to nominal by applying voltage. Apply voltage (Aging) before use if the capacitor is stored long time. It is recommended to apply DC working voltage to the capacitor for 30 minutes.

## 10. TECHNICAL INFORMATION

Capacitance, DCESR Test Condition :

Constant current charge with 10mA/F to  $V_R$ .

Constant voltage charge at  $V_R$  for 5 min.

Constant current discharge with 10mA/F to 0.4  $V_R$ .

Max. Peak Current : Current for 1 sec discharge from the rated voltage to the half of it in constant current discharge, The stated maximum (peak current) should not be used in normal operation and is only provided as a reference value.

$$I = \frac{1/2 V_R}{\Delta t / C + ESR_{DC}}$$

Energy

$$\text{Max. Stored Energy(Wh), } E_{\max} \text{ (Wh)} = \frac{1/2 C V_R^2}{3600}$$

$$\text{Specific Energy(Wh/kg)} = \frac{E_{\max}}{\text{weight}}$$

Cycle Life Test Condition

- 1-minute cycle at room temperature
- Constant current charge from  $1/2V_R$  to  $V_R$ .
- Constant current discharge from  $V_R$  to  $1/2V_R$ .
- Repeat the cycle for the desired number of times.

## PART NUMBER SYSTEM

### ● Single Cell Part Number System

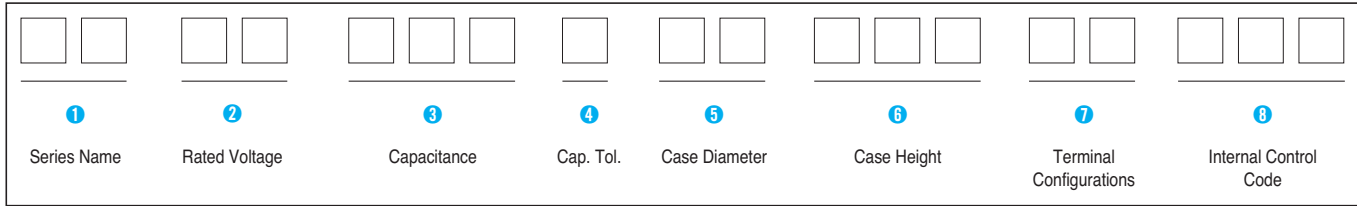

**1 Series Name**  
See page 6.

**2 Rated Working Voltage**

WV	2.5	2.7	2.85	3.0
CODE	0E	5U	5R	0U

**3 Capacitance**

ex) 1F 105  
10F 106  
100F 107  
1000F 108

**4 Capacitance Tolerance**

Tolerance (%)	±20	0~20%
Code	M	W

**5 Case Diameter**

ex) Ø10 10  
Ø16 16  
Ø18 18

**6 Case Height**

ex) 20mm 020  
25mm 025  
30mm 030

**7 Terminal Configurations**

Terminal Configurations	Code
Radial Type(LEAD)	BB
Snap-In for Soldering	HA
Lug Terminal for Soldering	LG
Threaded Terminal Type	TH
Weldable Terminal Type	WD

### ● Module Part Number System

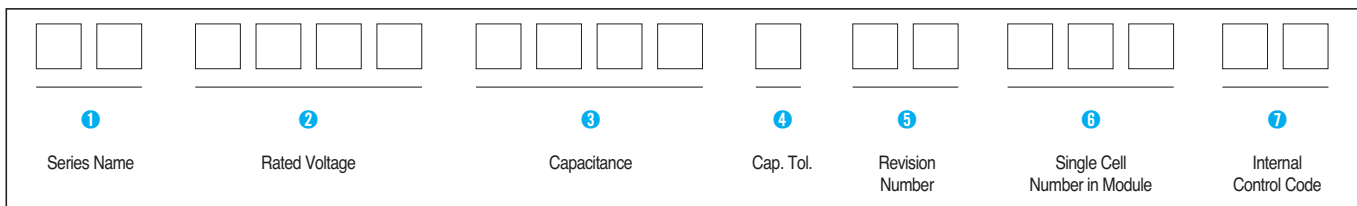

**1 Series Name**  
See page 6.

**2 Rated Working Voltage**

ex) 5.0V 0050  
13.5V 0135  
135V 1350

**3 Capacitance**

ex) 1.6F 0016  
16F 0160  
160F 1600

**4 Capacitance Tolerance**

Tolerance (%)	0 ~ +20
Code	W

**5 Revision Number**

ex) 01, 02

**6 Single Cell Number in Module**

ex) 10ea 010

# PACKING

● BLUCK TYPE PACKING

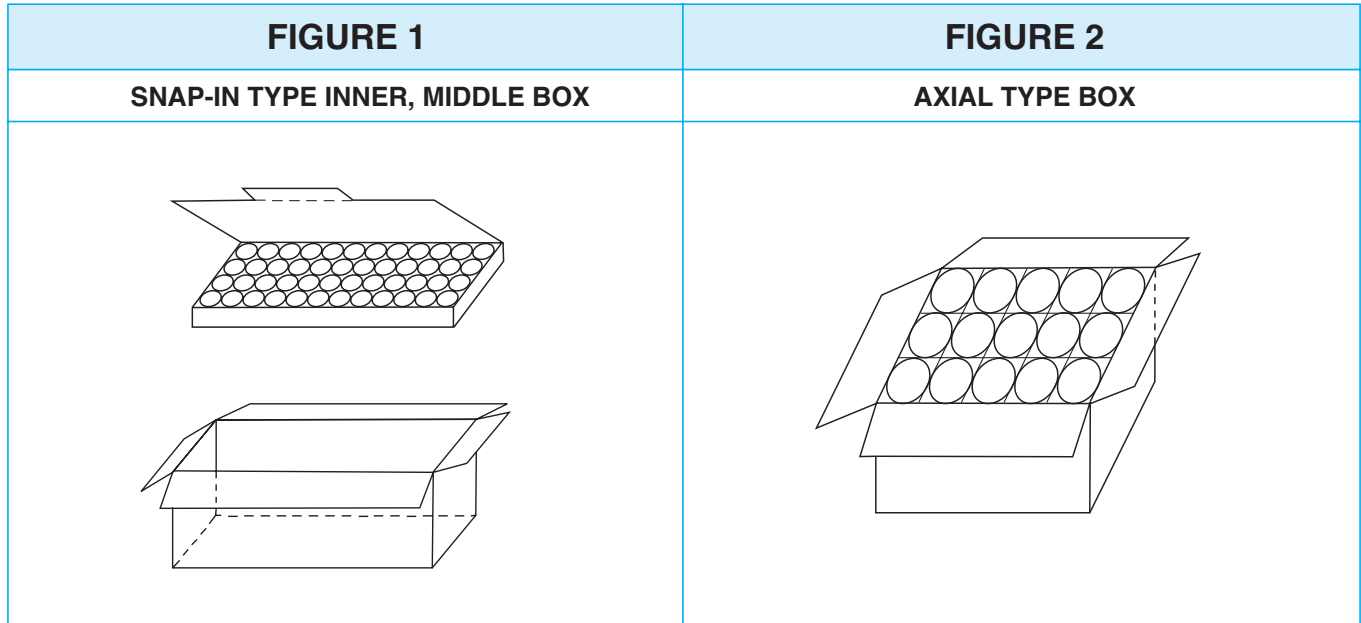

● SNAP-IN TYPE PACKING Quantity (pcs) / BOX (FIGURE 1)

SIZE		SNAP-IN(QUANTITY)	
∅D	L	INNER BOX	MIDDLE BOX
22	45, 47, 50	150	450
30	45	50	200
	60	50	150
35	50 ~ 85	50	150

● AXIAL TYPE PACKING Quantity (pcs) / BOX (FIGURE 2)

SIZE		AXIAL(QUANTITY)
∅D	L	
60	51 ~ 138	20

● RADIAL TYPE PACKING

● PACKING QUANTITY (pcs) / BOX

SIZE		BULK(QUANTITY)		
∅D	L	V-Bag	INNER BOX	MIDDLE BOX
8	20	300	2400	9600
10	20	200	1600	6400
	30	200	1200	4800
12.5	25	100	900	3600
16	25	50	500	2000
18	32	50	400	1600
	40	50	300	1200
22	45	50	150	600



# Green-Cap (ELECTRIC DOUBLE LAYER CAPACITORS)

## DM Green-Cap Module

- Low internal resistance
- Balancing and overvoltage protection of individual cell
- Efficient heat transfer to outside

### Application

- Next Generation Vehicle(FCEV, HEV) & Heavy Duty Transportation
- Short term UPS and telecommunications
- Portable Power Tool
- Wind Turbine Pitch System
- Electric Scooter
- Heavy Duty Transportation
- Golf Car

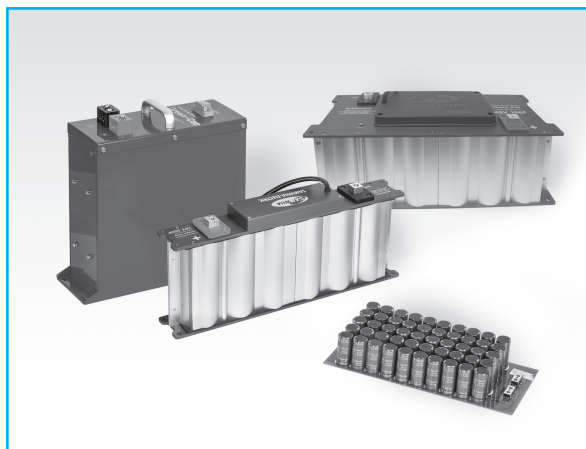

### ● Product & Spec.

Item	Characteristics	
Capacitance tolerance	0% ~ +20%	
Operating temperature range	-40 ~ +65°C, -40 ~ +85°C	
Storage Temperature Range	-40 ~ +70°C	
Temperature characteristics	Capacitance change	Within ±5% of initial value at +20°C
	Internal resistance change	Within 150% of initial value at +20°C
Endurance (65°C)	Test time	1500 hours (5.4V products are for 1000 hours)
	(1) Capacitance change	▲ Within ±30% of initial specified value
		● Within ±20% of initial specified value
	(2) Internal resistance change	Less than 100% of specified value
Shelf life (65°C)	After 1500 hours no load test same as endurance	
Life Time at RT <sup>(1)(2)</sup> (held continuously at Rated Voltage)	10 years	(1) ΔCI < 30% and ΔESR < 200% of initially specified value, respectively and LC < specified value
Cycle Life (25°C) <sup>(1)(2)</sup>	▲	500,000 cycles
	●	1,000,000 cycles
		(2) Cycle : between rated voltage and half rated voltage under constant current at 25°C

Part Number	Rated Voltage	Capacitance (F)	ESR, 1KHz (mΩ)	ESR, DC (mΩ)	Max. Continuous Current (A)		Max. Peak Current	Max. Stored Energy (Wh)	Specific Energy (Wh/kg)	Dimension(mm)			Weight (kg)	Cycle Life
					Δ T=15°C	Δ T=40°C				L	W	H		
DM00540015W01002	5.4	1.5	120	180	0.2	0.33	3.2	0.006	1.79	22.0	8.5	17.0	0.003	▲
DM00540025W01002	5.4	2.5	100	140	0.33	0.55	5.0	0.010	2.03	22.0	10.5	21.0	0.005	▲
DM00540050W01002	5.4	5.0	60	100	0.65	1.09	9.0	0.020	2.89	32.0	10.5	21.0	0.007	▲
DM01500666W01006	15	66.6	23.0	27.4	12	20	191.0	2.08	2.60	247	46	76	0.8	▲
DM01622000W01006	16.2	200.0	2.5	3.6	84	140	941.8	7.29	1.78	418	68	113	4.1	●
DM01622666W01006	16.2	266.6	2.2	3.2	90	150	1165.4	9.72	2.11	418	68	124	4.6	●
DM01623333W01006	16.2	333.3	1.8	2.5	100	167	1472.7	12.15	2.38	418	68	141	5.1	●
DM01625000W01006	16.2	500	1.4	2.0	120	200	2025.0	18.23	3.04	418	68	177	6	●
DM04860666W01018	48.6	66.6	7.6	10.8	84	140	941.8	21.87	2.19	418	191	113	10	●
DM04860888W01018	48.6	88.8	6.5	9.7	90	150	1165.4	29.16	2.54	418	191	124	11.5	●
DM04861111W01018	48.6	111.1	5.4	7.6	100	167	1472.7	36.45	2.92	418	191	141	12.5	●
DM04861666W01018	48.6	166.6	4.3	6.0	120	200	2025.0	54.68	3.65	418	191	177	15	●
DM09000100W01036	90	10.0	138.2	164.2	12	20	170.3	11.25	1.41	290	109	268	8	▲

Note : Other Green-Cap modules are supplied on custom-made basis. Dimension and Weight could be changed.  
The contents of this document are subject to change without notice.

## DH Axial Type, Standard Series



- High Power Density
- Rapid charge and discharge
- Ultra-low internal resistance

Item	Characteristics	
Operating temperature range	-40 ~ +65°C	
Rated Voltage	2.7 VDC	
Capacitance tolerance	0% ~ +20%	
Temperature characteristics	Capacitance change	Within ±5% of initial value at +20°C
	Internal resistance change	Within 100% of initial value at +20°C
Endurance (65°C)	Test time	1500 hours
	Capacitance change	Within ±20% of specified value
	Internal resistance change	Less than 100% of specified value
Shelf life (65°C)	After 1500 hours no load test same as endurance	
Life Time at RT <sup>(1)</sup>	10 years	(1)  ΔC  < 20% and ΔESR < 100% of specified value, respectively and LC < specified value
Cycle Life (25°C) <sup>(1)(2)</sup>	1,000,000 cycles	(2) Cycle : between rated voltage and half rated voltage under constant current at 25°C

### DRAWING

Unit : mm

#### Threaded Type

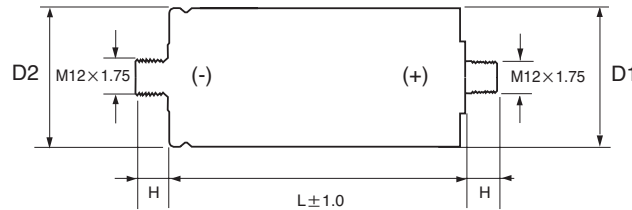
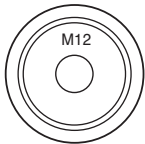

Size (mm)		
H	D1	D2
(±0.2)	(±0.2)	(±0.5)
13.0	∅60.4	∅60.7

#### Weldable Type

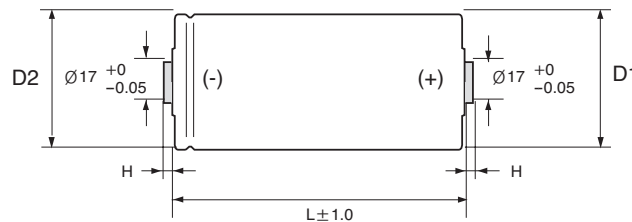
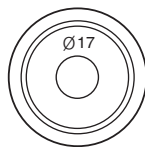

Size (mm)		
H	D1	D2
(±0.2)	(±0.2)	(±0.5)
3.0	∅60.4	∅60.7

### CHARACTERISTIC LIST & DIMENSIONS

Rated Voltage	Capacitance (F)	ESR, 1KHz (mΩ)	ESR, DC (mΩ)	LC (72hr) (mA)	Max Continuous Current(A)		Max Peak Current(A)	Specific Energy		Weight (g)	Volume (ml)	Dimension ∅D × L(mm)
					ΔT=15°C	ΔT=40°C		(Wh/kg)	(Wh/L)			
2.7	1200	0.30	0.33	2.7	98	159	1160	4.05	5.73	300	212	60.4 × 74
	1600	0.25	0.28	3.0	115	188	1492	4.76	6.65	340	244	60.4 × 85
	2000	0.24	0.27	4.0	126	206	1753	5.06	6.93	400	292	60.4 × 102
	3000	0.20	0.23	5.0	150	245	2396	5.79	7.68	525	395	60.4 × 138
	3400	0.25	0.28	9.2	130	210	2351	6.50	8.71	530	395	60.4 × 138

# Green-Cap (ELECTRIC DOUBLE LAYER CAPACITORS)

## DV Axial Type, High Voltage Series

- High Power Density
- Rapid charge and discharge
- Ultra-low internal resistance

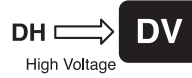

Item	Characteristics	
Operating temperature range	-40 ~ +65°C	
Rated Voltage	2.85, 3.00 VDC	
Capacitance tolerance	0% ~ +20%	
Temperature characteristics	Capacitance change	Within ±5% of initial value at +20°C
	Internal resistance change	Within 100% of initial value at +20°C
Endurance (65°C)	Test time	1500 hours
	Capacitance change	Within ±20% of specified value
	Internal resistance change	Less than 100% of specified value
Shelf life (65°C)	After 1500 hours no load test same as endurance	
Life Time at RT <sup>(1)</sup>	10 years	(1)  ΔCI  < 20% and ΔESR < 100% of specified value, respectively and LC < specified value
Cycle Life (25°C) <sup>(1)(2)</sup>	1,000,000 cycles	(2) Cycle : between rated voltage and half rated voltage under constant current at 25°C

### DRAWING

Unit : mm

#### Threaded Type

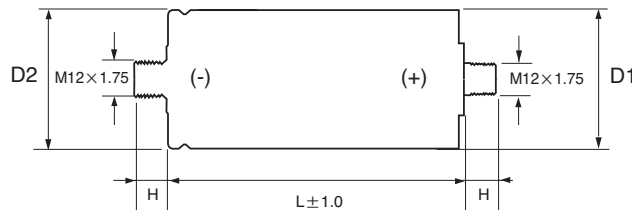
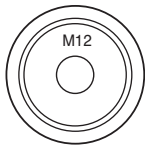

Size(mm)		
H	D1	D2
(±0.2)	(±0.2)	(±0.5)
13.0	∅60.4	∅60.7

#### Weldable Type

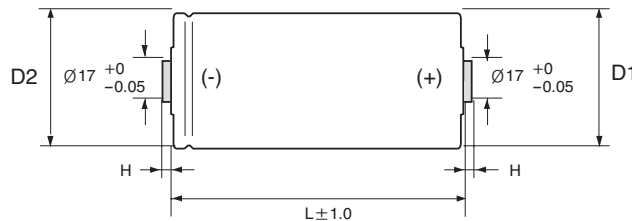
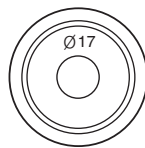

Size(mm)		
H	D1	D2
(±0.2)	(±0.2)	(±0.5)
3.0	∅60.4	∅60.7

### CHARACTERISTIC LIST & DIMENSIONS

Rated Voltage	Capacitance (F)	ESR, 1kHz (mΩ)	ESR, DC (mΩ)	LC (72hr) (mA)	Max Continuous Current(A)		Max Peak Current(A)	Specific Energy		Weight (g)	Volume (ml)	Dimension ∅D×L(mm)
					ΔT=15°C	ΔT=40°C		(Wh/kg)	(Wh/L)			
2.85	1200	0.33	0.36	3.4	94	153	1194	4.51	6.38	300	212	60.4 × 74
	1600	0.28	0.31	4.6	109	178	1524	5.31	7.41	340	244	60.4 × 85
	2000	0.27	0.30	5.7	120	195	1781	5.64	7.72	400	292	60.4 × 102
	3000	0.20	0.23	7.0	150	245	2530	6.45	8.56	525	395	60.4 × 138
	3400	0.20	0.23	8.0	150	245	2175	7.24	9.70	530	395	60.4 × 138
3.0	3000	0.20	0.23	7.0	150	245	2663	7.01	9.48	535	395	60.4 × 138

## DT Axial Type, High Temperature Series

- High Power Density
- Rapid charge and discharge
- Ultra-low internal resistance



Item	Characteristics	
Operating temperature range	-40 ~ +85°C	
Rated Voltage	2.5 VDC	
Capacitance tolerance	0% ~ +20%	
Temperature characteristics	Capacitance change	Within ±5% of initial value at +20°C
	Internal resistance change	Within 100% of initial value at +20°C
Endurance (85°C)	Test time	1500 hours
	Capacitance change	Within ±20% of specified value
	Internal resistance change	Less than 100% of specified value
Shelf life (85°C)	After 1500 hours no load test same as endurance	
Life Time at RT <sup>(1)</sup>	10 years	(1)  ΔCI  < 20% and ΔESR < 100% of specified value, respectively and LC < specified value
Cycle Life (25°C) <sup>(1)(2)</sup>	1,000,000 cycles	(2) Cycle : between rated voltage and half rated voltage under constant current at 25°C

### DRAWING

Unit : mm

#### Threaded Type

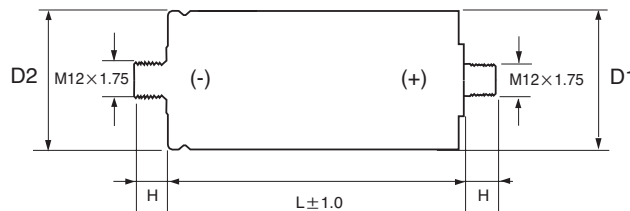
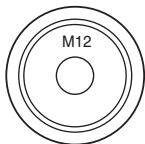

Size(mm)		
H	D1	D2
(±0.2)	(±0.2)	(±0.5)
13.0	∅60.4	∅60.7

#### Weldable Type

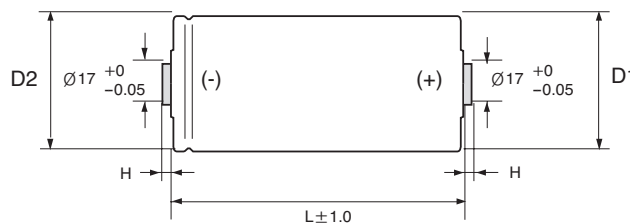

Size(mm)		
H	D1	D2
(±0.2)	(±0.2)	(±0.5)
3.0	∅60.4	∅60.7

### CHARACTERISTIC LIST & DIMENSIONS

Rated Voltage	Capacitance (F)	ESR, 1KHz (mΩ)	ESR, DC (mΩ)	LC (72hr) (mA)	Max Continuous Current(A)		Max Peak Current(A)	Specific Energy		Weight (g)	Volume (ml)	Dimension ∅D×L(mm)
					ΔT=15°C	ΔT=40°C		(Wh/kg)	(Wh/L)			
2.5	1200	0.30	0.33	2.7	98	159	1074	3.47	4.91	300	212	60.4 × 74
	1600	0.25	0.28	3.0	115	188	1381	4.08	5.70	340	244	60.4 × 85
	2000	0.24	0.27	4.0	126	206	1623	4.34	5.94	400	292	60.4 × 102
	3000	0.20	0.23	5.0	150	245	2219	4.96	6.59	525	395	60.4 × 138

# Green-Cap (ELECTRIC DOUBLE LAYER CAPACITORS)

**DB** Snap-in Terminal Type,  
Standard Series



- Endurance : 2.5V 70°C 2000 hours, 2.7V 65°C 2000 hours
- The middle size and high capacitance, low resistance
- Charge and discharge efficiency are higher than in batteries

Item	Characteristics	
Operating temperature range	-25 ~ +70°C	-40 ~ +65°C
Rated Voltage	2.5 VDC	2.7 VDC
Capacitance tolerance	-20 ~ +20% or 0% ~ +20% at 20°C	
Temperature characteristics	Capacitance change	Within ±5% of initial value at +20°C
	Internal resistance change	Within 50% of initial value at +20°C
Endurance (2.5V:70°C, 2.7V:65°C)	Test time	2000 hours
	Capacitance change	Within ±30% of specified value
	Internal resistance change	Less than 100% of specified value
Shelf life (2.5V:70°C, 2.7V:65°C)	After 2000 hours no load test same as endurance	
Life Time at RT <sup>(1)</sup>	10 years	(1) IΔCI < 30% and ΔESR < 200% of specified value, respectively and LC < specified value
Cycle Life (25°C) <sup>(1)(2)</sup>	500,000 cycles	(2) Cycle : between rated voltage and half rated voltage under constant current at 25°C

## ● DRAWING

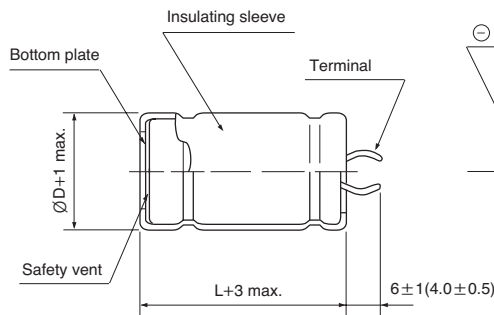

## PC Board Mounting Holes

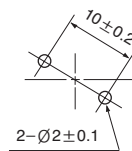

## ● Terminal

Unit : mm

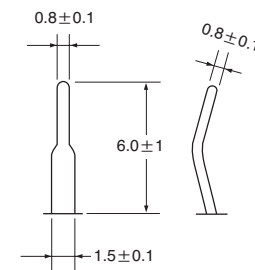

## ● CHARACTERISTIC LIST & DIMENSIONS

Rated Voltage	Capacitance (F)	ESR, 1KHz (mΩ)	ESR, DC (mΩ)	LC (72hr) (mA)	Max Continuous Current(A)		Max Peak Current(A)	Specific Energy		Weight (g)	Volume (ml)	Dimension ØD×L(mm)
					ΔT=15°C	ΔT=40°C		(Wh/kg)	(Wh/L)			
2.5	100	15.0	35.0	0.25	6.0	10.0	27.8	3.62	5.11	24	17	22 × 45
	200	10.0	20.0	0.50	8.0	13.0	50.0	4.13	5.43	42	32	30 × 45
	300	6.0	15.0	0.75	9.5	15.5	68.2	4.20	5.43	62	48	35 × 50
	360	6.0	12.0	0.90	12.0	19.5	84.6	4.17	5.39	75	58	35 × 60
	400	6.0	10.0	1.00	13.0	21.0	100.0	4.63	5.99	75	58	35 × 60
2.7	100	7.0	9.0	0.27	12.5	20.0	71.1	4.82	5.96	21	17	22 × 45
	120	7.0	9.0	0.32	12.5	20.0	77.9	5.28	6.75	23	18	22 × 47
	200	6.0	8.0	0.54	13.0	21.0	103.8	5.33	6.33	38	32	30 × 45
	300	3.5	5.0	0.81	16.0	26.5	162.0	5.33	6.33	57	48	35 × 50
	325	1.8	2.0	0.88	30.0	50.0	265.9	4.39	5.67	75	58	35 × 60
	360	3.0	3.2	0.97	23.0	38.0	225.8	5.13	6.28	71	58	35 × 60
	400	3.0	3.2	1.08	23.0	38.0	236.8	5.70	6.98	71	58	35 × 60
	400	2.8	3.0	1.08	25.0	40.0	245.5	5.06	6.43	80	63	35 × 65
	450	2.8	3.0	1.22	25.0	40.0	258.5	5.18	6.80	88	67	35 × 70
	500	2.9	3.1	1.35	25.0	40.0	264.7	5.69	7.56	89	67	35 × 70
	600	3.0	3.2	1.62	25.0	40.0	277.4	6.75	9.07	90	67	35 × 70
600	2.8	3.0	1.62	25.0	40.0	289.3	6.08	7.41	100	82	35 × 85	

## DK Snap-in Terminal Type, High Temperature Series

- Endurance : 2.7V 85°C 1500 hours
- The middle size and high capacitance, low resistance
- Charge and discharge efficiency are higher than in batteries

DB  $\Rightarrow$  **DK**  
High Temp.



Item	Characteristics	
Operating temperature range	-40 ~ +85°C	
Rated Voltage	2.7 VDC	
Capacitance tolerance	0% ~ +20%	
Temperature characteristics	Capacitance change	Within $\pm 5\%$ of initial value at +20°C
	Internal resistance change	Within 50% of initial value at +20°C
Endurance (85°C)	Test time	1500 hours
	Capacitance change	Within $\pm 30\%$ of specified value
	Internal resistance change	Less than 100% of specified value
Shelf life (85°C)	After 1500 hours no load test same as endurance	
Life Time at RT <sup>(1)</sup>	10 years	(1) $ \Delta C  < 30\%$ and $\Delta ESR < 100\%$ of specified value, respectively and LC < specified value
Cycle Life (25°C) <sup>(1)(2)</sup>	500,000 cycles	(2) Cycle : between rated voltage and half rated voltage under constant current at 25°C

### DRAWING

Unit : mm

2 PIN ( $\varnothing 22, \varnothing 30, \varnothing 35$ )	4 PIN ( $\varnothing 35$ )	LUG ( $\varnothing 35$ )
<p>Type : HA(2pin)</p>	<p>Type : HA(4pin)</p>	<p>Type : LG</p>

### CHARACTERISTIC LIST & DIMENSIONS

Rated Voltage	Capacitance (F)	ESR, 1KHz (mΩ)	ESR, DC (mΩ)	LC (72hr) (mA)	Max Continuous Current(A)		Max Peak Current(A)	Specific Energy		Weight (g)	Volume (ml)	Dimension $\varnothing D \times L$ (mm)
					$\Delta T=15^\circ C$	$\Delta T=40^\circ C$		(Wh/kg)	(Wh/L)			
2.7	100	8.0	10.0	0.27	12.0	19.0	68	4.82	5.92	21	17	22 × 45
	200	7.0	9.0	0.54	12.5	20.0	96	5.33	6.37	38	32	30 × 45
	300	3.5	5.0	0.81	16.5	27.0	162	5.33	6.31	57	48	35 × 50
	360	3.2	3.8	0.97	21.5	35.0	205	5.13	6.31	71	58	35 × 60
	400	3.2	3.8	1.08	21.5	35.0	214	5.70	7.02	71	58	35 × 60



# Green-Cap (ELECTRIC DOUBLE LAYER CAPACITORS)

**DA** Snap-in Terminal Type,  
High Voltage Series



- Endurance : 3.0V 65°C 1500 hours
- The middle size and high capacitance, low resistance
- Charge and discharge efficiency are higher than in batteries

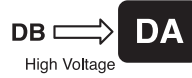

Item	Characteristics	
Operating temperature range	-40 ~ +65°C	
Rated Voltage	3.0 VDC	
Capacitance tolerance	0% ~ +20%	
Temperature characteristics	Capacitance change	Within ±5% of initial value at +20°C
	Internal resistance change	Within 50% of initial value at +20°C
Endurance (65°C)	Test time	1500 hours
	Capacitance change	Within ±30% of specified value
	Internal resistance change	Less than 100% of specified value
Shelf life (65°C)	After 1000 hours no load test same as endurance	
Life Time at RT <sup>(1)</sup>	10 years	(1) $I\Delta C < 30\%$ and $\Delta ESR < 100\%$ of specified value, respectively and $LC < \text{specified value}$
Cycle Life (25°C) <sup>(1)(2)</sup>	500,000 cycles	(2) Cycle : between rated voltage and half rated voltage under constant current at 25°C

## DRAWING

Unit : mm

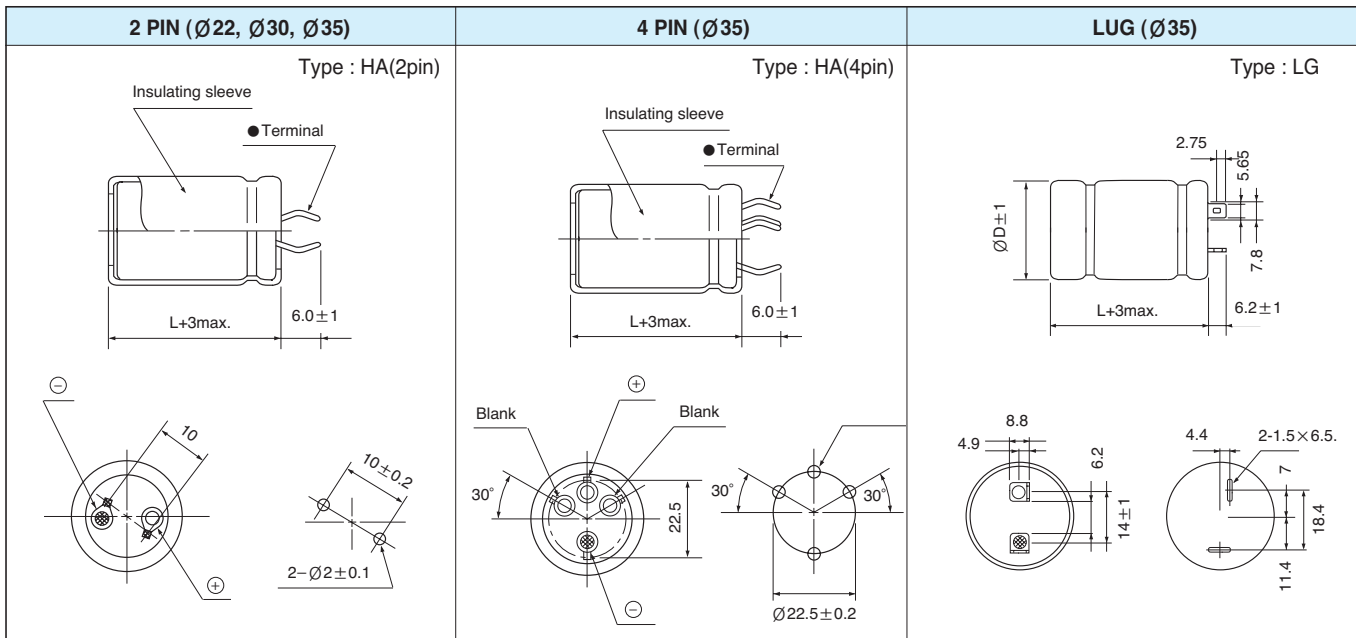

## CHARACTERISTIC LIST & DIMENSIONS

Rated Voltage	Capacitance (F)	ESR, 1KHz (mΩ)	ESR, DC (mΩ)	LC (72hr) (mA)	Max Continuous Current(A)		Max Peak Current(A)	Specific Energy		Weight (g)	Volume (ml)	Dimension ØD×L(mm)
					ΔT=15°C	ΔT=40°C		(Wh/kg)	(Wh/L)			
3.0	100	7.0	9.0	0.30	12.5	20.0	79	5.95	7.31	21	17	22 × 45
	200	6.0	8.0	0.60	13.0	21.0	115	6.58	7.86	38	32	30 × 45
	300	3.5	5.0	0.90	16.0	26.5	180	6.58	7.80	57	48	35 × 50
	360	3.2	3.8	1.08	23.0	38.0	228	6.43	7.80	70	58	35 × 60
	380	3.0	3.2	1.00	25.0	40.0	257	6.60	8.23	72	58	35 × 60
	430	2.8	3.0	1.00	25.0	40.0	282	6.72	8.59	80	63	35 × 65
480	2.8	3.0	1.00	25.0	40.0	295	6.82	8.91	88	67	35 × 70	

## DS Radial Type, Standard Series

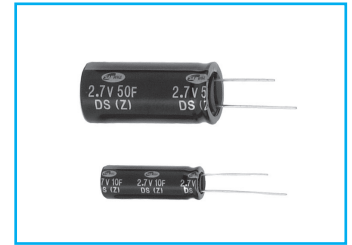

- Endurance : 2.5V 70°C 1000 hours, 2.7V 65°C 1000 hours, 3.0V 65°C 1000 hours
- The small size and high capacitance, low resistance
- Can be charge and discharge more times than secondary batteries

Item	Characteristics		
	Operating temperature range	-30 ~ +70°C	-40 ~ +65°C
Rated Voltage	2.5 VDC	2.7 VDC	3.0 VDC
Capacitance tolerance	0 ~ +20% at 20°C		
Temperature characteristics	Capacitance change	Within ±5% of initial value at +20°C	
	Internal resistance change	Within 50% of initial value at +20°C	
Endurance (2.5V:70°C, 2.7V:65°C, 3.0V:65°C)	Test time	1000 hours	
	Capacitance change	Within ±30% of specified value	
	Internal resistance change	Less than 100% of specified value	
Shelf life (2.5V:70°C, 2.7V:65°C, 3.0V:65°C)	After 1000 hours no load test same as endurance		
Life Time at RT <sup>(1)</sup>	10 years	(1)  ΔC  < 30% and ΔESR < 100% of specified value, respectively and LC < specified value	
Cycle Life (25°C) <sup>(1)(2)</sup>	500,000 cycles	(2) Cycle : between rated voltage and half rated voltage under constant current at 25°C	

### DRAWING

Unit : mm

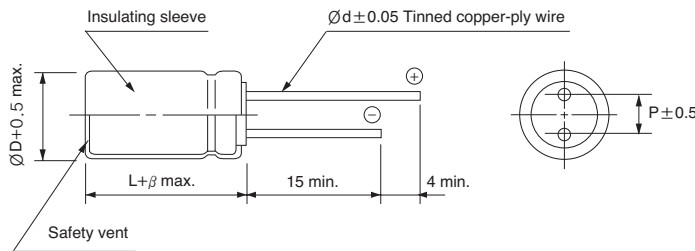

ØD	8	10	16	18
P	3.5	5.0	7.5	7.5
Ød	0.6	0.6	0.8	0.8
β	1.5	2.0		

### CHARACTERISTIC LIST & DIMENSIONS

Rated Voltage	Capacitance (F)	ESR, 1KHz (mΩ)	ESR, DC (mΩ)	LC (72hr) (mA Max.)	Specific Energy		Specific Power		Weight (g)	Volume (ml)	Dimension ØD×L(mm)
					(Wh/kg)	(Wh/L)	(W/kg)	(W/L)			
2.5	3	120	260	0.007	1.63	2.60	1,803	2,885	1.6	1.0	8 × 20
	5	70	150	0.010	1.97	2.71	2,273	3,125	2.2	1.6	10 × 20
	10	55	100	0.020	2.48	3.62	2,143	3,125	3.5	2.4	10 × 30
	25	35	65	0.020	2.89	4.34	1,538	2,308	7.5	5.0	16 × 25
	50	20	30	0.120	3.15	4.26	1,812	2,451	13.8	10.2	18 × 40
2.7	3	50	80	0.007	2.17	3.04	7,811	10,935	1.4	1.0	8 × 20
	5	45	60	0.010	2.41	3.16	6,943	9,113	2.1	1.6	10 × 20
	10	25	45	0.023	3.49	4.22	6,703	8,100	2.9	2.4	10 × 30
	15	20	40	0.030	3.38	4.90	4,860	7,055	4.5	3.1	12.5 × 25
	25	15	25	0.045	3.78	5.06	5,223	6,998	6.7	5.0	16 × 25
	33	11	20	0.060	3.34	4.13	4,374	5,400	10.0	8.1	18 × 32
	50	9	15	0.075	4.40	4.96	5,071	5,718	11.5	10.2	18 × 40
	100	8	13	0.180	4.82	5.92	3,204	3,935	21.0	17.1	22 × 45
3.0	3	60	105	0.010	2.34	3.75	6,429	10,286	1.6	1.0	8 × 20
	5	50	90	0.015	2.84	3.91	5,455	7,500	2.2	1.6	10 × 20
	10	30	45	0.030	3.57	5.21	6,857	10,000	3.5	2.4	10 × 30
	15	25	40	0.050	4.17	6.05	6,000	8,710	4.5	3.1	12.5 × 25
	25	20	30	0.070	4.17	6.25	4,800	7,200	7.5	5.0	16 × 25
	50	10	20	0.150	4.53	6.13	3,913	5,294	13.8	10.2	18 × 40

# Green-Cap (ELECTRIC DOUBLE LAYER CAPACITORS)

**DJ** Radial Type,  
High Temperature Series

- Endurance : 2.5V 85°C 1000 hours
- The small size and high capacitance, low resistance
- Can be charge and discharge more times than secondary batteries

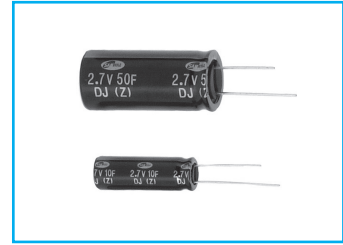

DS → **DJ**  
High Temp.

Item	Characteristics	
Operating temperature range	-40 ~ +85°C	
Rated Voltage	2.5 VDC	
Capacitance tolerance	0% ~ +20% at 20°C	
Temperature characteristics	Capacitance change	Within ±5% of initial value at +20°C
	Internal resistance change	Within 50% of initial value at +20°C
Endurance (85°C)	Test time	1000 hours
	Capacitance change	Within ±30% of specified value
	Internal resistance change	Less than 100% of specified value
Shelf life (85°C)	After 1000 hours no load test same as endurance	
Life Time at RT <sup>(1)</sup>	10 years	(1)  ΔCI  < 30% and ΔESR < 100% of specified value, respectively and LC < specified value
Cycle Life (25°C) <sup>(1)(2)</sup>	500,000 cycles	(2) Cycle : between rated voltage and half rated voltage under constant current at 25°C

## ● DRAWING

Unit : mm

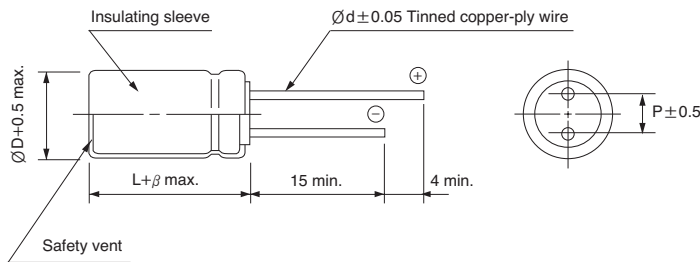

ØD	8	10	16	18
P	3.5	5.0	7.5	7.5
Ød	0.6	0.6	0.8	0.8
β	1.5	2.0		

## ● CHARACTERISTIC LIST & DIMENSIONS

Rated Voltage	Capacitance (F)	ESR, 1KHz (mΩ)	ESR, DC (mΩ)	LC (72hr) (mA Max.)	Specific Energy		Specific Power		Weight (g)	Volume (ml)	Dimension ØD×L(mm)
					(Wh/kg)	(Wh/L)	(W/kg)	(W/L)			
2.5	3	60	105	0.008	1.63	2.60	4,464	7,143	1.6	1.0	8 × 20
	5	50	90	0.013	1.97	2.71	3,788	5,208	2.2	1.6	10 × 20
	10	30	45	0.025	2.48	3.62	4,762	6,944	3.5	2.4	10 × 30
	15	25	40	0.050	2.89	4.20	4,167	6,048	4.5	3.1	12.5 × 25
	25	20	30	0.063	2.89	4.34	3,333	5,000	7.5	5.0	16 × 25
	50	10	20	0.150	3.15	4.26	2,717	3,676	13.8	10.2	18 × 40

## **2** CONDUCTIVE POLYMER HYBRID ALUMINUM ELECTROLYTIC CAPACITORS

---

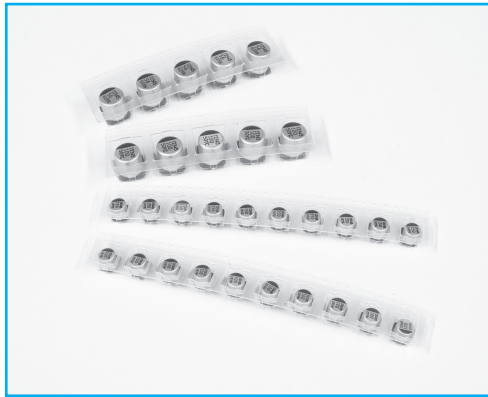

# CONDUCTIVE POLYMER HYBRID ALUMINUM ELECTROLYTIC CAPACITORS

## 1. Conductive Polymer Hybrid Aluminum Electrolytic Capacitor?

Conductive Polymer Hybrid Capacitor consist of Conductive Polymer Electric materials and Liquid Electrolyte as Electrolyte

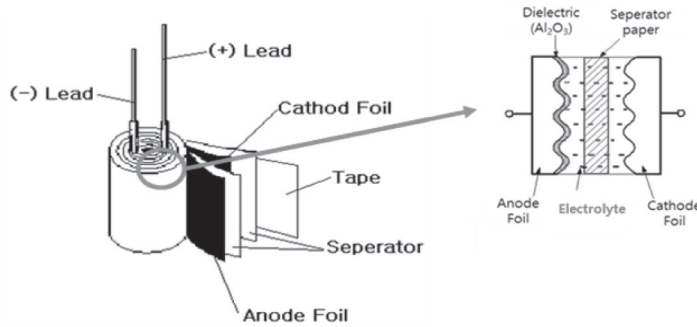

Section	Electrolytic Cap.	Solid Cap.	Hybrid Cap.
Electrolyte	Liquid Electrolyte	Conductive Polymer	Conductive Polymer + Liquid Electrolyte

## 2. Merits of Conductive Polymer Hybrid Aluminum Electrolytic Capacitor

By using conductive polymer as electrolyte, low ESR characteristics and high ripple characteristics can be realized. Low leakage current and short defect of capacitor can be prevented by electrolytic solution.

## 3. Characteristic

Section	Electrolyte Cap.	Solid Cap.	Hybrid cap.
SIZE	O	△	◎
ESR	X	O	◎
TEMPERATURE	X	O	◎
DISSIPATION FACTOR	X	O	◎
RIPPLE CURRENT	X	O	◎
RELIABILITY	X	O	◎
LEAKAGE CURRENT	O	X	◎

◎ Excellent    O Good    △ Average    X Weak

● Taping Specifications for Chip Type Capacitors

● Carrier Tape

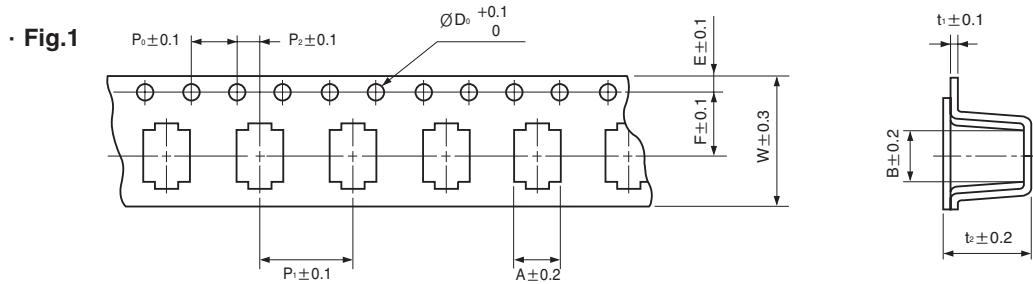

ØD×L	A	B	ØD <sub>0</sub>	E	F	P <sub>0</sub>	P <sub>1</sub>	P <sub>2</sub>	t <sub>1</sub>	t <sub>2</sub>	W
6.3 × 5.8	7.0	7.0	1.5	1.75	7.5	4.0	12.0	2.0	0.4	5.7	16.0
6.3 × 7.7	7.0	7.0	1.5	1.75	7.5	4.0	12.0	2.0	0.4	8.3	16.0
8 × 10	8.7	8.7	1.5	1.75	11.5	4.0	16.0	2.0	0.4	11.1	24.0
10 × 10	10.7	10.7	1.5	1.75	11.5	4.0	16.0	2.0	0.4	11.1	24.0
10 × 12.5	10.7	10.7	1.5	1.75	11.5	4.0	16.0	2.0	0.5	13.1	24.0

HYBRID TYPES

● Reel (Taping code : VR, VG)

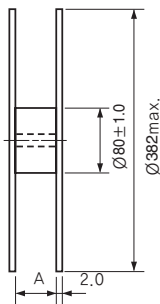
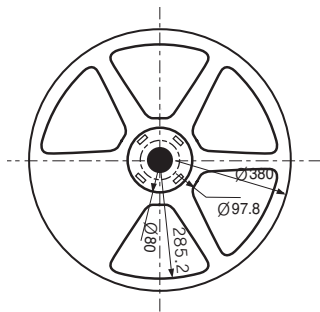

● Polarity

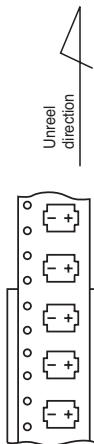

● Recommended Land Size

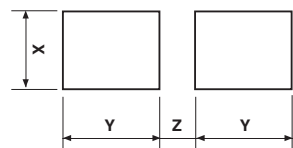

ØD×L	A	ØD×L	Q'ty/Reel(pcs.)	Q'ty/Box(pcs.)
6.3 × 5.8	16	6.3 × 5.8	1000	10000
6.3 × 7.7	16	6.3 × 7.7	900	9000
8 × 10	24	8 × 10	500	5000
10 × 10	24	10 × 10	500	5000
10 × 12.5	24	10 × 12.5	400	4000

Type	ØD×L	X	Y	Z
VR	6.3 × 5.8	1.6	3.5	2.0
	6.3 × 7.7	1.6	3.5	2.0
	8 × 10	2.5	3.5	3.0
	10 × 10	2.5	4.0	4.0
	10 × 12.5	2.5	4.0	4.0
VG	6.3 × 7.7	3.0	4.0	1.6
	8 × 10	4.3	5.3	2.0
	10 × 10	4.3	5.6	3.3
	10 × 12.5	4.3	5.6	3.3



# CONDUCTIVE POLYMER HYBRID ALUMINUM ELECTROLYTIC CAPACITORS

**YC** Chip type, Standard Series



- Endurance with ripple current: 10000 hours at 105°C
- Complied to the RoHS directive
- AEC-Q200 compliant : Please contact us for more details.

Item	Characteristics					
Operating temperature range	-55 ~ +105°C					
Leakage current max.	I = 0.01CV or 3μA whichever is greater (after 2 minutes)					
Capacitance tolerance	±20% at 120Hz, 20°C					
Dissipation factor max. (at 120Hz, 20°C)	WV	16	25	35	50	63 ~ 100
	tanδ	0.16	0.14	0.12	0.10	0.08
Low temperature characteristics (Impedance ratio at 100kHz)	Z (-25°C) / Z (+20°C) ≤ 1.5 Z (-55°C) / Z (+20°C) ≤ 2.0					
Load life	After an application of DC bias voltage plus the rated AC ripple current for 10000 hours at 105°C. The measurement shall meet the following limits. The DC voltage plus the peak AC voltage combined must not exceed the rated voltage.					
	Capacitance change	Within ±30% of initial value				
	tanδ	Less than 200% of the specified value				
	ESR	Less than 200% of the specified value				
Shelf life (at 105°C)	After 1000 hours no load test, leakage current, capacitance and tanδ are same as load life value. The measurement shall be performed at 20°C by the KS C IEC 60384 - 4					
	The following specifications shall be satisfied when the capacitors are restored to 20°C after exposing them at 250°C for 10 seconds.					
Resistance to soldering heat	Leakage current	Less than specified value				
	Capacitance change	Within ±10% of initial value				
	tanδ	Less than specified value				

## ● DRAWING

Unit : mm

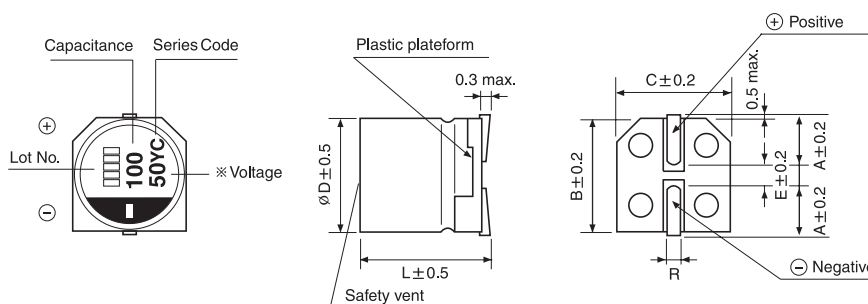

∅D×L	A	B	C	E	R
6.3×5.8	2.4	6.6	6.6	2.2	0.5~0.8
6.3×7.7	2.4	6.6	6.6	2.2	0.5~0.8
8×10	2.9	8.3	8.3	3.1	0.8~1.1
10×10	3.2	10.3	10.3	4.5	0.8~1.1
10×12.5	3.2	10.3	10.3	4.5	0.8~1.1

YC series

● DIMENSIONS & MAXIMUM PERMISSIBLE RIPPLE CURRENT

$\mu\text{F}$ \diagdown WV	16			25			35		
47							6.3×5.8	60	1300
56				6.3×5.8	50	1300			
68				6.3×7.7	30	2000	6.3×7.7	35	2000
82	6.3×5.8	45	1600						
100				6.3×7.7	30	2000	8×10	27	2300
150	6.3×7.7	27	2200	8×10	27	2300	8×10	27	2300
							10×10	20	2500
220				8×10	27	2300			
270	8×10	22	2500	10×10	20	2500	10×10	20	2500
330				10×10	20	2500	10×12.5	16	2800
470	10×10	18	2600	10×12.5	16	2800			
560	10×12.5	14	3000						

$\mu\text{F}$ \diagdown WV	50			63			80		
10				6.3×5.8	120	1000			
22	6.3×5.8	80	1100	6.3×7.7	80	1500	8×10	45	1600
33	6.3×7.7	40	1600	8×10	40	1600			
39							10×10	35	1700
47	8×10	30	1800	8×10	40	1600	10×10	35	1700
56				10×10	30	1800			
68	8×10	30	1800				10×12.5	32	2400
82				10×10	30	1800			
100	10×10	25	2000	10×12.5	20	2400			
150	10×12.5	18	2400						

$\mu\text{F}$ \diagdown WV	100		
10	8×10	60	1450
15	10×10	45	1500
18	10×12.5	40	1580

Ripple current (mA rms) at 105°C, 100kHz  
 ESR (mΩ) at 20°C, 100kHz  
 Case size  $\varnothing D \times L$  (mm)

HYBRID TYPES

● FREQUENCY COEFFICIENT OF PERMISSIBLE RIPPLE CURRENT

Frequency	120Hz	1kHz	10kHz	100kHz
Coefficient	0.05	0.30	0.70	1.00

# CONDUCTIVE POLYMER HYBRID ALUMINUM ELECTROLYTIC CAPACITORS

**YH** Chip type, High Temperature Series



- High temperature range, for 125°C use
- Complied to the RoHS directive
- AEC-Q200 compliant : Please contact us for more details.

Item	Characteristics												
Operating temperature range	-55 ~ +125°C												
Leakage current max.	$I = 0.01CV$ or $3\mu A$ whichever is greater (after 2 minutes)												
Capacitance tolerance	$\pm 20\%$ at 120Hz, 20°C												
Dissipation factor max. (at 120Hz, 20°C)	<table border="1"> <tr> <td>WV</td> <td>16</td> <td>25</td> <td>35</td> <td>50</td> <td>63 ~ 100</td> </tr> <tr> <td><math>\tan\delta</math></td> <td>0.16</td> <td>0.14</td> <td>0.12</td> <td>0.10</td> <td>0.08</td> </tr> </table>	WV	16	25	35	50	63 ~ 100	$\tan\delta$	0.16	0.14	0.12	0.10	0.08
WV	16	25	35	50	63 ~ 100								
$\tan\delta$	0.16	0.14	0.12	0.10	0.08								
Low temperature characteristics (Impedance ratio at 100kHz)	$Z(-25^\circ C) / Z(+20^\circ C) \leq 1.5$ $Z(-55^\circ C) / Z(+20^\circ C) \leq 2.0$												
Load life	<p>After an application of DC bias voltage plus the rated AC ripple current for 4000 hours at 125°C. The measurement shall meet the following limits. The DC voltage plus the peak AC voltage combined must not exceed the rated voltage.</p> <table border="1"> <tr> <td>Capacitance change</td> <td>Within <math>\pm 30\%</math> of initial value</td> </tr> <tr> <td><math>\tan\delta</math></td> <td>Less than 200% of the specified value</td> </tr> <tr> <td>ESR</td> <td>Less than 200% of the specified value</td> </tr> <tr> <td>Leakage current</td> <td>Less than specified value</td> </tr> </table>	Capacitance change	Within $\pm 30\%$ of initial value	$\tan\delta$	Less than 200% of the specified value	ESR	Less than 200% of the specified value	Leakage current	Less than specified value				
Capacitance change	Within $\pm 30\%$ of initial value												
$\tan\delta$	Less than 200% of the specified value												
ESR	Less than 200% of the specified value												
Leakage current	Less than specified value												
Shelf life(at 125°C)	After 1000 hours no load test, leakage current, capacitance and $\tan\delta$ are same as load life value. The measurement shall be performed at 20°C by the KS C IEC 60384 - 4												
Resistance to soldering heat	<p>The following specifications shall be satisfied when the capacitors are restored to 20°C after exposing them at 250°C for 10 seconds.</p> <table border="1"> <tr> <td>Leakage current</td> <td>Less than specified value</td> </tr> <tr> <td>Capacitance change</td> <td>Within <math>\pm 10\%</math> of initial value</td> </tr> <tr> <td><math>\tan\delta</math></td> <td>Less than specified value</td> </tr> </table>	Leakage current	Less than specified value	Capacitance change	Within $\pm 10\%$ of initial value	$\tan\delta$	Less than specified value						
Leakage current	Less than specified value												
Capacitance change	Within $\pm 10\%$ of initial value												
$\tan\delta$	Less than specified value												

## DRAWING

Unit : mm

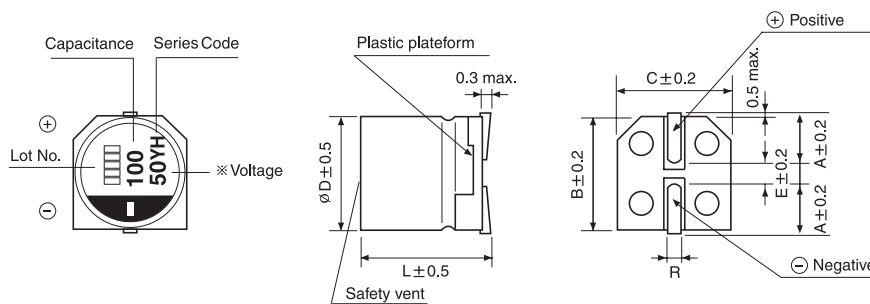

$\phi D \times L$	A	B	C	E	R
6.3×5.8	2.4	6.6	6.6	2.2	0.5~0.8
6.3×7.7	2.4	6.6	6.6	2.2	0.5~0.8
8×10	2.9	8.3	8.3	3.1	0.8~1.1
10×10	3.2	10.3	10.3	4.5	0.8~1.1
10×12.5	3.2	10.3	10.3	4.5	0.8~1.1

## YH series

### ● DIMENSIONS & MAXIMUM PERMISSIBLE RIPPLE CURRENT

$\mu\text{F}$ \diagdown WV	16			25			35		
47							6.3×5.8	60	900
56				6.3×5.8	50	900			
68				6.3×7.7	30	1400	6.3×7.7	35	1400
82	6.3×5.8	45	1000						
100				6.3×7.7	30	1400	8×10	27	1600
150	6.3×7.7	27	1450	8×10	27	1600	8×10	27	1600
							10×10	20	2000
220				8×10	27	1600			
270	8×10	22	1700	10×10	20	2000	10×10	20	2000
330				10×10	20	2000	10×12.5	16	2260
470	10×10	18	2100	10×12.5	16	2260			
560	10×12.5	14	2320						

$\mu\text{F}$ \diagdown WV	50			63			80		
10				6.3×5.8	120	700			
22	6.3×5.8	80	750	6.3×7.7	80	900	8×10	45	1100
33	6.3×7.7	40	1100	8×10	40	1100			
39							10×10	35	1360
47	8×10	30	1250	8×10	40	1100	10×10	35	1360
56				10×10	30	1400			
68	8×10	30	1250				10×12.5	32	1700
82				10×10	30	1400			
100	10×10	25	1600	10×12.5	20	2100			
150	10×12.5	18	2250						

$\mu\text{F}$ \diagdown WV	100		
10	8×10	60	900
15	10×10	45	1120
18	10×12.5	40	1220

Ripple current (mA rms) at 125°C, 100kHz  
 ESR (mΩ) at 20°C, 100kHz  
 Case size  $\varnothing D \times L$  (mm)

HYBRID TYPES

### ● FREQUENCY COEFFICIENT OF PERMISSIBLE RIPPLE CURRENT

Frequency	120Hz	1kHz	10kHz	100kHz
Coefficient	0.05	0.30	0.70	1.00

# CONDUCTIVE POLYMER HYBRID ALUMINUM ELECTROLYTIC CAPACITORS

**YK** Chip type, High Temperature Series



- High temperature compared with YH series
- High temperature range, for 135°C use
- Complied to the RoHS directive
- AEC-Q200 compliant : Please contact us for more details.



Item	Characteristics				
Operating temperature range	-55 ~ +135°C				
Leakage current max.	I = 0.01CV or 3μA whichever is greater (after 2 minutes)				
Capacitance tolerance	±20% at 120Hz, 20°C				
Dissipation factor max. (at 120Hz, 20°C)	WV	25	35	50	63
	tanδ	0.14	0.12	0.10	0.08
Low temperature characteristics (Impedance ratio at 100kHz)	Z (-25°C) / Z (+20°C) ≤ 1.5 Z (-55°C) / Z (+20°C) ≤ 2.0				
Load life	After an application of DC bias voltage plus the rated AC ripple current for 4000 hours(2000 hours for ØD=6.3) at 135°C. The measurement shall meet the following limits. The DC voltage plus the peak AC voltage combined must not exceed the rated voltage.				
	Capacitance change	Within ±30% of initial value			
	tanδ	Less than 200% of the specified value			
	ESR	Less than 200% of the specified value			
	Leakage current	Less than specified value			
Shelf life(at 135°C)	After 1000 hours no load test, leakage current, capacitance and tanδ are same as load life value. The measurement shall be performed at 20°C by the KS C IEC 60384 - 4				
Resistance to soldering heat	The following specifications shall be satisfied when the capacitors are restored to 20°C after exposing them at 250°C for 10 seconds.				
	Leakage current	Less than specified value			
	Capacitance change	Within ±10% of initial value			
	tanδ	Less than specified value			

## ● DRAWING

Unit : mm

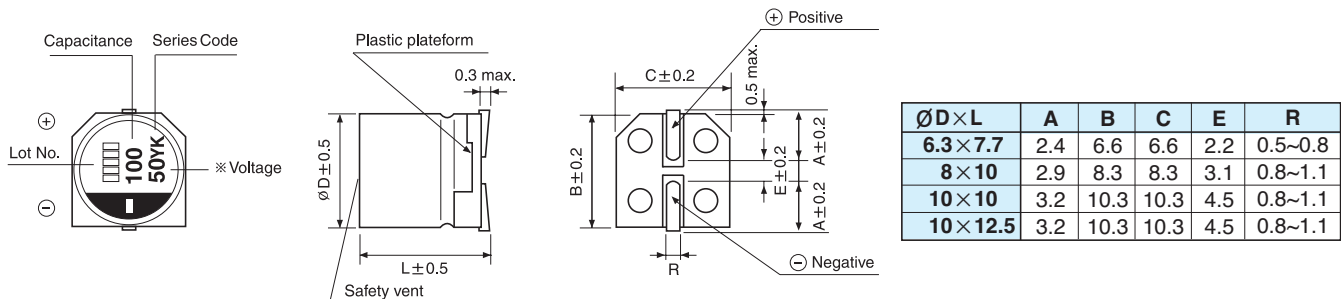

## ● DIMENSIONS & MAXIMUM PERMISSIBLE RIPPLE CURRENT

μF	WV	25		35		50		63		
	33								8×10	40
47						8×10	30	1250		
56								10×10	30	1400
68				6.3×7.7	35	1400				
82										
100	6.3×7.7	30	1400			10×10	25	1600		
150				8×10	27	1600				
220										
270	8×10	27	1600	10×10	20	2000				
330	10×10	20	2000	10×12.5	17	2260				
470	10×12.5	16	2260							

← Ripple current (mA rms) at 135°C, 100kHz

↑ ESR (mΩ) at 20°C, 100kHz  
Case size ØD×L (mm)

## ● FREQUENCY COEFFICIENT OF PERMISSIBLE RIPPLE CURRENT

Frequency	120Hz	1kHz	10kHz	100kHz
Coefficient	0.05	0.30	0.70	1.00

## YT Chip type, Ultra High Temperature Series



- High temperature range, for 150°C use
- Complied to the RoHS directive
- AEC-Q200 compliant : Please contact us for more details.

Item	Characteristics										
Operating temperature range	-55 ~ +150°C										
Leakage current max.	$I = 0.01CV$ or $3\mu A$ whichever is greater (after 2 minutes)										
Capacitance tolerance	$\pm 20\%$ at 120Hz, 20°C										
Dissipation factor max. (at 120Hz, 20°C)	<table border="1"> <tr> <td>WV</td> <td>25</td> <td>35</td> <td>50</td> <td>63</td> </tr> <tr> <td><math>\tan\delta</math></td> <td>0.14</td> <td>0.12</td> <td>0.1</td> <td>0.08</td> </tr> </table>	WV	25	35	50	63	$\tan\delta$	0.14	0.12	0.1	0.08
WV	25	35	50	63							
$\tan\delta$	0.14	0.12	0.1	0.08							
Low temperature characteristics (Impedance ratio at 100kHz)	$Z(-25^\circ C) / Z(+20^\circ C) \leq 1.5$ $Z(-55^\circ C) / Z(+20^\circ C) \leq 2.0$										
Load life	<p>After an application of DC bias voltage plus the rated AC ripple current for 1000 hours at 150°C. The measurement shall meet the following limits. The DC voltage plus the peak AC voltage combined must not exceed the rated voltage.</p> <table border="1"> <tr> <td>Capacitance change</td> <td>Within <math>\pm 30\%</math> of initial value</td> </tr> <tr> <td><math>\tan\delta</math></td> <td>Less than 200% of the specified value</td> </tr> <tr> <td>ESR</td> <td>Less than 200% of the specified value</td> </tr> <tr> <td>Leakage current</td> <td>Less than specified value</td> </tr> </table>	Capacitance change	Within $\pm 30\%$ of initial value	$\tan\delta$	Less than 200% of the specified value	ESR	Less than 200% of the specified value	Leakage current	Less than specified value		
Capacitance change	Within $\pm 30\%$ of initial value										
$\tan\delta$	Less than 200% of the specified value										
ESR	Less than 200% of the specified value										
Leakage current	Less than specified value										
Shelf life (at 150°C)	After 1000 hours no load test, leakage current, capacitance and $\tan\delta$ are same as load life value. The measurement shall be performed at 20°C by the KS C IEC 60384 - 4										
Resistance to soldering heat	<p>The following specifications shall be satisfied when the capacitors are restored to 20°C after exposing them at 250°C for 10 seconds.</p> <table border="1"> <tr> <td>Leakage current</td> <td>Less than specified value</td> </tr> <tr> <td>Capacitance change</td> <td>Within <math>\pm 10\%</math> of initial value</td> </tr> <tr> <td><math>\tan\delta</math></td> <td>Less than specified value</td> </tr> </table>	Leakage current	Less than specified value	Capacitance change	Within $\pm 10\%$ of initial value	$\tan\delta$	Less than specified value				
Leakage current	Less than specified value										
Capacitance change	Within $\pm 10\%$ of initial value										
$\tan\delta$	Less than specified value										

HYBRID TYPES

### DRAWING

Unit : mm

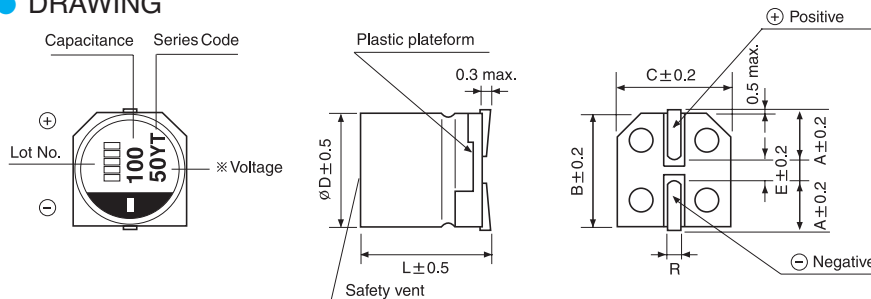

$\phi D \times L$	A	B	C	E	R
6.3×7.7	2.4	6.6	6.6	2.2	0.5~0.8
8×10	2.9	8.3	8.3	3.1	0.8~1.1
10×10	3.2	10.3	10.3	4.5	0.8~1.1
10×12.5	3.2	10.3	10.3	4.5	0.8~1.1

### DIMENSIONS & MAXIMUM PERMISSIBLE RIPPLE CURRENT

$\mu F$	WV	25		35			50			63		
15									6.3×7.7	80	410	
22									8×10	40	610	
33												
47				6.3×7.7	60	510						
56							8×10	35	660			
68	6.3×7.7	45	540							10×10	30	710
100										10×12.5	22	810
120				8×10	30	710	10×10	28	780			
150	8×10	27	740	10×10	23	830	10×12.5	19	890			
220				10×12.5	17	950						
270	10×10	22	850									
330	10×12.5	16	970									

Ripple current (mA rms) at 150°C, 100kHz  
 ESR (mΩ) at 20°C, 100kHz  
 Case size  $\phi D \times L$  (mm)

### FREQUENCY COEFFICIENT OF PERMISSIBLE RIPPLE CURRENT

Frequency	120Hz	1kHz	10kHz	100kHz
Coefficient	0.05	0.30	0.70	1.00



# CONDUCTIVE POLYMER HYBRID ALUMINUM ELECTROLYTIC CAPACITORS

**YM** Chip type, High Capacitance & High Ripple Current Series



- High ripple current compared with YH series
- High temperature range, for 125°C use
- Complied to the RoHS directive
- AEC-Q200 compliant : Please contact us for more details.

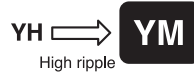

Item	Characteristics					
Operating temperature range	-55 ~ +125°C					
Leakage current max.	$I = 0.01CV$ or $3\mu A$ whichever is greater (after 2 minutes)					
Capacitance tolerance	$\pm 20\%$ at 120Hz, 20°C					
Dissipation factor max. (at 120Hz, 20°C)	WV	16	25	35	50	63
	tan $\delta$	0.16	0.14	0.12	0.1	0.08
Low temperature characteristics (Impedance ratio at 100kHz)	$Z(-25^\circ C) / Z(+20^\circ C) \leq 1.5$ $Z(-55^\circ C) / Z(+20^\circ C) \leq 2.0$					
Load life	After an application of DC bias voltage plus the rated AC ripple current for 4000 hours at 125°C. The measurement shall meet the following limits. The DC voltage plus the peak AC voltage combined must not exceed the rated voltage.					
	Capacitance change	Within $\pm 30\%$ of initial value				
	tan $\delta$	Less than 200% of the specified value				
	ESR	Less than 200% of the specified value				
	Leakage current	Less than specified value				
Shelf life (at 125°C)	After 1000 hours no load test, leakage current, capacitance and tan $\delta$ are same as load life value. The measurement shall be performed at 20°C by the KS C IEC 60384 - 4					
Resistance to soldering heat	The following specifications shall be satisfied when the capacitors are restored to 20°C after exposing them at 250°C for 10 seconds.					
	Leakage current	Less than specified value				
	Capacitance change	Within $\pm 10\%$ of initial value				
	tan $\delta$	Less than specified value				

## ● DRAWING

Unit : mm

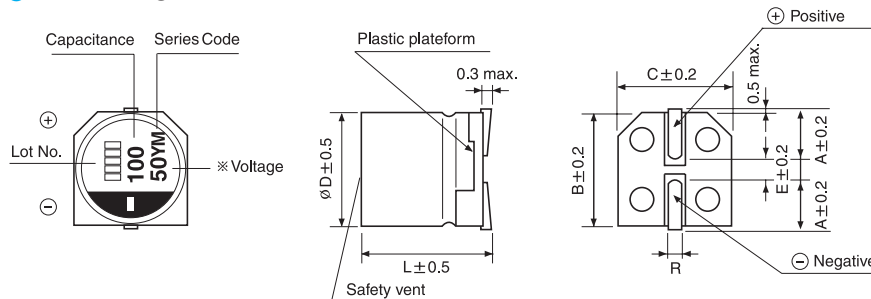

ØD×L	A	B	C	E	R
6.3×5.8	2.4	6.6	6.6	2.2	0.5~0.8
6.3×7.7	2.4	6.6	6.6	2.2	0.5~0.8
8×10	2.9	8.3	8.3	3.1	0.8~1.1
10×10	3.2	10.3	10.3	4.5	0.8~1.1
10×12.5	3.2	10.3	10.3	4.5	0.8~1.1

## ● DIMENSIONS & MAXIMUM PERMISSIBLE RIPPLE CURRENT

µF	WV	16		25		35		50		63					
47								6.3×7.7	40	1500	8×10	40	1700		
56							6.3×5.8	60	1200						
82				6.3×5.8	50	1300					10×10	30	2000		
100							6.3×7.7	35	1700	8×10	30	1700	10×12.5	20	3000
120	6.3×5.8	45	1080												
150	6.3×7.7	27	1800	6.3×7.7	30	1800	8×10	27	2000	10×10	25	2000			
180							8×10	27	2000						
220										10×12.5	18	3200			
330				8×10	27	2000	10×10	20	2800						
390	8×10	22	2000				10×12.5	16	3500						
560				10×10	20	2800									
680	10×10	18	2800	10×12.5	16	3500									
820	10×12.5	14	3500												

↑ Ripple current (mA rms) at 125°C, 100kHz  
 ↑ ESR (mΩ) at 20°C, 100kHz  
 ↑ Case size ØD×L (mm)

## ● FREQUENCY COEFFICIENT OF PERMISSIBLE RIPPLE CURRENT

Frequency	120Hz	1kHz	10kHz	100kHz
Coefficient	0.05	0.30	0.70	1.00

## YB Lead type, Standard Series

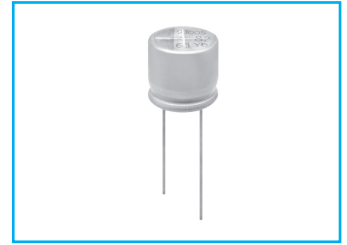

- Endurance with ripple current: 10000 hours at 105°C
- Complied to the RoHS directive
- AEC-Q200 compliant : Please contact us for more details.

Item	Characteristics												
Operating temperature range	-55 ~ +105°C												
Leakage current max.	$I = 0.01CV$ or $3\mu A$ whichever is greater (after 2 minutes)												
Capacitance tolerance	$\pm 20\%$ at 120Hz, 20°C												
Dissipation factor max. (at 120Hz, 20°C)	<table border="1"> <tr> <td>WV</td> <td>16</td> <td>25</td> <td>35</td> <td>50</td> <td>63 ~ 100</td> </tr> <tr> <td><math>\tan\delta</math></td> <td>0.16</td> <td>0.14</td> <td>0.12</td> <td>0.10</td> <td>0.08</td> </tr> </table>	WV	16	25	35	50	63 ~ 100	$\tan\delta$	0.16	0.14	0.12	0.10	0.08
WV	16	25	35	50	63 ~ 100								
$\tan\delta$	0.16	0.14	0.12	0.10	0.08								
Low temperature characteristics (Impedance ratio at 100kHz)	$Z(-25^\circ C) / Z(+20^\circ C) \leq 1.5$ $Z(-55^\circ C) / Z(+20^\circ C) \leq 2.0$												
Load life	<p>After an application of DC bias voltage plus the rated AC ripple current for 10000 hours at 105°C. The measurement shall meet the following limits. The DC voltage plus the peak AC voltage combined must not exceed the rated voltage.</p> <table border="1"> <tr> <td>Capacitance change</td> <td>Within <math>\pm 30\%</math> of initial value</td> </tr> <tr> <td><math>\tan\delta</math></td> <td>Less than 200% of the specified value</td> </tr> <tr> <td>ESR</td> <td>Less than 200% of the specified value</td> </tr> <tr> <td>Leakage current</td> <td>Less than specified value</td> </tr> </table>	Capacitance change	Within $\pm 30\%$ of initial value	$\tan\delta$	Less than 200% of the specified value	ESR	Less than 200% of the specified value	Leakage current	Less than specified value				
Capacitance change	Within $\pm 30\%$ of initial value												
$\tan\delta$	Less than 200% of the specified value												
ESR	Less than 200% of the specified value												
Leakage current	Less than specified value												
Shelf life (at 105°C)	After 1000 hours no load test, leakage current, capacitance and $\tan\delta$ are same as load life value. The measurement shall be performed at 20°C by the KS C IEC 60384 - 4												

HYBRID TYPES

### ● DRAWING

Unit : mm

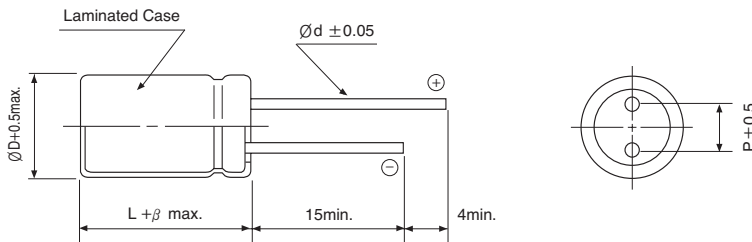

Size	ØD	L	P	Ød	β
6.3×7.5	6.3	7.5	2.5	0.45	1.0
8×9.5	8	9.5	3.5	0.60	1.0
10×9.5	10.0	9.5	5.0	0.60	1.0
10×12	10.0	12.0	5.0	0.60	1.0

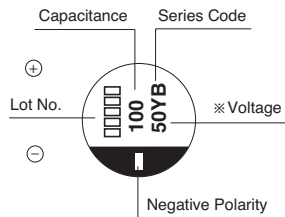

### ● PACKING & TAPING (See page 86~88)

# CONDUCTIVE POLYMER HYBRID ALUMINUM ELECTROLYTIC CAPACITORS

**YB** series

## ● DIMENSIONS & MAXIMUM PERMISSIBLE RIPPLE CURRENT

$\mu\text{F}$ \diagdown WV	16			25			35		
68				6.3×7.5	30	2000	6.3×7.5	35	2000
82									
100				6.3×7.5	30	2000	8×9.5	27	2300
150	6.3×7.5	27	2200	8×9.5	27	2300	8×9.5	27	2300
							10×9.5	20	2500
220				8×9.5	27	2300			
270	8×9.5	22	2500	10×9.5	20	2500	10×9.5	20	2500
330				10×9.5	20	2500	10×12	16	2800
470	10×9.5	18	2600	10×12	16	2800			
560	10×12	14	3000						

$\mu\text{F}$ \diagdown WV	50			63			80		
22				6.3×7.5	80	1500	8×9.5	45	1600
33	6.3×7.5	40	1600	8×9.5	40	1600			
39							10×9.5	35	1700
47	8×9.5	30	1800	8×9.5	40	1600	10×9.5	35	1700
56				10×9.5	30	1800			
68	8×9.5	30	1800				10×12	32	2400
82				10×10	30	1800			
100	10×9.5	25	2000	10×12	20	2400			
150	10×12	18	2400						

$\mu\text{F}$ \diagdown WV	100		
10	8×9.5	60	1450
15	10×9.5	45	1500
18	10×12	40	1580

Ripple current (mA rms) at 105°C, 100kHz  
 ESR (mΩ) at 20°C, 100kHz  
 Case size  $\varnothing D \times L$  (mm)

## ● FREQUENCY COEFFICIENT OF PERMISSIBLE RIPPLE CURRENT

Frequency	120Hz	1kHz	10kHz	100kHz
Coefficient	0.05	0.30	0.70	1.00

## YG Lead type, High Temperature Series

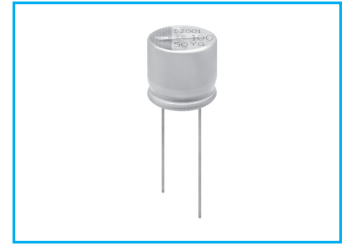

- High temperature range, for 125°C use
- Complied to the RoHS directive
- AEC-Q200 compliant : Please contact us for more details.

Item	Characteristics												
Operating temperature range	-55 ~ +125°C												
Leakage current max.	$I = 0.01CV$ or $3\mu A$ whichever is greater (after 2 minutes)												
Capacitance tolerance	$\pm 20\%$ at 120Hz, 20°C												
Dissipation factor max. (at 120Hz, 20°C)	<table border="1"> <tr> <td>WV</td> <td>16</td> <td>25</td> <td>35</td> <td>50</td> <td>63 ~ 100</td> </tr> <tr> <td><math>\tan\delta</math></td> <td>0.16</td> <td>0.14</td> <td>0.12</td> <td>0.10</td> <td>0.08</td> </tr> </table>	WV	16	25	35	50	63 ~ 100	$\tan\delta$	0.16	0.14	0.12	0.10	0.08
	WV	16	25	35	50	63 ~ 100							
$\tan\delta$	0.16	0.14	0.12	0.10	0.08								
Low temperature characteristics (Impedance ratio at 100kHz)	$Z(-25^\circ C) / Z(+20^\circ C) \leq 1.5$ $Z(-55^\circ C) / Z(+20^\circ C) \leq 2.0$												
Load life	After an application of DC bias voltage plus the rated AC ripple current for 4000 hours at 125°C. The measurement shall meet the following limits. The DC voltage plus the peak AC voltage combined must not exceed the rated voltage.												
	Capacitance change	Within $\pm 30\%$ of initial value											
	$\tan\delta$	Less than 200% of the specified value											
	ESR	Less than 200% of the specified value											
Shelf life (at 125°C)	Leakage current	Less than specified value											
	After 1000 hours no load test, leakage current, capacitance and $\tan\delta$ are same as load life value. The measurement shall be performed at 20°C by the KS C IEC 60384 - 4												

HYBRID TYPES

### ● DRAWING

Unit : mm

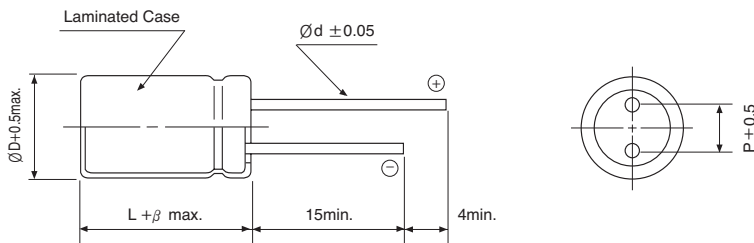

Size	ØD	L	P	Ød	β
6.3×7.5	6.3	7.5	2.5	0.45	1.0
8×9.5	8	9.5	3.5	0.60	1.0
10×9.5	10.0	9.5	5.0	0.60	1.0
10×12	10.0	12.0	5.0	0.60	1.0

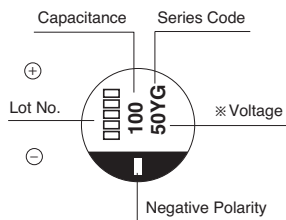

### ● PACKING & TAPING (See page 86~88)

# CONDUCTIVE POLYMER HYBRID ALUMINUM ELECTROLYTIC CAPACITORS

**YG** series

## ● DIMENSIONS & MAXIMUM PERMISSIBLE RIPPLE CURRENT

$\mu\text{F}$ \diagdown WV	16			25			35		
68				6.3×7.5	30	1400	6.3×7.5	35	1400
82									
100				6.3×7.5	30	1400	8×9.5	27	1600
150	6.3×7.5	27	1450	8×9.5	27	1600	8×9.5	27	1600
							10×9.5	20	2000
220				8×9.5	27	1600			
270	8×9.5	22	1700	10×9.5	20	2000	10×9.5	20	2000
330				10×9.5	20	2000	10×12	16	2260
470	10×9.5	18	2100	10×12	16	2260			
560	10×12	14	2320						

$\mu\text{F}$ \diagdown WV	50			63			80		
22				6.3×7.5	80	900	8×9.5	45	1100
33	6.3×7.5	40	1100	8×9.5	40	1100			
39							10×9.5	35	1360
47	8×9.5	30	1250	8×9.5	40	1100	10×9.5	35	1360
56				10×9.5	30	1400			
68	8×9.5	30	1250				10×12	32	1700
82				10×10	30	1400			
100	10×9.5	25	1600	10×12	20	2100			
150	10×12	18	2250						

$\mu\text{F}$ \diagdown WV	100		
10	8×10	60	900
15	10×10	45	1120
18	10×12.5	40	1220

Ripple current (mA rms) at 125°C, 100kHz  
 ESR (mΩ) at 20°C, 100kHz  
 Case size  $\varnothing D \times L$  (mm)

## ● FREQUENCY COEFFICIENT OF PERMISSIBLE RIPPLE CURRENT

Frequency	120Hz	1kHz	10kHz	100kHz
Coefficient	0.05	0.30	0.70	1.00

## YJ Lead type, High Temperature Series

- High temperature compared with YG series
- High temperature range, for 135°C use
- Complied to the RoHS directive

YG → **YJ**  
High Temp.

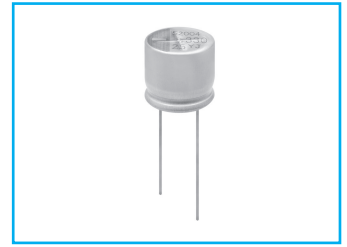

Item	Characteristics				
Operating temperature range	-55 ~ +135°C				
Leakage current max.	I = 0.01CV or 3μA whichever is greater (after 2 minutes)				
Capacitance tolerance	±20% at 120Hz, 20°C				
Dissipation factor max. (at 120Hz, 20°C)	WV	25	35	50	63
	tanδ	0.14	0.12	0.1	0.08
Low temperature characteristics (Impedance ratio at 100kHz)	$Z(-25^{\circ}\text{C}) / Z(+20^{\circ}\text{C}) \leq 1.5$ $Z(-55^{\circ}\text{C}) / Z(+20^{\circ}\text{C}) \leq 2.0$				
Load life	After an application of DC bias voltage plus the rated AC ripple current for 4000 hours(2000 hours for $\phi D=6.3$ ) at 135°C. The measurement shall meet the following limits. The DC voltage plus the peak AC voltage combined must not exceed the rated voltage.				
	Capacitance change	Within ±30% of initial value			
	tanδ	Less than 200% of the specified value			
	ESR	Less than 200% of the specified value			
Shelf life(at 135°C)	After 1000 hours no load test, leakage current, capacitance and tanδ are same as load life value. The measurement shall be performed at 20°C by the KS C IEC 60384 - 4				

HYBRID TYPES

### ● DRAWING

Unit : mm

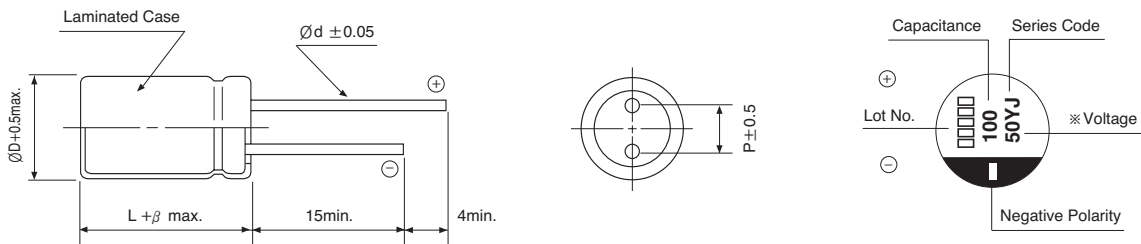

Size	$\phi D$	L	P	$\phi d$	$\beta$
6.3×7.5	6.3	7.5	2.5	0.45	1.0
8×9.5	8	9.5	3.5	0.60	1.0
10×9.5	10.0	9.5	5.0	0.60	1.0
10×12	10.0	12.0	5.0	0.60	1.0

### ● PACKING & TAPING (See page 86~88)

# CONDUCTIVE POLYMER HYBRID ALUMINUM ELECTROLYTIC CAPACITORS

**YJ** series

## ● DIMENSIONS & MAXIMUM PERMISSIBLE RIPPLE CURRENT

$\mu\text{F}$ \diagdown WV	25			35			50			63		
33										8×9.5	40	1100
47							8×9.5	30	1250			
56										10×9.5	30	1400
68				6.3×7.5	35	1400						
82												
100	6.3×7.5	30	1400				10×9.5	25	1600			
150				8×9.5	27	1600						
220												
270	8×9.5	27	1600	10×9.5	20	2000						
330	10×9.5	20	2000	10×12	17	2260						
470	10×12	16	2260									

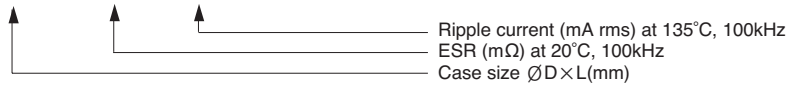

## ● FREQUENCY COEFFICIENT OF PERMISSIBLE RIPPLE CURRENT

Frequency	120Hz	1kHz	10kHz	100kHz
Coefficient	0.05	0.30	0.70	1.00



## YF Lead type, Ultra High Temperature Series

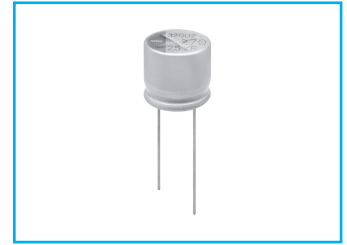

- High temperature range, for 150°C use
- Complied to the RoHS directive
- AEC-Q200 compliant : Please contact us for more details.

Item	Characteristics				
Operating temperature range	-55 ~ +150°C				
Leakage current max.	I = 0.01CV or 3μA whichever is greater (after 2 minutes)				
Capacitance tolerance	±20% at 120Hz, 20°C				
Dissipation factor max. (at 120Hz, 20°C)	WV	25	35	50	63
	tanδ	0.14	0.12	0.1	0.08
Low temperature characteristics (Impedance ratio at 100kHz)	Z (-25°C) / Z (+20°C) ≤ 1.5 Z (-55°C) / Z (+20°C) ≤ 2.0				
Load life	After an application of DC bias voltage plus the rated AC ripple current for 1000 hours at 150°C. The measurement shall meet the following limits. The DC voltage plus the peak AC voltage combined must not exceed the rated voltage.				
	Capacitance change	Within ±30% of initial value			
	tanδ	Less than 200% of the specified value			
	ESR	Less than 200% of the specified value			
Shelf life (at 150°C)	After 1000 hours no load test, leakage current, capacitance and tanδ are same as load life value. The measurement shall be performed at 20°C by the KS C IEC 60384 - 4				

HYBRID TYPES

### ● DRAWING

Unit : mm

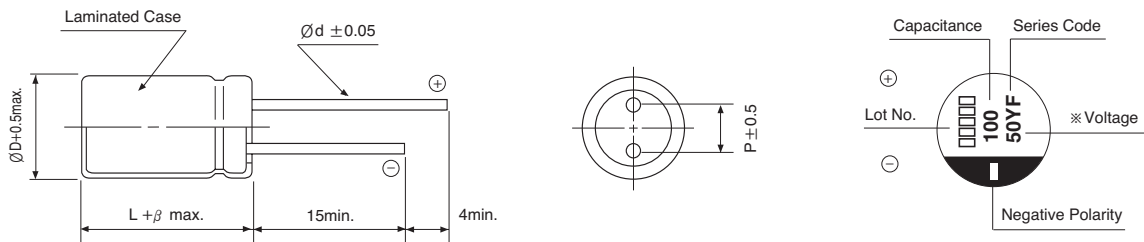

Size	øD	L	P	ød	β
6.3×7.5	6.3	7.5	2.5	0.45	1.0
8×9.5	8	9.5	3.5	0.60	1.0
10×9.5	10.0	9.5	5.0	0.60	1.0
10×12	10.0	12.0	5.0	0.60	1.0

### ● PACKING & TAPING (See page 86~88)

### ● DIMENSIONS & MAXIMUM PERMISSIBLE RIPPLE CURRENT

μF	WV	25			35			50			63		
15										6.3×7.5	80	410	
22							6.3×7.5	80	410				
33										8×9.5	40	610	
47				6.3×7.5	60	510							
56							8×9.5	35	660	10×9.5	30	710	
68	6.3×7.5	45	540							10×12	22	810	
100				8×9.5	30	710	10×9.5	28	780				
120							10×12	19	890				
150	8×9.5	27	740	10×9.5	23	830							
220				10×12	17	950							
270	10×9.5	22	850										
330	10×12	16	970										

↑ Ripple current (mA rms) at 150°C, 100kHz  
 ↑ ESR (mΩ) at 20°C, 100kHz  
 ↑ Case size øD×L(mm)

### ● FREQUENCY COEFFICIENT OF PERMISSIBLE RIPPLE CURRENT

Frequency	120Hz	1kHz	10kHz	100kHz
Coefficient	0.05	0.30	0.70	1.00

# CONDUCTIVE POLYMER HYBRID ALUMINUM ELECTROLYTIC CAPACITORS



Lead type, High Capacitance & High Ripple Current Series

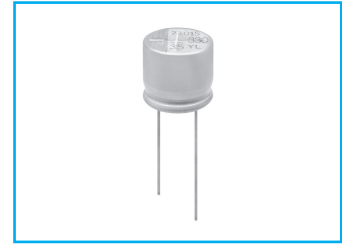

- High ripple current compared with YG series
- High temperature range, for 125°C use
- Complied to the RoHS directive
- AEC-Q200 compliant : Please contact us for more details.



Item	Characteristics												
Operating temperature range	-55 ~ +125°C												
Leakage current max.	$I = 0.01CV$ or $3\mu A$ whichever is greater (after 2 minutes)												
Capacitance tolerance	$\pm 20\%$ at 120Hz, 20°C												
Dissipation factor max. (at 120Hz, 20°C)	<table border="1"> <tr> <td>WV</td> <td>16</td> <td>25</td> <td>35</td> <td>50</td> <td>63</td> </tr> <tr> <td>tan<math>\delta</math></td> <td>0.16</td> <td>0.14</td> <td>0.12</td> <td>0.1</td> <td>0.08</td> </tr> </table>	WV	16	25	35	50	63	tan $\delta$	0.16	0.14	0.12	0.1	0.08
	WV	16	25	35	50	63							
tan $\delta$	0.16	0.14	0.12	0.1	0.08								
Low temperature characteristics (Impedance ratio at 100kHz)	$Z(-25^\circ C) / Z(+20^\circ C) \leq 1.5$ $Z(-55^\circ C) / Z(+20^\circ C) \leq 2.0$												
Load life	After an application of DC bias voltage plus the rated AC ripple current for 4000 hours at 125°C. The measurement shall meet the following limits. The DC voltage plus the peak AC voltage combined must not exceed the rated voltage.												
	Capacitance change	Within $\pm 30\%$ of initial value											
	tan $\delta$	Less than 200% of the specified value											
	ESR	Less than 200% of the specified value											
Shelf life (at 125°C)	Less than specified value												
	After 1000 hours no load test, leakage current, capacitance and tan $\delta$ are same as load life value. The measurement shall be performed at 20°C by the KS C IEC 60384 - 4												

## DRAWING

Unit : mm

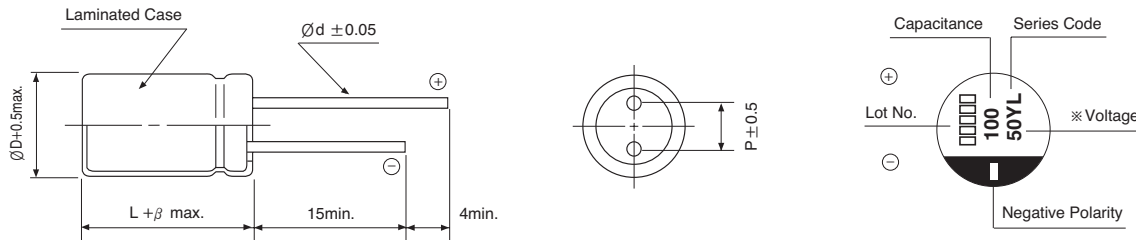

Size	∅D	L	P	∅d	β
6.3×7.5	6.3	7.5	2.5	0.45	1.0
8×9.5	8	9.5	3.5	0.60	1.0
10×9.5	10.0	9.5	5.0	0.60	1.0
10×12	10.0	12.0	5.0	0.60	1.0

## PACKING & TAPING (See page 86~88)

## DIMENSIONS & MAXIMUM PERMISSIBLE RIPPLE CURRENT

μF	WV	16		25		35		50			63			
47								6.3×7.5	40	1500	8×9.5	40	1700	
82											10×9.5	30	2000	
100						6.3×7.5	35	1700	8×9.5	30	1700	10×12	20	3000
150	6.3×7.5	27	1800	6.3×7.5	30	1800	8×9.5	27	2000	10×9.5	25	2000		
180							8×10	27	2000					
220										10×12	18	3200		
330				8×9.5	27	2000	10×9.5	20	2800					
390	8×9.5	22	2000				10×12	16	3500					
560				10×9.5	20	2800								
680	10×9.5	18	2800	10×12	16	3500								
820	10×12	14	3500											

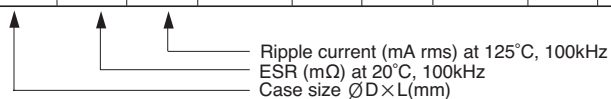

# 3 SURFACE MOUNT ALUMINUM ELECTROLYTIC CAPACITORS

---

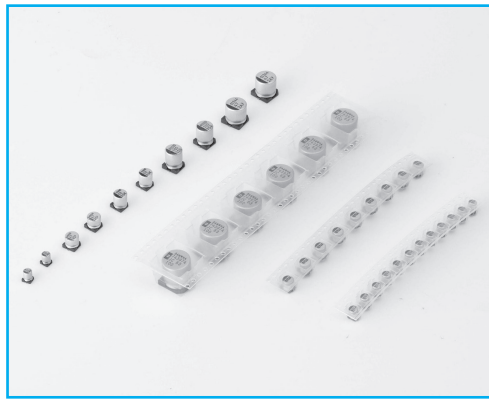

# SURFACE MOUNT ALUMINUM ELECTROLYTIC CAPACITORS

## ● Taping Specifications for Chip Type Capacitors

### ● Carrier Tape

Fig.1

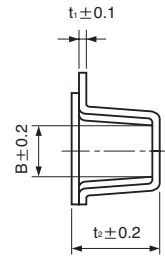
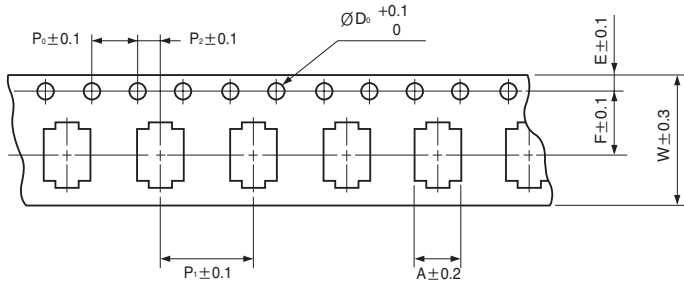
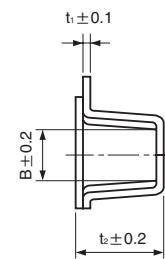
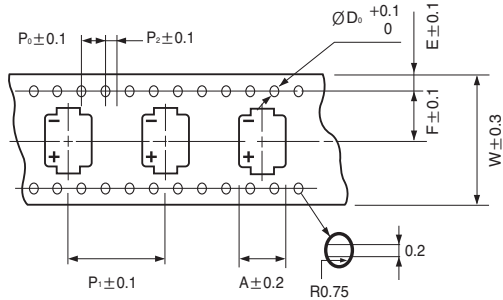

Fig.2



ØD×L	A	B	ØD <sub>0</sub>	E	F	P <sub>0</sub>	P <sub>1</sub>	P <sub>2</sub>	t <sub>1</sub>	t <sub>2</sub>	W	Fig.	
4 × 5.3	4.7	4.7	1.5	1.75	5.5	4.0	8.0	2.0	0.4	5.7	12.0	1	
5 × 5.3	5.7	5.7	1.5	1.75	5.5	4.0	12.0	2.0	0.4	5.7	12.0		
6.3 × 5.3	7.0	7.0	1.5	1.75	7.5	4.0	12.0	2.0	0.4	5.7	16.0		
6.3 × 5.8	7.0	7.0	1.5	1.75	7.5	4.0	12.0	2.0	0.4	6.3	16.0		
6.3 × 7.7	7.0	7.0	1.5	1.75	7.5	4.0	12.0	2.0	0.4	8.2	16.0		
8 × 6.2	8.7	8.7	1.5	1.75	7.5	4.0	12.0	2.0	0.4	6.8	16.0		
8 × 10	8.7	8.7	1.5	1.75	11.5	4.0	16.0	2.0	0.4	11.0	24.0		
10 × 10	10.7	10.7	1.5	1.75	11.5	4.0	16.0	2.0	0.4	11.0	24.0		
12.5 × 13.5	14.0	14.0	1.5	1.75	14.2	4.0	24.0	2.0	0.5	14.0	32.0		2

### ● Reel

Fig.1(PAPER)

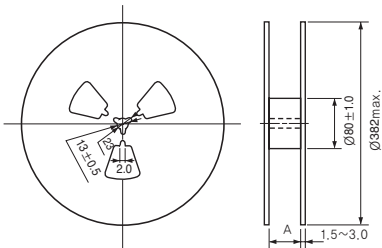
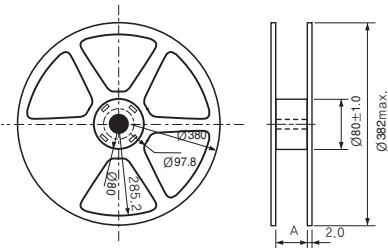
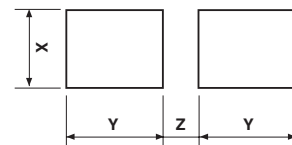

Fig.2(PLASTIC)



### ● Recommended Land Size



### ● Polarity

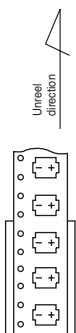

ØD×L	A		ØD×L	Q'ty/Reel(pcs.)	Q'ty/Box(pcs.)
	Fig.1	Fig.2			
4 × 5.3	14	12	4 × 5.3	2000	20000
5 × 5.3	14	12	5 × 5.3	1000	10000
6.3 × 5.3	18	16	6.3 × 5.3	1000	10000
6.3 × 5.8	18	16	6.3 × 5.8	1000	10000
6.3 × 7.7	18	16	6.3 × 7.7	900	9000
8 × 6.2	18	16	8 × 6.2	1000	10000
8 × 10	26	24	8 × 10	500	3000
10 × 10	26	24	10 × 10	500	3000
12.5 × 13.5	34	32	12.5 × 13.5	200	1000

Type	ØD×L	X	Y	Z
VR	4×5.3	1.6	2.6	1.0
	5×5.3	1.6	3.0	1.4
	6.3×5.3	1.6	3.5	2.0
	6.3×5.8	1.6	3.5	2.0
	6.3×7.7	1.6	3.5	2.0
	8×6.2	2.5	4.0	2.0
	8×10	2.5	3.5	3.0
	10×10	2.5	4.0	4.0
	12.5×13.5	2.5	5.7	4.0
	VG	6.3×7.7	3.0	4.0
8×10		4.3	5.3	2.0
10×10		4.3	5.6	3.3
12.5×13.5		7.0	7.3	3.0

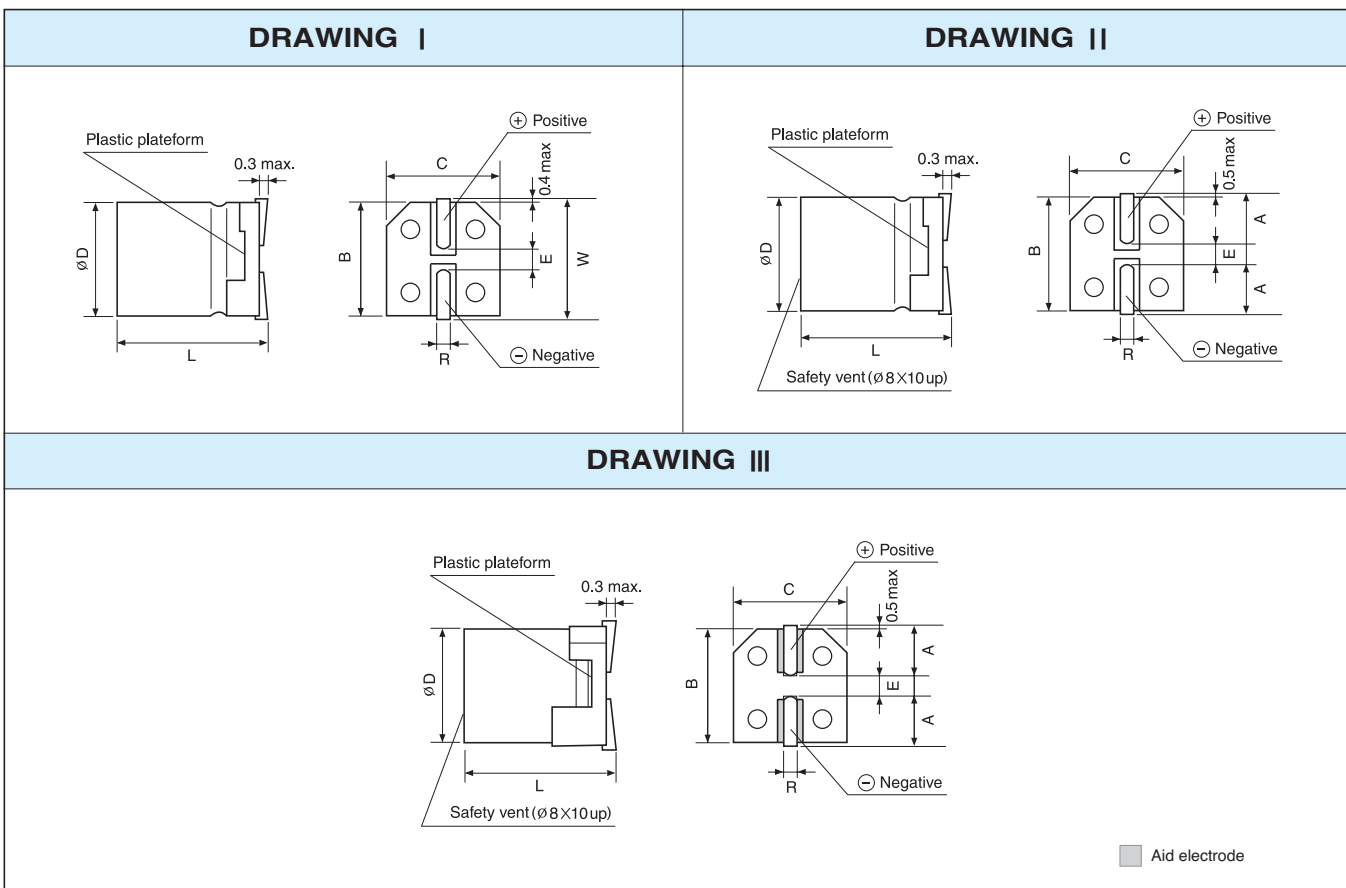

## ● DIMENSION OF STANDARD TYPE

APPLICABLE DRAWING NO.	$\varnothing \times D$	$B \pm 0.2$	$C \pm 0.2$	$E \pm 0.2$	$A \pm 0.2$	R
DRAWING I	4×5.3	4.3	4.3	1.0	4.8	0.5 ~ 0.8
	5×5.3	5.3	5.3	1.4	5.8	0.5 ~ 0.8

APPLICABLE DRAWING NO.	$\varnothing \times D$	$B \pm 0.2$	$C \pm 0.2$	$E \pm 0.2$	$A \pm 0.2$	R
DRAWING II	6.3×5.3	6.6	6.6	2.2	2.4	0.5 ~ 0.8
	6.3×5.8	6.6	6.6	2.2	2.4	0.5 ~ 0.8
	6.3×7.7	6.6	6.6	2.2	2.4	0.5 ~ 0.8
	8×6.2	8.3	8.3	2.3	3.3	0.5 ~ 0.8
	8×10	8.3	8.3	3.1	2.9	0.8 ~ 1.1
	10×10	10.3	10.3	4.5	3.2	0.8 ~ 1.1
	10×12.5	10.3	10.3	4.5	3.2	0.8 ~ 1.1
12.5×13.5	12.8	12.8	4.5	4.6	1.3 ~ 1.6	

## ● DIMENSION OF VIBRATION RESISTANT TYPE(FOR 30G)

APPLICABLE DRAWING NO.	$\varnothing \times D$	$B \pm 0.2$	$C \pm 0.2$	$E \pm 0.2$	$A \pm 0.2$	R
DRAWING III	6.3×7.7	6.6	6.6	2.2	2.4	0.5 ~ 0.8
	8×10	8.3	8.3	3.1	2.9	0.8 ~ 1.1
	10×10	10.3	10.3	4.5	3.2	0.8 ~ 1.1
	12.5×13.5	12.8	12.8	4.5	4.6	1.3 ~ 1.6

# SURFACE MOUNT ALUMINUM ELECTROLYTIC CAPACITORS

**SC** Chip type, Standard Series

**S**  
Solvent Proof  
WV ≤ 100V

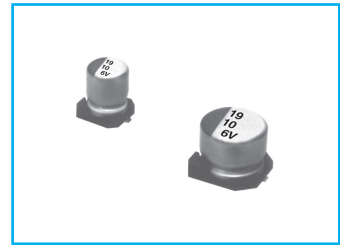

- Chip type higher capacitance in larger case sizes
- Designed for surface mounting on high density PC board
- Applicable to automatic insertion machine using carrier tape
- Complied to the RoHS directive
- AEC-Q200 compliant : Please contact us for more details.



Item	Characteristics																														
Operating temperature range	-40 ~ +85°C																														
Leakage current max.	WV ≤ 100 I = 0.01CV or 3μA whichever is greater (after 2 minutes) WV ≥ 160 I = 0.04CV + 100μA(after 1 minutes)																														
Capacitance tolerance	±20% at 120Hz, 20°C																														
Dissipation factor max. (at 120Hz, 20°C)	<table border="1"> <tr> <td>WV</td> <td>4</td> <td>6.3</td> <td>10</td> <td>16</td> <td>25</td> <td>35</td> <td>50</td> <td>63</td> <td>100</td> <td>160</td> <td>200</td> <td>250</td> <td>400</td> <td>450</td> </tr> <tr> <td>tanδ</td> <td>0.40</td> <td>0.35</td> <td>0.24</td> <td>0.20</td> <td>0.16</td> <td>0.13</td> <td>0.12</td> <td>0.12</td> <td>0.12</td> <td>0.20</td> <td>0.20</td> <td>0.20</td> <td>0.25</td> <td>0.25</td> </tr> </table>	WV	4	6.3	10	16	25	35	50	63	100	160	200	250	400	450	tanδ	0.40	0.35	0.24	0.20	0.16	0.13	0.12	0.12	0.12	0.20	0.20	0.20	0.25	0.25
WV	4	6.3	10	16	25	35	50	63	100	160	200	250	400	450																	
tanδ	0.40	0.35	0.24	0.20	0.16	0.13	0.12	0.12	0.12	0.20	0.20	0.20	0.25	0.25																	
Low temperature characteristics (Impedance ratio at 120Hz)	<table border="1"> <tr> <td>WV</td> <td>4</td> <td>6.3</td> <td>10</td> <td>16</td> <td>25</td> <td>35 ~ 100</td> <td>160 ~ 250</td> <td>400 ~ 450</td> </tr> <tr> <td>Z-25°C/Z+20°C</td> <td>6</td> <td>5</td> <td>4</td> <td>3</td> <td>2</td> <td>2</td> <td>3</td> <td>6</td> </tr> <tr> <td>Z-40°C/Z+20°C</td> <td>12</td> <td>10</td> <td>8</td> <td>6</td> <td>4</td> <td>3</td> <td>6</td> <td>10</td> </tr> </table>	WV	4	6.3	10	16	25	35 ~ 100	160 ~ 250	400 ~ 450	Z-25°C/Z+20°C	6	5	4	3	2	2	3	6	Z-40°C/Z+20°C	12	10	8	6	4	3	6	10			
WV	4	6.3	10	16	25	35 ~ 100	160 ~ 250	400 ~ 450																							
Z-25°C/Z+20°C	6	5	4	3	2	2	3	6																							
Z-40°C/Z+20°C	12	10	8	6	4	3	6	10																							
Load life (after application of the rated voltage for 2000 hours at 85°C)	<table border="1"> <tr> <td>Leakage current</td> <td>Less than specified value</td> </tr> <tr> <td>Capacitance change</td> <td>Within ±20% of initial value (Small size : ±25%)</td> </tr> <tr> <td>tanδ</td> <td>Less than 200% of the specified value</td> </tr> </table>	Leakage current	Less than specified value	Capacitance change	Within ±20% of initial value (Small size : ±25%)	tanδ	Less than 200% of the specified value																								
Leakage current	Less than specified value																														
Capacitance change	Within ±20% of initial value (Small size : ±25%)																														
tanδ	Less than 200% of the specified value																														
Shelf life(at 85°C)	After 1000 hours no load test, leakage current, capacitance and tanδ are same as load life value. The measurement shall be performed at 20°C by the KS C IEC 60384 - 4																														
Resistance to soldering heat	The following specifications shall be satisfied when the capacitors are restored to 20°C after exposing them at 250°C for 10 seconds. <table border="1"> <tr> <td>Leakage current</td> <td>Less than specified value</td> </tr> <tr> <td>Capacitance change</td> <td>Within ±10% of initial value</td> </tr> <tr> <td>tanδ</td> <td>Less than specified value</td> </tr> </table>	Leakage current	Less than specified value	Capacitance change	Within ±10% of initial value	tanδ	Less than specified value																								
Leakage current	Less than specified value																														
Capacitance change	Within ±10% of initial value																														
tanδ	Less than specified value																														

● DRAWING -Series code of SC is "V"

Unit : mm

(∅4, ∅5)

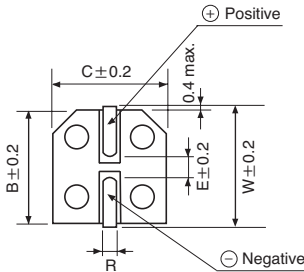
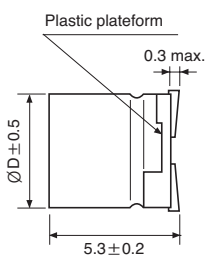
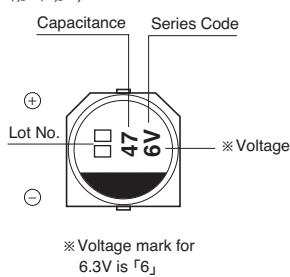

∅D × L	W	A	B	C	E	R
4 × 5.3	4.8		4.3	4.3	1.0	0.5~0.8
5 × 5.3	5.8		5.3	5.3	1.4	0.5~0.8
6.3 × 5.3		2.4	6.6	6.6	2.2	0.5~0.8
6.3 × 5.8		2.4	6.6	6.6	2.2	0.5~0.8
6.3 × 7.7		2.4	6.6	6.6	2.2	0.5~0.8
8 × 6.2		3.3	8.3	8.3	2.3	0.5~0.8
8 × 10		2.9	8.3	8.3	3.1	0.8~1.1
10 × 10		3.2	10.3	10.3	4.5	0.8~1.1
12.5 × 13.5		4.6	12.8	12.8	4.5	1.3~1.6

(∅6.3, ∅8 × 6.2)

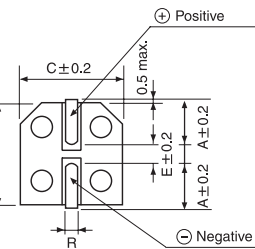
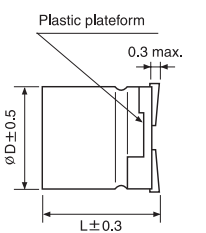
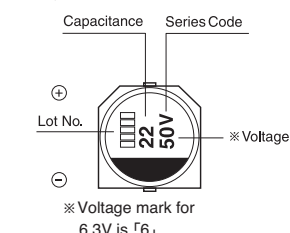

(∅12.5)

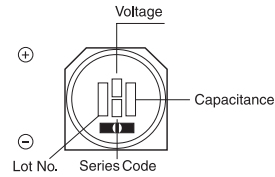

(∅8 × 10, ∅10 × 10)

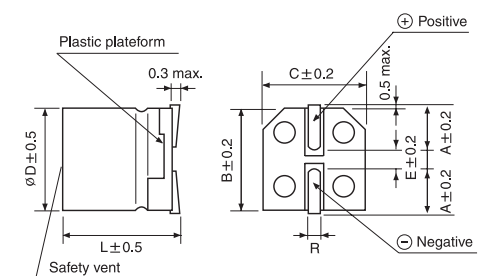
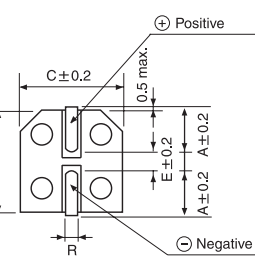
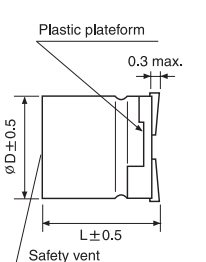
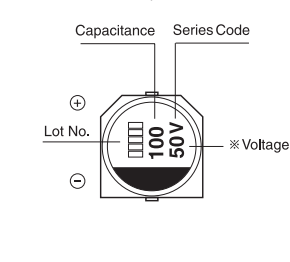

## SC series

### ● DIMENSIONS & MAXIMUM PERMISSIBLE RIPPLE CURRENT

$\mu\text{F}$ \diagdown WV	4		6.3		10		16		25		35		50																																																																																																																																																																																																																																																																																																																												
1.0													4×5.3	10																																																																																																																																																																																																																																																																																																																											
2.2											4×5.3	11	4×5.3	15																																																																																																																																																																																																																																																																																																																											
3.3									4×5.3	15	4×5.3	16	4×5.3	18																																																																																																																																																																																																																																																																																																																											
4.7							4×5.3	16	4×5.3	18	4×5.3	19	4×5.3	24														5×5.3	25	10	4×5.3	16	4×5.3	19	4×5.3	21	4×5.3	21	4×5.3	24	4×5.3	27	5×5.3	41										5×5.3	30	5×5.3	32	6.3×5.3	43	22	4×5.3	24	4×5.3	29	4×5.3	28	4×5.3	30	5×5.3	41	6.3×5.3	53	6.3×5.3	55						5×5.3	36	5×5.3	41	6.3×5.3	53			6.3×5.8	73	33	4×5.3	29	4×5.3	30	4×5.3	34	5×5.3	43	5×5.3	50	6.3×5.3	65	6.3×7.7	94				5×5.3	41	5×5.3	44	6.3×5.3	58	6.3×5.3	64	6.3×5.8	67	8×6.2	95	47	4×5.3	35	4×5.3	36	5×5.3	47	5×5.3	52	6.3×5.3	70	6.3×7.7	94	6.3×7.7	105				5×5.3	48	6.3×5.3	62	6.3×5.3	69	6.3×5.8	72	8×6.2	105	8×10	140	100	5×5.3	54	5×5.3	60	6.3×5.3	80	6.3×5.3	88	8×6.2	145	6.3×7.7	132	8×10	181		6.3×5.3	68	6.3×5.3	82	6.3×5.8	82	6.3×5.8	91			8×10	175	10×10	195	220	6.3×5.3	93	6.3×5.8	91	6.3×7.7	173	6.3×7.7	162	8×10	232	10×10	265	10×10	320				8×6.2	175	8×10	215	8×10	215	10×10	250					330			6.3×7.7	188	8×10	240	8×10	270	10×10	305	10×10	360	12.5×13.5	600				8×6.2	190											470			8×10	265	8×10	290	8×10	307	10×10	400	12.5×13.5	600										10×10	330							1000			8×10	370	10×10	454	12.5×13.5	710	12.5×13.5	820								10×10	400											1500			10×10	480	12.5×13.5	850	12.5×13.5	870							2200			12.5×13.5	890	12.5×13.5	960								
													5×5.3	25																																																																																																																																																																																																																																																																																																																											
10	4×5.3	16	4×5.3	19	4×5.3	21	4×5.3	21	4×5.3	24	4×5.3	27	5×5.3	41										5×5.3	30	5×5.3	32	6.3×5.3	43	22	4×5.3	24	4×5.3	29	4×5.3	28	4×5.3	30	5×5.3	41	6.3×5.3	53	6.3×5.3	55						5×5.3	36	5×5.3	41	6.3×5.3	53			6.3×5.8	73	33	4×5.3	29	4×5.3	30	4×5.3	34	5×5.3	43	5×5.3	50	6.3×5.3	65	6.3×7.7	94				5×5.3	41	5×5.3	44	6.3×5.3	58	6.3×5.3	64	6.3×5.8	67	8×6.2	95	47	4×5.3	35	4×5.3	36	5×5.3	47	5×5.3	52	6.3×5.3	70	6.3×7.7	94	6.3×7.7	105				5×5.3	48	6.3×5.3	62	6.3×5.3	69	6.3×5.8	72	8×6.2	105	8×10	140	100	5×5.3	54	5×5.3	60	6.3×5.3	80	6.3×5.3	88	8×6.2	145	6.3×7.7	132	8×10	181		6.3×5.3	68	6.3×5.3	82	6.3×5.8	82	6.3×5.8	91			8×10	175	10×10	195	220	6.3×5.3	93	6.3×5.8	91	6.3×7.7	173	6.3×7.7	162	8×10	232	10×10	265	10×10	320				8×6.2	175	8×10	215	8×10	215	10×10	250					330			6.3×7.7	188	8×10	240	8×10	270	10×10	305	10×10	360	12.5×13.5	600				8×6.2	190											470			8×10	265	8×10	290	8×10	307	10×10	400	12.5×13.5	600										10×10	330							1000			8×10	370	10×10	454	12.5×13.5	710	12.5×13.5	820								10×10	400											1500			10×10	480	12.5×13.5	850	12.5×13.5	870							2200			12.5×13.5	890	12.5×13.5	960																																						
									5×5.3	30	5×5.3	32	6.3×5.3	43																																																																																																																																																																																																																																																																																																																											
22	4×5.3	24	4×5.3	29	4×5.3	28	4×5.3	30	5×5.3	41	6.3×5.3	53	6.3×5.3	55						5×5.3	36	5×5.3	41	6.3×5.3	53			6.3×5.8	73	33	4×5.3	29	4×5.3	30	4×5.3	34	5×5.3	43	5×5.3	50	6.3×5.3	65	6.3×7.7	94				5×5.3	41	5×5.3	44	6.3×5.3	58	6.3×5.3	64	6.3×5.8	67	8×6.2	95	47	4×5.3	35	4×5.3	36	5×5.3	47	5×5.3	52	6.3×5.3	70	6.3×7.7	94	6.3×7.7	105				5×5.3	48	6.3×5.3	62	6.3×5.3	69	6.3×5.8	72	8×6.2	105	8×10	140	100	5×5.3	54	5×5.3	60	6.3×5.3	80	6.3×5.3	88	8×6.2	145	6.3×7.7	132	8×10	181		6.3×5.3	68	6.3×5.3	82	6.3×5.8	82	6.3×5.8	91			8×10	175	10×10	195	220	6.3×5.3	93	6.3×5.8	91	6.3×7.7	173	6.3×7.7	162	8×10	232	10×10	265	10×10	320				8×6.2	175	8×10	215	8×10	215	10×10	250					330			6.3×7.7	188	8×10	240	8×10	270	10×10	305	10×10	360	12.5×13.5	600				8×6.2	190											470			8×10	265	8×10	290	8×10	307	10×10	400	12.5×13.5	600										10×10	330							1000			8×10	370	10×10	454	12.5×13.5	710	12.5×13.5	820								10×10	400											1500			10×10	480	12.5×13.5	850	12.5×13.5	870							2200			12.5×13.5	890	12.5×13.5	960																																																																				
					5×5.3	36	5×5.3	41	6.3×5.3	53			6.3×5.8	73																																																																																																																																																																																																																																																																																																																											
33	4×5.3	29	4×5.3	30	4×5.3	34	5×5.3	43	5×5.3	50	6.3×5.3	65	6.3×7.7	94				5×5.3	41	5×5.3	44	6.3×5.3	58	6.3×5.3	64	6.3×5.8	67	8×6.2	95	47	4×5.3	35	4×5.3	36	5×5.3	47	5×5.3	52	6.3×5.3	70	6.3×7.7	94	6.3×7.7	105				5×5.3	48	6.3×5.3	62	6.3×5.3	69	6.3×5.8	72	8×6.2	105	8×10	140	100	5×5.3	54	5×5.3	60	6.3×5.3	80	6.3×5.3	88	8×6.2	145	6.3×7.7	132	8×10	181		6.3×5.3	68	6.3×5.3	82	6.3×5.8	82	6.3×5.8	91			8×10	175	10×10	195	220	6.3×5.3	93	6.3×5.8	91	6.3×7.7	173	6.3×7.7	162	8×10	232	10×10	265	10×10	320				8×6.2	175	8×10	215	8×10	215	10×10	250					330			6.3×7.7	188	8×10	240	8×10	270	10×10	305	10×10	360	12.5×13.5	600				8×6.2	190											470			8×10	265	8×10	290	8×10	307	10×10	400	12.5×13.5	600										10×10	330							1000			8×10	370	10×10	454	12.5×13.5	710	12.5×13.5	820								10×10	400											1500			10×10	480	12.5×13.5	850	12.5×13.5	870							2200			12.5×13.5	890	12.5×13.5	960																																																																																																		
			5×5.3	41	5×5.3	44	6.3×5.3	58	6.3×5.3	64	6.3×5.8	67	8×6.2	95																																																																																																																																																																																																																																																																																																																											
47	4×5.3	35	4×5.3	36	5×5.3	47	5×5.3	52	6.3×5.3	70	6.3×7.7	94	6.3×7.7	105				5×5.3	48	6.3×5.3	62	6.3×5.3	69	6.3×5.8	72	8×6.2	105	8×10	140	100	5×5.3	54	5×5.3	60	6.3×5.3	80	6.3×5.3	88	8×6.2	145	6.3×7.7	132	8×10	181		6.3×5.3	68	6.3×5.3	82	6.3×5.8	82	6.3×5.8	91			8×10	175	10×10	195	220	6.3×5.3	93	6.3×5.8	91	6.3×7.7	173	6.3×7.7	162	8×10	232	10×10	265	10×10	320				8×6.2	175	8×10	215	8×10	215	10×10	250					330			6.3×7.7	188	8×10	240	8×10	270	10×10	305	10×10	360	12.5×13.5	600				8×6.2	190											470			8×10	265	8×10	290	8×10	307	10×10	400	12.5×13.5	600										10×10	330							1000			8×10	370	10×10	454	12.5×13.5	710	12.5×13.5	820								10×10	400											1500			10×10	480	12.5×13.5	850	12.5×13.5	870							2200			12.5×13.5	890	12.5×13.5	960																																																																																																																																
			5×5.3	48	6.3×5.3	62	6.3×5.3	69	6.3×5.8	72	8×6.2	105	8×10	140																																																																																																																																																																																																																																																																																																																											
100	5×5.3	54	5×5.3	60	6.3×5.3	80	6.3×5.3	88	8×6.2	145	6.3×7.7	132	8×10	181		6.3×5.3	68	6.3×5.3	82	6.3×5.8	82	6.3×5.8	91			8×10	175	10×10	195	220	6.3×5.3	93	6.3×5.8	91	6.3×7.7	173	6.3×7.7	162	8×10	232	10×10	265	10×10	320				8×6.2	175	8×10	215	8×10	215	10×10	250					330			6.3×7.7	188	8×10	240	8×10	270	10×10	305	10×10	360	12.5×13.5	600				8×6.2	190											470			8×10	265	8×10	290	8×10	307	10×10	400	12.5×13.5	600										10×10	330							1000			8×10	370	10×10	454	12.5×13.5	710	12.5×13.5	820								10×10	400											1500			10×10	480	12.5×13.5	850	12.5×13.5	870							2200			12.5×13.5	890	12.5×13.5	960																																																																																																																																																														
	6.3×5.3	68	6.3×5.3	82	6.3×5.8	82	6.3×5.8	91			8×10	175	10×10	195																																																																																																																																																																																																																																																																																																																											
220	6.3×5.3	93	6.3×5.8	91	6.3×7.7	173	6.3×7.7	162	8×10	232	10×10	265	10×10	320				8×6.2	175	8×10	215	8×10	215	10×10	250					330			6.3×7.7	188	8×10	240	8×10	270	10×10	305	10×10	360	12.5×13.5	600				8×6.2	190											470			8×10	265	8×10	290	8×10	307	10×10	400	12.5×13.5	600										10×10	330							1000			8×10	370	10×10	454	12.5×13.5	710	12.5×13.5	820								10×10	400											1500			10×10	480	12.5×13.5	850	12.5×13.5	870							2200			12.5×13.5	890	12.5×13.5	960																																																																																																																																																																																												
			8×6.2	175	8×10	215	8×10	215	10×10	250																																																																																																																																																																																																																																																																																																																															
330			6.3×7.7	188	8×10	240	8×10	270	10×10	305	10×10	360	12.5×13.5	600				8×6.2	190											470			8×10	265	8×10	290	8×10	307	10×10	400	12.5×13.5	600										10×10	330							1000			8×10	370	10×10	454	12.5×13.5	710	12.5×13.5	820								10×10	400											1500			10×10	480	12.5×13.5	850	12.5×13.5	870							2200			12.5×13.5	890	12.5×13.5	960																																																																																																																																																																																																																										
			8×6.2	190																																																																																																																																																																																																																																																																																																																																					
470			8×10	265	8×10	290	8×10	307	10×10	400	12.5×13.5	600										10×10	330							1000			8×10	370	10×10	454	12.5×13.5	710	12.5×13.5	820								10×10	400											1500			10×10	480	12.5×13.5	850	12.5×13.5	870							2200			12.5×13.5	890	12.5×13.5	960																																																																																																																																																																																																																																																								
							10×10	330																																																																																																																																																																																																																																																																																																																																	
1000			8×10	370	10×10	454	12.5×13.5	710	12.5×13.5	820								10×10	400											1500			10×10	480	12.5×13.5	850	12.5×13.5	870							2200			12.5×13.5	890	12.5×13.5	960																																																																																																																																																																																																																																																																																						
			10×10	400																																																																																																																																																																																																																																																																																																																																					
1500			10×10	480	12.5×13.5	850	12.5×13.5	870																																																																																																																																																																																																																																																																																																																																	
2200			12.5×13.5	890	12.5×13.5	960																																																																																																																																																																																																																																																																																																																																			

↑ ↑  
 Ripple current (mA rms) at 85°C, 120Hz  
 Case size  $\varnothing D \times L$  (mm)

$\mu\text{F}$ \diagdown WV	63		100		160		200		250		400		450																																																																																																																									
2.2													10×10	85																																																																																																																								
3.3			6.3×5.8	29							10×10	90	10×10	100																																																																																																																								
4.7	6.3×5.8	31	6.3×5.8	35			10×10	100	10×10	100	12.5×13.5	115	12.5×13.5	115				8×6.2	40											10	6.3×5.8	46	8×10	77	10×10	100	12.5×13.5	150	12.5×13.5	150					22	8×6.2	96	8×10	100	12.5×13.5	240	12.5×13.5	260							33	8×10	117	10×10	130	12.5×13.5	260									47	10×10	140	10×10	155											68	10×10	160	12.5×13.5	350											100	12.5×13.5	370	12.5×13.5	420											220	12.5×13.5	550												
			8×6.2	40																																																																																																																																		
10	6.3×5.8	46	8×10	77	10×10	100	12.5×13.5	150	12.5×13.5	150																																																																																																																												
22	8×6.2	96	8×10	100	12.5×13.5	240	12.5×13.5	260																																																																																																																														
33	8×10	117	10×10	130	12.5×13.5	260																																																																																																																																
47	10×10	140	10×10	155																																																																																																																																		
68	10×10	160	12.5×13.5	350																																																																																																																																		
100	12.5×13.5	370	12.5×13.5	420																																																																																																																																		
220	12.5×13.5	550																																																																																																																																				

↑ ↑  
 Ripple current (mA rms) at 85°C, 120Hz  
 Case size  $\varnothing D \times L$  (mm)

### ● FREQUENCY COEFFICIENT OF PERMISSIBLE RIPPLE CURRENT

Frequency	50Hz	120Hz	300Hz	1kHz	10kHz $\leq$
Coefficient	0.70	1.00	1.17	1.36	1.50



# SURFACE MOUNT ALUMINUM ELECTROLYTIC CAPACITORS

**RC** Chip type, Wide Temperature Range Series

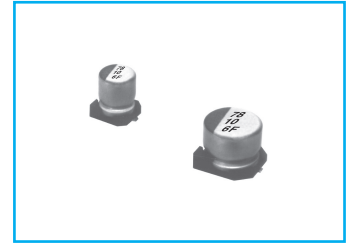

- Wide operating temperature range of -55 ~ +105°C
- Designed for surface mounting on high density PC board
- Applicable to automatic insertion machine using carrier tape
- Complied to the RoHS directive
- AEC-Q200 compliant : Please contact us for more details.

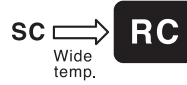

Item	Characteristics																					
Operating temperature range	-55 ~ +105°C																					
Leakage current max.	$I = 0.01CV$ or $3\mu A$ whichever is greater (after 2 minutes)																					
Capacitance tolerance	$\pm 20\%$ at 120Hz, 20°C																					
Dissipation factor max. (at 120Hz, 20°C)	<table border="1"> <tr> <td>WV</td> <td>6.3</td> <td>10</td> <td>16</td> <td>25</td> <td>35</td> <td>50</td> </tr> <tr> <td>tan<math>\delta</math></td> <td>0.27</td> <td>0.23</td> <td>0.19</td> <td>0.15</td> <td>0.13</td> <td>0.11</td> </tr> </table>	WV	6.3	10	16	25	35	50	tan $\delta$	0.27	0.23	0.19	0.15	0.13	0.11							
	WV	6.3	10	16	25	35	50															
tan $\delta$	0.27	0.23	0.19	0.15	0.13	0.11																
Low temperature characteristics (Impedance ratio at 120Hz)	<table border="1"> <tr> <td>WV</td> <td>6.3</td> <td>10</td> <td>16</td> <td>25</td> <td>35</td> <td>50</td> </tr> <tr> <td>Z-25°C/Z+20°C</td> <td>3</td> <td>3</td> <td>2</td> <td>2</td> <td>2</td> <td>2</td> </tr> <tr> <td>Z-55°C/Z+20°C</td> <td>8</td> <td>5</td> <td>4</td> <td>3</td> <td>3</td> <td>3</td> </tr> </table>	WV	6.3	10	16	25	35	50	Z-25°C/Z+20°C	3	3	2	2	2	2	Z-55°C/Z+20°C	8	5	4	3	3	3
	WV	6.3	10	16	25	35	50															
	Z-25°C/Z+20°C	3	3	2	2	2	2															
Z-55°C/Z+20°C	8	5	4	3	3	3																
Load life (after application of the rated voltage for 1000 hours at 105°C)	Leakage current	Less than specified value																				
	Capacitance change	Within $\pm 25\%$ of initial value																				
	tan $\delta$	Less than 200% of specified value																				
Shelf life (at 105°C)	After 1000 hours no load test, leakage current, capacitance and tan $\delta$ are same as load life value. The measurement shall be performed at 20°C by the KS C IEC 60384 - 4																					
Resistance to soldering heat	The following specifications shall be satisfied when the capacitors are restored to 20°C after exposing them at 250°C for 10 seconds.																					
	Leakage current	Less than specified value																				
	Capacitance change	Within $\pm 10\%$ of initial value																				
	tan $\delta$	Less than specified value																				

● DRAWING (See page 58)

-Series code of RC is "F"

● DIMENSIONS & MAXIMUM PERMISSIBLE RIPPLE CURRENT

$\mu F$ \ WV	6.3	10	16	25	35	50
1.0						4×5.3 7
2.2						4×5.3 11
3.3						4×5.3 13
4.7				4×5.3 13	4×5.3 14	5×5.3 18
10			4×5.3 17	5×5.3 23	5×5.3 24	6.3×5.3 31
22	4×5.3 22	5×5.3 27	5×5.3 30	6.3×5.3 39	6.3×5.3 42	6.3×5.8 45
33	5×5.3 31	5×5.3 33	6.3×5.3 43	6.3×5.3 48	6.3×5.8 52	6.3×7.7 60
47	5×5.3 36	6.3×5.3 46	6.3×5.3 51	6.3×5.8 59	6.3×5.8 63	6.3×7.7 63
100	6.3×5.3 50	6.3×5.8 64	6.3×5.8 64	6.3×7.7 91	8×10 296	10×10 295
220	6.3×7.7 86	6.3×7.7 105	6.3×7.7 105	8×10 340	10×10 435	
330	6.3×7.7 105	8×10 305	8×10 340	10×10 360		
470	8×10 330	10×10 340	10×10 470			
1000	10×10 475					

Ripple current (mA rms) at 105°C, 120Hz  
 Case size  $\varnothing D \times L$  (mm)

● FREQUENCY COEFFICIENT OF PERMISSIBLE RIPPLE CURRENT

Frequency	50Hz	120Hz	300Hz	1kHz	10kHz $\leq$
Coefficient	0.70	1.00	1.17	1.36	1.50

# SURFACE MOUNT ALUMINUM ELECTROLYTIC CAPACITORS



## JH Chip type, High Ripple Current Series



- High Ripple current Compared with JC series
- Designed for surface mounting on high density PC board
- Applicable to automatic insertion machine using carrier tape
- Complied to the RoHS directive
- AEC-Q200 compliant : Please contact us for more details.



Item	Characteristics																																
Operating temperature range	WV ≤ 100 : -55 ~ +105°C    WV ≥ 160 : -40 ~ +105°C																																
Leakage current max.	WV ≤ 100    I = 0.01CV or 3μA whichever is greater (after 2 minutes) WV ≥ 160    I = 0.04CV + 100μA(after 1 minutes)																																
Capacitance tolerance	± 20% at 120Hz, 20°C																																
Dissipation factor max. (at 120Hz, 20°C)	<table border="1"> <tr> <td>WV</td> <td>6.3</td> <td>10</td> <td>16</td> <td>25</td> <td>35</td> <td>50</td> <td>63</td> <td>100</td> <td>160</td> <td>200</td> <td>250</td> <td>400</td> </tr> <tr> <td>tanδ</td> <td>0.28</td> <td>0.24</td> <td>0.20</td> <td>0.16</td> <td>0.13</td> <td>0.12</td> <td>0.10</td> <td>0.10</td> <td>0.15</td> <td>0.15</td> <td>0.15</td> <td>0.20</td> </tr> </table>	WV	6.3	10	16	25	35	50	63	100	160	200	250	400	tanδ	0.28	0.24	0.20	0.16	0.13	0.12	0.10	0.10	0.15	0.15	0.15	0.20						
WV	6.3	10	16	25	35	50	63	100	160	200	250	400																					
tanδ	0.28	0.24	0.20	0.16	0.13	0.12	0.10	0.10	0.15	0.15	0.15	0.20																					
Low temperature characteristics (Impedance ratio at 120Hz)	<table border="1"> <tr> <td>WV</td> <td>6.3</td> <td>10</td> <td>16</td> <td>25 ~ 50</td> <td>63 ~ 100</td> <td>160 ~ 250</td> <td>400</td> </tr> <tr> <td>Z-25°C/Z+20°C</td> <td>3</td> <td>3</td> <td>2</td> <td>2</td> <td>3</td> <td>3</td> <td>6</td> </tr> <tr> <td>Z-40°C/Z+20°C</td> <td>-</td> <td>-</td> <td>-</td> <td>-</td> <td>-</td> <td>6</td> <td>10</td> </tr> <tr> <td>Z-55°C/Z+20°C</td> <td>8</td> <td>5</td> <td>4</td> <td>3</td> <td>4</td> <td>-</td> <td>-</td> </tr> </table>	WV	6.3	10	16	25 ~ 50	63 ~ 100	160 ~ 250	400	Z-25°C/Z+20°C	3	3	2	2	3	3	6	Z-40°C/Z+20°C	-	-	-	-	-	6	10	Z-55°C/Z+20°C	8	5	4	3	4	-	-
WV	6.3	10	16	25 ~ 50	63 ~ 100	160 ~ 250	400																										
Z-25°C/Z+20°C	3	3	2	2	3	3	6																										
Z-40°C/Z+20°C	-	-	-	-	-	6	10																										
Z-55°C/Z+20°C	8	5	4	3	4	-	-																										
Load life (after application of the rated voltage for 2000 hours at 105°C)	<table border="1"> <tr> <td>Leakage current</td> <td>Less than specified value</td> </tr> <tr> <td>Capacitance change</td> <td>Within ±20% of initial value</td> </tr> <tr> <td>tanδ</td> <td>Less than 200% of specified value</td> </tr> </table>	Leakage current	Less than specified value	Capacitance change	Within ±20% of initial value	tanδ	Less than 200% of specified value																										
Leakage current	Less than specified value																																
Capacitance change	Within ±20% of initial value																																
tanδ	Less than 200% of specified value																																
Shelf life (at 105°C)	After 1000 hours no load test, leakage current, capacitance and tanδ are same as load life value. The measurement shall be performed at 20°C by the KS C IEC 60384 - 4																																
Resistance to soldering heat	<p>The following specifications shall be satisfied when the capacitors are restored to 20°C after exposing them at 250°C for 10 seconds.</p> <table border="1"> <tr> <td>Leakage current</td> <td>Less than specified value</td> </tr> <tr> <td>Capacitance change</td> <td>Within ±10% of initial value</td> </tr> <tr> <td>tanδ</td> <td>Less than specified value</td> </tr> </table>	Leakage current	Less than specified value	Capacitance change	Within ±10% of initial value	tanδ	Less than specified value																										
Leakage current	Less than specified value																																
Capacitance change	Within ±10% of initial value																																
tanδ	Less than specified value																																

### ● DRAWING -Series code of JH is "G"

Unit : mm

CHIP TYPES

(∅6.3, ∅8×6.2)

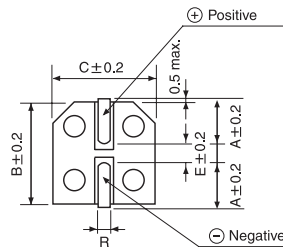
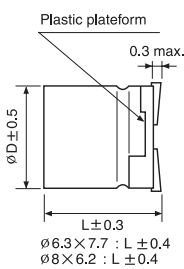
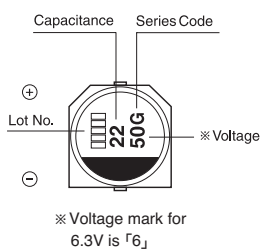

∅D×L	A	B	C	E	R
6.3×5.8	2.4	6.6	6.6	2.2	0.5~0.8
6.3×7.7	2.4	6.6	6.6	2.2	0.5~0.8
8×6.2	3.3	8.3	8.3	2.3	0.5~0.8
8×10	2.9	8.3	8.3	3.1	0.8~1.1
10×10	3.2	10.3	10.3	4.5	0.8~1.1
12.5×13.5	4.6	12.8	12.8	4.5	1.3~1.6

(∅8×10, ∅10×10)

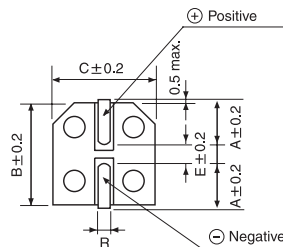
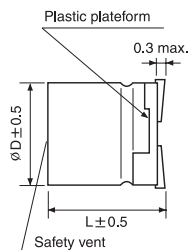
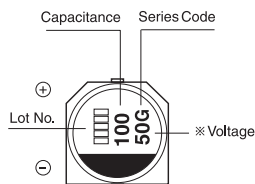

(∅12.5)

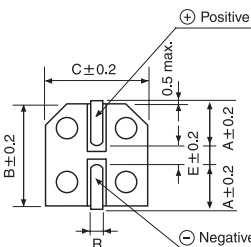
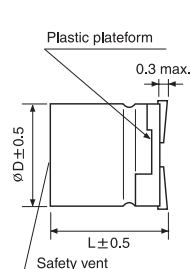
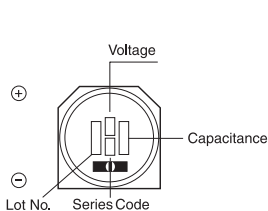

# SURFACE MOUNT ALUMINUM ELECTROLYTIC CAPACITORS

**JH** series

## ● DIMENSIONS & MAXIMUM PERMISSIBLE RIPPLE CURRENT

$\mu\text{F}$ \diagdown WV	6.3		10		16		25		35	
22							6.3×5.8	57	6.3×5.8	63
33					6.3×5.8	60	6.3×5.8	72	8×6.2	114
47			6.3×5.8	69	6.3×5.8	75	8×6.2	120	8×10	186
100	6.3×5.8	90	6.3×5.8	90	6.3×5.8	110	8×10	270	10×10	456
					8×10	222				
220	8×10	242	8×10	260	10×10	495	10×10	525	10×10	675
330	8×10	432	10×10	477	10×10	660	10×10	558	12.5×13.5	750
470	10×10	510	10×10	527	10×10	735	10×10	675	12.5×13.5	900
680	10×10	612	10×10	588	12.5×13.5	750	12.5×13.5	750		
1000	10×10	743	10×10	825	12.5×13.5	900				
1500	10×10	840	12.5×13.5	975						
2200	12.5×13.5	1095								

$\mu\text{F}$ \diagdown WV	50		63		100	
10	6.3×5.8	45	8×6.2	48		
22	8×6.2	100	8×10	90	8×10	135
33	8×10	200	8×10	165	10×10	180
			10×10	175		
47	10×10	270	10×10	195	10×10	285
					12.5×13.5	375
68	10×10	315	10×10	240	12.5×13.5	450
100	10×10	465	12.5×13.5	405		
220	12.5×13.5	720				

$\mu\text{F}$ \diagdown WV	160		200		250		400	
3.3					10×10	45	12.5×13.5	45
4.7			10×10	65	12.5×13.5	95		
10	10×10	65	12.5×13.5	110				
22	12.5×13.5	125	12.5×13.5	125				
33	12.5×13.5	140						

↑ Ripple current (mA rms) at 105°C, 120Hz  
 ↑ Case size  $\varnothing D \times L$  (mm)

## ● FREQUENCY COEFFICIENT OF PERMISSIBLE RIPPLE CURRENT

Frequency	50Hz	120Hz	300Hz	1kHz	10kHz $\leq$
Coefficient	0.70	1.00	1.17	1.36	1.50

# SURFACE MOUNT ALUMINUM ELECTROLYTIC CAPACITORS



## JM Chip type, Long Life Series

- Long Life Compared with JC series
- Designed for surface mounting on high density PC board
- Applicable to automatic insertion machine using carrier tape
- Complied to the RoHS directive
- AEC-Q200 compliant : Please contact us for more details.

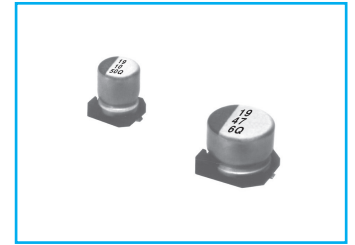

Item	Characteristics												
Operating temperature range	-40 ~ +105°C												
Leakage current max.	WV ≤ 100 I = 0.01CV or 3μA whichever is greater (after 2 minutes) WV ≥ 160 I = 0.04CV + 100μA(after 1 minutes)												
Capacitance tolerance	±20% at 120Hz, 20°C												
Dissipation factor max. (at 120Hz, 20°C)	WV	6.3	10	16	25	35	50	63	100	160	200	250	400
	tanδ	0.32	0.28	0.21	0.21	0.18	0.18	0.12	0.12	0.15	0.15	0.15	0.20
Low temperature characteristics (Impedance ratio at 120Hz)	WV	6.3	10	16	25 ~ 50	63 ~ 100	160 ~ 250	400					
	Z-25°C/Z+20°C	3	3	3	3	3	3	6					
	Z-40°C/Z+20°C	8	5	4	3	4	6	10					
Load life (after application of the rated voltage for 3000 hours at 105°C)	Leakage current	Less than specified value											
	Capacitance change	Within ±30% of initial value											
	tanδ	Less than 300% of specified value											
Shelf life (at 105°C)	After 1000 hours no load test, leakage current, capacitance and tanδ are same as load life value. The measurement shall be performed at 20°C by the KS C IEC 60384 - 4												
Resistance to soldering heat	The following specifications shall be satisfied when the capacitors are restored to 20°C after exposing them at 250°C for 10 seconds.												
	Leakage current	Less than specified value											
	Capacitance change	Within ±10% of initial value											
	tanδ	Less than specified value											

### ● DRAWING -Series code of JM is "Q"

Unit : mm

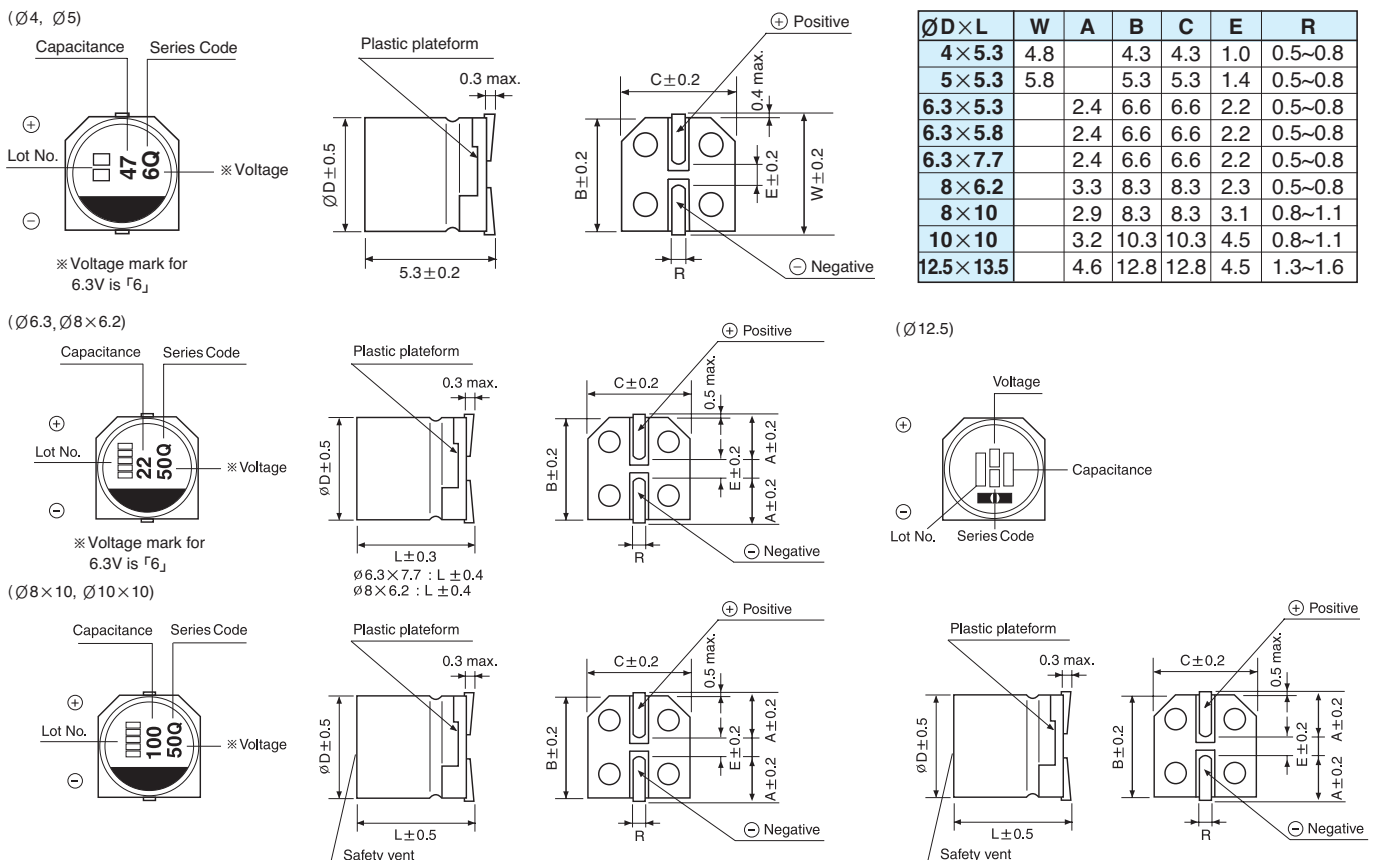

# SURFACE MOUNT ALUMINUM ELECTROLYTIC CAPACITORS

**JM** series

## ● DIMENSIONS & MAXIMUM PERMISSIBLE RIPPLE CURRENT

$\mu\text{F}$ \diagdown WV	6.3		10		16		25		35	
10	4×5.3	10	4×5.3	15	4×5.3	19	5×5.3	24	6.3×5.3	26
22	4×5.3	25	5×5.3	30	5×5.3	33	6.3×5.3	38	6.3×5.8	42
33	5×5.3	35	5×5.3	38	6.3×5.3	42	6.3×5.8	48	8×6.2	76
47	5×5.3	42	6.3×5.3	52	6.3×5.8	60	8×6.2	79	8×10	124
100	6.3×5.8	60	6.3×5.8	60	8×10	148	8×10	181	10×10	310
220	8×10	161	8×10	173	10×10	330	10×10	351	10×10	480
330	8×10	288	10×10	318	10×10	441	10×10	372	12.5×13.5	500
470	10×10	340	10×10	351	10×10	489	10×10	450	12.5×13.5	600
680	10×10	408	10×10	392	12.5×13.5	500	12.5×13.5	500		
1000	10×10	495	10×10	550	12.5×13.5	600				
1500	10×10	560	12.5×13.5	650						
2200	12.5×13.5	730								

$\mu\text{F}$ \diagdown WV	50		63		100	
10	6.3×5.8	30	8×6.2	32		
22	8×6.2	67	8×10	60	8×10	90
33	8×10	133	8×10	110	10×10	120
47	10×10	180	10×10	130	12.5×13.5	250
68	10×10	200	10×10	160	12.5×13.5	300
100	10×10	310	12.5×13.5	270		
220	12.5×13.5	480				

$\mu\text{F}$ \diagdown WV	160		200		250		400	
2.2							8×10	27
3.3					10×10	30	12.5×13.5	30
4.7			10×10	45	12.5×13.5	65	12.5×13.5	40
6.8								
10	10×10	45	12.5×13.5	75				
22	12.5×13.5	85	12.5×13.5	85				
33	12.5×13.5	95						

↑ Ripple current (mA rms) at 105°C, 120Hz  
 ↑ Case size  $\varnothing D \times L$  (mm)

## ● FREQUENCY COEFFICIENT OF PERMISSIBLE RIPPLE CURRENT

Frequency	50Hz	120Hz	300Hz	1kHz	10kHz $\leq$
Coefficient	0.70	1.00	1.17	1.36	1.50

## CA Chip type, Long Life Series

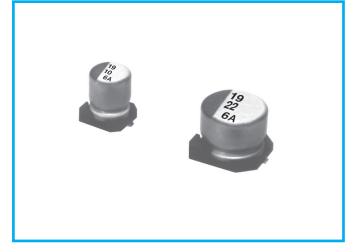
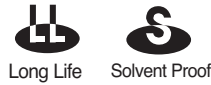

- Chip type, long life capacitance in large case sizes
- Chip type with load life of 5000 hours at 105°C
- Designed for surface mounting on high density PC board
- Applicable to automatic insertion machine using carrier tape
- Complied to the RoHS directive
- AEC-Q200 compliant : Please contact us for more details.

Item	Characteristics						
Operating temperature range	$\varnothing D \leq 6.3$			$\varnothing D \geq 8$			
	-40 ~ +105°C			-55 ~ +105°C			
Leakage current max.	I = 0.01CV or 3 $\mu$ A whichever is greater (after 2 minutes)						
Capacitance tolerance	±20% at 120Hz, 20°C						
Dissipation factor max. (at 120Hz, 20°C)	WV	6.3	10	16	25	35	50
	tan $\delta$	0.28	0.24	0.2	0.16	0.13	0.12
Low temperature characteristics (Impedance ratio at 120Hz)	WV	6.3	10	16	25	35	50
	Z-25°C/Z+20°C	2	2	2	3	3	3
	Z-55°C/Z+20°C	14	12	8	6	4	4
	Z-40°C/Z+20°C	14	12	8	6	4	4
Load life (after application of the rated voltage for 5000 hours at 105°C)	Leakage current	Less than specified value					
	Capacitance change	Within ±30% of initial value					
	tan $\delta$	Less than 300% of specified value					
Shelf life (at 105°C)	After 1000 hours no load test, leakage current, capacitance and tan $\delta$ are same as load life value. The measurement shall be performed at 20°C by the KS C IEC 60384 - 4						
Resistance to soldering heat	The following specifications shall be satisfied when the capacitors are restored to 20°C after exposing them at 250°C for 10 seconds.						
	Leakage current	Less than specified value					
	Capacitance change	Within ±10% of initial value					
	tan $\delta$	Less than specified value					

### ● DRAWING (See page 58)

-Series code of CA is "A"

### ● DIMENSIONS & MAXIMUM PERMISSIBLE RIPPLE CURRENT

$\mu$ F	WV	6.3		10		16		25		35		50	
10												6.3×5.8	30
22								6.3×5.8	38	6.3×5.8	42	6.3×7.7	120
33						6.3×5.8	40	6.3×5.8	48	6.3×7.7	57	8×10	140
47				6.3×5.8	46	6.3×5.8	50	6.3×7.7	63	8×10	92	8×10	170
100	6.3×5.8	60	6.3×7.7	81	6.3×7.7	81	8×10	116	10×10	151	10×10	310	
220	6.3×7.7	101	8×10	141	10×10	216	10×10	216	10×10	216			
330	8×10	160	10×10	238	10×10	238	10×10	238					
470	10×10	254	10×10	254	10×10	254							
1000	10×10	313											

← Ripple current (mA rms) at 105°C, 120Hz  
 ↑ Case size  $\varnothing D \times L$  (mm)

### ● FREQUENCY COEFFICIENT OF PERMISSIBLE RIPPLE CURRENT

Frequency	50Hz	120Hz	300Hz	1kHz	10kHz $\leq$
Coefficient	0.70	1.00	1.17	1.36	1.50

# SURFACE MOUNT ALUMINUM ELECTROLYTIC CAPACITORS

**CB** Chip type, Long Life Series

**LL** Long Life **S** Solvent Proof

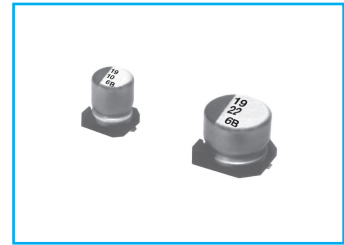

- Chip type with load life 5000 hours at 105°C
- Chip type with 5.5mmL Height
- Designed for surface mounting on high density PC board
- Applicable to automatic insertion machine using carrier tape
- Complied to the RoHS directive
- AEC-Q200 compliant : Please contact us for more details.

**RC** → **CB**  
Long life

Item	Characteristics																								
Operating temperature range	-40 ~ +105°C																								
Leakage current max.	$I = 0.01CV$ or $3\mu A$ whichever is greater (after 2 minutes)																								
Capacitance tolerance	$\pm 20\%$ at 120Hz, 20°C																								
Dissipation factor max. (at 120Hz, 20°C)	<table border="1"> <tr> <td>WV</td> <td>4</td> <td>6.3</td> <td>10</td> <td>16</td> <td>25</td> <td>35</td> <td>50</td> </tr> <tr> <td>tan<math>\delta</math></td> <td>0.32</td> <td>0.28</td> <td>0.24</td> <td>0.2</td> <td>0.16</td> <td>0.13</td> <td>0.12</td> </tr> </table>	WV	4	6.3	10	16	25	35	50	tan $\delta$	0.32	0.28	0.24	0.2	0.16	0.13	0.12								
	WV	4	6.3	10	16	25	35	50																	
tan $\delta$	0.32	0.28	0.24	0.2	0.16	0.13	0.12																		
Low temperature characteristics (Impedance ratio at 120Hz)	<table border="1"> <tr> <td>WV</td> <td>4</td> <td>6.3</td> <td>10</td> <td>16</td> <td>25</td> <td>35</td> <td>50</td> </tr> <tr> <td>Z-25°C/Z+20°C</td> <td>12</td> <td>10</td> <td>8</td> <td>6</td> <td>4</td> <td>4</td> <td>4</td> </tr> <tr> <td>Z-40°C/Z+20°C</td> <td>16</td> <td>14</td> <td>12</td> <td>8</td> <td>6</td> <td>6</td> <td>4</td> </tr> </table>	WV	4	6.3	10	16	25	35	50	Z-25°C/Z+20°C	12	10	8	6	4	4	4	Z-40°C/Z+20°C	16	14	12	8	6	6	4
	WV	4	6.3	10	16	25	35	50																	
	Z-25°C/Z+20°C	12	10	8	6	4	4	4																	
Z-40°C/Z+20°C	16	14	12	8	6	6	4																		
Load life (after application of the rated voltage for 5000 hours at 105°C)	<table border="1"> <tr> <td>Capacitance change</td> <td>Within <math>\pm 30\%</math> of initial value</td> </tr> <tr> <td>tan<math>\delta</math></td> <td>Less than 300% of the specified value</td> </tr> <tr> <td>Leakage current</td> <td>Less than specified value</td> </tr> </table>	Capacitance change	Within $\pm 30\%$ of initial value	tan $\delta$	Less than 300% of the specified value	Leakage current	Less than specified value																		
	Capacitance change	Within $\pm 30\%$ of initial value																							
	tan $\delta$	Less than 300% of the specified value																							
Leakage current	Less than specified value																								
Shelf life(at 105°C)	After 1000 hours no load test, leakage current, capacitance and tan $\delta$ are same as load life value. The measurement shall be performed at 20°C by the KS C IEC 60384 - 4																								
Resistance to soldering heat	<p>The following specifications shall be satisfied when the capacitors are restored to 20°C after exposing them at 250°C for 10 seconds.</p> <table border="1"> <tr> <td>Leakage current</td> <td>Less than specified value</td> </tr> <tr> <td>Capacitance change</td> <td>Within <math>\pm 10\%</math> of initial value</td> </tr> <tr> <td>tan<math>\delta</math></td> <td>Less than specified value</td> </tr> </table>	Leakage current	Less than specified value	Capacitance change	Within $\pm 10\%$ of initial value	tan $\delta$	Less than specified value																		
	Leakage current	Less than specified value																							
	Capacitance change	Within $\pm 10\%$ of initial value																							
tan $\delta$	Less than specified value																								

## ● DRAWING (See page 58)

-Series code of CB is "B"

## ● DIMENSIONS & MAXIMUM PERMISSIBLE RIPPLE CURRENT

$\mu F$ \ WV	4		6.3		10		16		25		35		50	
1.0													4×5.3	7
2.2													4×5.3	11
3.3													4×5.3	14
4.7									4×5.3	14	4×5.3	15	5×5.3	19
6.8									4×5.3	17	5×5.3	21	6.3×5.3	26
10							4×5.3	19	5×5.3	24	5×5.3	26	6.3×5.3	33
15					4×5.3	22	5×5.3	28	5×5.3	31	6.3×5.3	37	6.3×5.3	40
22	4×5.3	24	4×5.3	25	5×5.3	30	5×5.3	33	6.3×5.3	42	6.3×5.3	45		
33	5×5.3	33	5×5.3	35	5×5.3	38	6.3×5.3	48						
47	5×5.3	40	5×5.3	42	6.3×5.3	52	6.3×5.3	57						
68	5×5.3	48	6.3×5.3	55	6.3×5.3	63								
100	5×5.3	55	6.3×5.3	67	6.3×5.3	72								

↑  
Ripple current (mA rms) at 105°C, 120Hz  
Case size  $\varnothing D \times L$ (mm)

## ● FREQUENCY COEFFICIENT OF PERMISSIBLE RIPPLE CURRENT

Frequency	50Hz	120Hz	300Hz	1kHz	10kHz $\leq$
Coefficient	0.70	1.00	1.17	1.36	1.50



## JL Chip type, Long Life Series

- Chip type, long life capacitance in large case sizes
- For ECU
- Application to automatic insertion machine using carrier tape
- Complied to the RoHS directive
- AEC-Q200 compliant : Please contact us for more details.

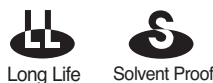

Item	Characteristics					
Operating temperature range	-40 ~ +105°C					
Leakage current	I = 0.03CV or 4μA whichever is greater (after 2 minutes)					
Capacitance tolerance	±20% (20°C, 120Hz)					
Dissipation factor max. (at 120Hz, 20°C)	WV	10	16	25	35	50
	tanδ	0.32	0.24	0.21	0.18	0.18
Low temperature characteristics (Impedance ratio at 120Hz)	WV	10	16	25	35	50
	Z-25°C/Z+20°C	6	4	3	2	2
	Z-40°C/Z+20°C	12	10	8	6	6
Load life (after application of the rated voltage for 10000 hours at 105°C)	Leakage current	Less than specified value				
	Capacitance change	Within ±30% of the initial value				
	tanδ	Less than 300% of the specified value				
Shelf life (at 105°C)	After 1000 hours no load test, leakage current, capacitance and tanδ are same as load life value. The measurement shall be performed at 20°C by the KS C IEC 60384 - 4					
Resistance to soldering heat	The following specifications shall be satisfied when the capacitors are restored to 20°C after exposing them at 250°C for 10 seconds.					
	Leakage current	Less than specified value				
	Capacitance change	Within ±10% of the initial value				
	tanδ	Less than specified value				

### ● DRAWING (See page 58)

-Series code of JL is "P"

### ● DIMENSIONS & MAXIMUM PERMISSIBLE RIPPLE CURRENT

μF \ WV	10		16		25		35		50	
33									8×10	75
47							8×10	90	8×10	90
100			8×10	270	8×10	163	10×10	132	10×10	167
220	8×10	270	8×10	270	10×10	200	10×10	249		
330	8×10	270	10×10	315	10×10	304				
470	10×10	315	10×10	315						

↑ ↑  
 — Ripple current (mA rms) at 105°C, 120Hz  
 — Case size ØD×L(mm)

### ● FREQUENCY COEFFICIENT OF PERMISSIBLE RIPPLE CURRENT

Frequency	50Hz	120Hz	300Hz	1kHz	10kHz≤
Coefficient	0.70	1.00	1.17	1.36	1.50

# SURFACE MOUNT ALUMINUM ELECTROLYTIC CAPACITORS

**ZC** Height 5.5mmL, Low Impedance Series



- Chip type, low impedance temperature range up to 105°C
- Designed for surface mounting on high density PC board
- Applicable to automatic insertion machine using carrier tape
- Complied to the RoHS directive
- AEC-Q200 compliant : Please contact us for more details.



Item	Characteristics																		
Operating temperature range	-55 ~ +105°C																		
Leakage current max.	$I = 0.01CV$ or $3\mu A$ whichever is greater (after 2 minutes)																		
Capacitance tolerance	$\pm 20\%$ at 120Hz, 20°C																		
Dissipation factor max. (at 120Hz, 20°C)	<table border="1"> <tr> <td>WV</td> <td>6.3</td> <td>10</td> <td>16</td> <td>25</td> <td>35</td> </tr> <tr> <td>tan<math>\delta</math></td> <td>0.22</td> <td>0.19</td> <td>0.16</td> <td>0.14</td> <td>0.12</td> </tr> </table>	WV	6.3	10	16	25	35	tan $\delta$	0.22	0.19	0.16	0.14	0.12						
	WV	6.3	10	16	25	35													
tan $\delta$	0.22	0.19	0.16	0.14	0.12														
Low temperature characteristics (Impedance ratio at 120Hz)	<table border="1"> <tr> <td>WV</td> <td>6.3</td> <td>10</td> <td>16</td> <td>25</td> <td>35</td> </tr> <tr> <td>Z-25°C/Z+20°C</td> <td>2</td> <td>2</td> <td>2</td> <td>2</td> <td>3</td> </tr> <tr> <td>Z-55°C/Z+20°C</td> <td>4</td> <td>4</td> <td>3</td> <td>3</td> <td>3</td> </tr> </table>	WV	6.3	10	16	25	35	Z-25°C/Z+20°C	2	2	2	2	3	Z-55°C/Z+20°C	4	4	3	3	3
	WV	6.3	10	16	25	35													
	Z-25°C/Z+20°C	2	2	2	2	3													
Z-55°C/Z+20°C	4	4	3	3	3														
Load life (after application of the rated voltage for 1000 hours at 105°C)	Leakage current	Less than specified value																	
	Capacitance change	Within $\pm 20\%$ of initial value																	
	tan $\delta$	Less than 200% of specified value																	
Shelf life (at 105°C)	After 1000 hours no load test, leakage current, capacitance and tan $\delta$ are same as load life value. The measurement shall be performed at 20°C by the KS C IEC 60384 - 4																		
Resistance to soldering heat	The following specifications shall be satisfied when the capacitors are restored to 20°C after exposing them at 250°C for 10 seconds.																		
	Leakage current	Less than specified value																	
	Capacitance change	Within $\pm 10\%$ of initial value																	
	tan $\delta$	Less than specified value																	

## ● DRAWING (See page 58)

-Series code of ZC is "Z"

## ● DIMENSIONS & MAXIMUM PERMISSIBLE RIPPLE CURRENT

$\mu F$ \ WV	6.3			10			16			25			35		
1.0													4×5.3	5.0	50
1.5													4×5.3	5.0	50
2.2													4×5.3	5.0	50
3.3													4×5.3	5.0	50
4.7										4×5.3	5.0	50	4×5.3	5.0	50
6.8										4×5.3	5.0	50	5×5.3	2.6	80
10							4×5.3	5.0	50	5×5.3	2.6	80	5×5.3	2.6	80
15							5×5.3	2.6	80	6.3×5.3	1.3	75	6.3×5.3	1.3	115
22	4×5.3	5.0	50	5×5.3	2.6	80	5×5.3	2.6	80	6.3×5.3	1.3	115	6.3×5.3	1.3	115
33	5×5.3	2.6	80	5×5.3	2.6	80	6.3×5.3	1.3	115	6.3×5.3	1.3	115	6.3×5.3	1.3	115
47	5×5.3	2.6	80	6.3×5.3	1.3	115	6.3×5.3	1.3	115	6.3×5.3	1.3	115	6.3×5.3	1.3	115
68	6.3×5.3	1.3	115	6.3×5.3	1.3	115	6.3×5.3	1.3	115	← Ripple current (mA rms) at 105°C, 100kHz					
100	6.3×5.3	1.3	115							← Impedance ( $\Omega$ ) at 20°C, 100kHz					
										← Case size $\varnothing D \times L$ (mm)					

## ● FREQUENCY COEFFICIENT OF PERMISSIBLE RIPPLE CURRENT

Frequency	50Hz	120Hz	300Hz	1kHz	10kHz $\leq$
Coefficient	0.35	0.5	0.64	0.83	1.00

# SURFACE MOUNT ALUMINUM ELECTROLYTIC CAPACITORS



## CD Chip type, Extremely Low Impedance Series

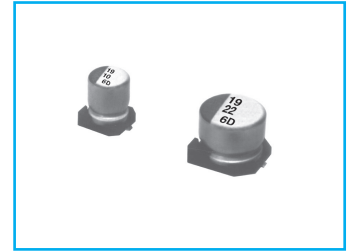

- Chip type, low impedance temperature range up to 105°C
- Designed for surface mounting on high density PC board
- Applicable to automatic insertion machine using carrier tape
- Complied to the RoHS directive
- AEC-Q200 compliant : Please contact us for more details.

Item	Characteristics									
Operating temperature range	-55 ~ +105°C									
Leakage current max.	$I = 0.01CV$ or $3\mu A$ whichever is greater (after 2 minutes)									
Capacitance tolerance	$\pm 20\%$ at 120Hz, 20°C									
Dissipation factor max. (at 120Hz, 20°C)	WV	6.3	10	16	25	35	50	63	80	100
	tan $\delta$	0.24	0.19	0.16	0.14	0.12	0.12	0.10	0.10	0.10
Low temperature characteristics (Impedance ratio at 120Hz)	WV	6.3	10	16	25	35	50	63~100		
	Z-25°C/Z+20°C	2	2	2	2	2	2	3		
	Z-55°C/Z+20°C	3	3	3	3	3	3	4		
Load life (after application of the rated voltage for 2000 hours at 105°C)	Leakage current	Less than specified value								
	Capacitance change	Within $\pm 25\%$ of initial value								
	tan $\delta$	Less than 200% of specified value								
Shelf life (at 105°C)	After 1000 hours no load test, leakage current, capacitance and tan $\delta$ are same as load life value. The measurement shall be performed at 20°C by the KS C IEC 60384 - 4									
Resistance to soldering heat	The following specifications shall be satisfied when the capacitors are restored to 20°C after exposing them at 250°C for 10 seconds.									
	Leakage current	Less than specified value								
	Capacitance change	Within $\pm 10\%$ of initial value								
	tan $\delta$	Less than specified value								

### DRAWING

Unit : mm

-Series code of CD is "D"

( $\varnothing 6.3 \times 5.8, 7.7, \varnothing 8 \times 6.2$ )

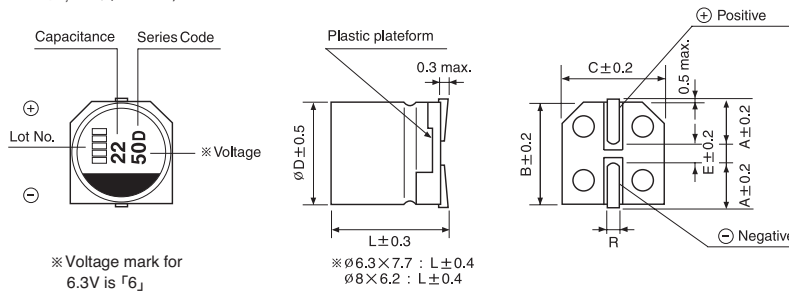

$\varnothing D$	A	B	C	E	R
6.3×5.8	2.4	6.6	6.6	2.2	0.5~0.8
6.3×7.7	2.4	6.6	6.6	2.2	0.5~0.8
8×6.2	3.3	8.3	8.3	2.3	0.5~0.8
8×10	2.9	8.3	8.3	3.1	0.8~1.1
10×10	3.2	10.3	10.3	4.5	0.8~1.1
12.5×13.5	4.6	12.8	12.8	4.5	1.3~1.6

( $\varnothing 8 \times 10, \varnothing 10 \times 10$ )

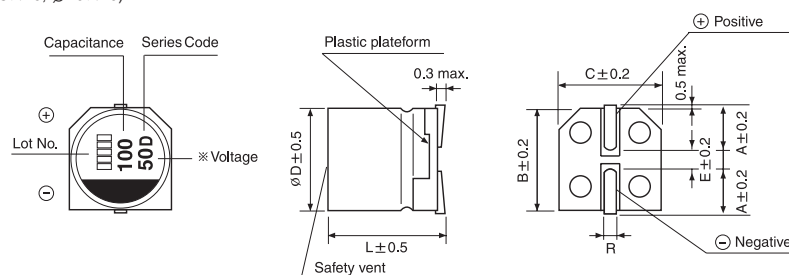

# SURFACE MOUNT ALUMINUM ELECTROLYTIC CAPACITORS

**CD** series

## ● DIMENSIONS & MAXIMUM PERMISSIBLE RIPPLE CURRENT

$\mu\text{F}$ \diagdown WV	6.3			10			16			25			35			50		
10																6.3×5.8	0.92	170
15																6.3×5.8	0.79	170
22																6.3×5.8	0.79	170
33							6.3×5.8	0.39	384	6.3×5.8	0.39	384	6.3×5.8	0.43	384	6.3×7.7	0.61	280
																8×6.2	0.58	300
47				6.3×5.8	0.36	384	5×5.3	1.00	210	6.3×5.8	0.39	384	6.3×5.3	0.70	240	6.3×7.7	0.61	280
							6.3×5.8	0.39	384				6.3×5.8	0.43	384	8×6.2	0.58	300
68	6.3×5.8	0.40	384	6.3×5.8	0.36	384	6.3×5.8	0.36	384	6.3×5.8	0.36	384	6.3×7.7	0.29	600	8×10	0.29	450
100	6.3×5.3	0.53	250	6.3×5.8	0.36	384	6.3×5.3	0.70	250	6.3×7.7	0.29	600	6.3×7.7	0.29	600	8×10	0.29	450
	6.3×5.8	0.40	384				6.3×5.8	0.36	384	8×6.2	0.24	500	8×10	0.15	960	10×10	0.18	700
150	6.3×5.8	0.40	384	6.3×5.8	0.36	384	6.3×5.8	0.36	384	8×10	0.15	960	8×10	0.15	960	10×10	0.18	700
							6.3×7.7	0.29	600									
220	6.3×5.8	0.40	384	6.3×7.7	0.32	600	6.3×7.7	0.29	600	6.3×7.7	0.29	600	8×10	0.15	960	10×10	0.18	700
				8×6.2	0.24	500	8×6.2	0.24	500	8×10	0.15	960	10×10	0.09	1360			
330	6.3×7.7	0.29	600	8×10	0.15	960	8×10	0.15	960	8×10	0.15	960	8×10	0.10	960			
	8×6.2	0.24	500				10×10	0.10	960	10×10	0.09	1360	10×10	0.09	1360			
470	8×10	0.15	960	6.3×7.7	0.16	600	8×10	0.16	960	8×10	0.15	960	10×10	0.09	1360			
				8×10	0.15	960	10×10	0.07	1360	10×10	0.09	1360						
560	8×10	0.15	960	8×10	0.15	960	10×10	0.07	1360	10×10	0.09	1360						
680	8×10	0.15	960	8×10	0.15	960	10×10	0.08	1360									
				10×10	0.07	1360												
820	8×10	0.15	960	10×10	0.08	1360												
1000	8×10	0.15	960	10×10	0.08	1360												
	10×10	0.07	1360															
1500	10×10	0.07	1360															

$\mu\text{F}$ \diagdown WV	63			80			100		
10	6.3×5.8	2.30	80	6.3×7.7	2.16	60			
22	6.3×7.7	1.90	120	8×10	1.17	130	8×10	1.80	130
33	8×10	0.80	250	8×10	1.17	130	10×10	1.35	200
47	8×10	0.80	250	10×10	1.08	200	12.5×13.5	0.90	500
68	10×10	0.70	400	12.5×13.5	0.70	500	12.5×13.5	0.90	500
100	10×10	0.70	400	12.5×13.5	0.70	500			
150	12.5×13.5	0.54	800	12.5×13.5	0.70	500			
220	12.5×13.5	0.54	800						

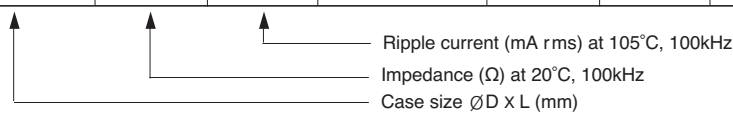

## ● FREQUENCY COEFFICIENT OF PERMISSIBLE RIPPLE CURRENT

Frequency	50Hz	120Hz	300Hz	1kHz	10kHz $\leq$
Coefficient	0.35	0.50	0.64	0.83	1.00

## CG Chip type, Miniaturization Series



- Chip type, miniaturized temperature range up to 105°C
- Applicable to automatic insertion machine using carrier tape
- Complied to the RoHS directive
- AEC-Q200 compliant : Please contact us for more details.

CD → **CG**  
miniaturized

Item	Characteristics						
Operating temperature range	-55 ~ +105°C						
Leakage current max.	$I = 0.01CV$ or $3\mu A$ whichever is greater (after 2 minutes)						
Capacitance tolerance	$\pm 20\%$ at 120Hz, 20°C						
Dissipation factor max. (at 120Hz, 20°C)	WV	6.3	10	16	25	35 ~ 50	63 ~ 80
	tan $\delta$	0.24	0.19	0.16	0.14	0.12	0.08
Low temperature characteristics (Impedance ratio at 120Hz)	WV	6.3	10	16	25	35 ~ 50	63 ~ 80
	Z-25°C/Z+20°C	2	2	2	2	2	2
	Z-55°C/Z+20°C	3	3	3	3	3	3
Load life (after application of the rated voltage for 2000 hours at 105°C)	Leakage current	Less than specified value					
	Capacitance change	Within $\pm 25\%$ of initial value					
	tan $\delta$	Less than 200% of specified value (63~80V : 300%)					
Shelf life (at 105°C)	After 1000 hours no load test, leakage current, capacitance and tan $\delta$ are same as load life value. The measurement shall be performed at 20°C by the KS C IEC 60384 - 4						
Resistance to soldering heat	The following specifications shall be satisfied when the capacitors are restored to 20°C after exposing them at 250°C for 10 seconds.						
	Leakage current	Less than specified value					
	Capacitance change	Within $\pm 10\%$ of initial value					
	tan $\delta$	Less than specified value					

### DRAWING

Unit : mm

-Series code of CG is "CG"

( $\varnothing 6.3, \varnothing 6 \times 6.2$ )

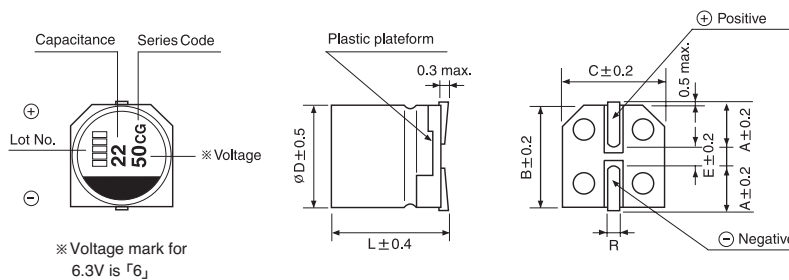

$\varnothing D$	A	B	C	E	R
6.3 × 7.7	2.4	6.6	6.6	2.2	0.5~0.8
8 × 10	2.9	8.3	8.3	3.1	0.8~1.1
10 × 10	3.2	10.3	10.3	4.5	0.8~1.1

( $\varnothing 8 \times 10, \varnothing 10 \times 10$ )

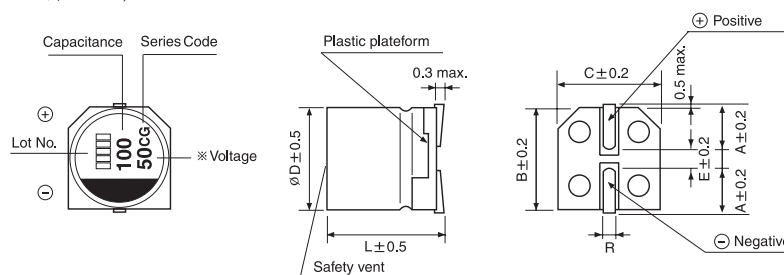

# SURFACE MOUNT ALUMINUM ELECTROLYTIC CAPACITORS

**CG** series

## ● DIMENSIONS & MAXIMUM PERMISSIBLE RIPPLE CURRENT

$\mu\text{F}$ \diagdown WV	6.3			10			16			25			35			50		
100																6.3×7.7	0.34	350
150										6.3×7.7	0.16	600	6.3×7.7	0.16	600			
220										6.3×7.7	0.16	600				8×10	0.18	670
330				6.3×7.7	0.16	600	6.3×7.7	0.16	600				8×10	0.08	850	10×10	0.12	900
470	6.3×7.7	0.16	600	6.3×7.7	0.16	600				8×10	0.08	850						
560													10×10	0.06	1190			
680	6.3×7.7	0.16	600				8×10	0.08	850				10×10	0.06	1190			
820										10×10	0.06	1190						
1000				8×10	0.08	850	10×10	0.06	1190									
1500	8×10	0.08	850	10×10	0.06	1190												
2200	10×10	0.06	1190															

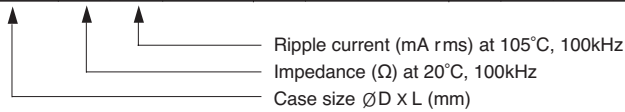

$\mu\text{F}$ \diagdown WV	63			80		
33				6.3×7.7	0.80	190
47	6.3×7.7	0.80	190			
68				8×10	0.40	300
100	8×10	0.40	300	10×10	0.25	500
220	10×10	0.25	500			

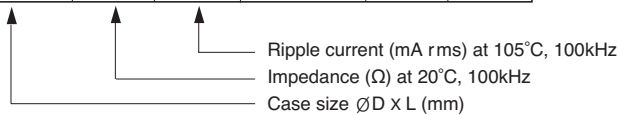

## ● FREQUENCY COEFFICIENT OF PERMISSIBLE RIPPLE CURRENT

Frequency	50Hz	120Hz	300Hz	1kHz	10kHz $\leq$
Coefficient	0.35	0.5	0.64	0.83	1.00

# SURFACE MOUNT ALUMINUM ELECTROLYTIC CAPACITORS



Upgrade

# CM

Chip type, Low Impedance  
Long Life Series



- Chip type, low impedance temperature range up to 105°C
- Designed for surface mounting on high density PC board
- Applicable to automatic insertion machine using carrier tape
- Complied to the RoHS directive
- AEC-Q200 compliant : Please contact us for more details.

Item	Characteristics							
<b>Operating temperature range</b>	-55 ~ +105°C							
<b>Leakage current max.</b>	I = 0.01CV or 3μA whichever is greater (after 2 minutes)							
<b>Capacitance tolerance</b>	±20% at 120Hz, 20°C							
<b>Dissipation factor max.</b> (at 120Hz, 20°C)	WV	6.3	10	16	25	35	50	63 ~ 100
	tanδ	0.26	0.19	0.16	0.14	0.13	0.12	0.10
<b>Low temperature characteristics</b> (Impedance ratio at 120Hz)	WV	6.3	10	16	25	35	50	63 ~ 100
	Z-25°C/Z+20°C	2	2	2	2	2	2	2
	Z-55°C/Z+20°C	4	4	4	3	3	3	3
<b>Load life</b> (after application of the rated voltage for 5000 hours at 105°C)	Leakage current	Less than specified value						
	Capacitance change	Within ±30% of the initial value						
	tanδ	Less than 250% of the specified value						
	Ø6.3 and 8×6.2 products are for 3000 hours							
<b>Shelf life (at 105°C)</b>	After 1000 hours no load test, leakage current, capacitance and tanδ are same as load life value.							
<b>Resistance to soldering heat</b>	The following specifications shall be satisfied when the capacitors are restored to 20°C after exposing them at 250°C for 10 seconds.							
	Leakage current	Less than specified value						
	Capacitance change	Within ±10% of initial value						
	tanδ	Less than specified value						

## DRAWING

Unit : mm

-Series code of CM is "M"

(Ø6.3, Ø8×6.2)

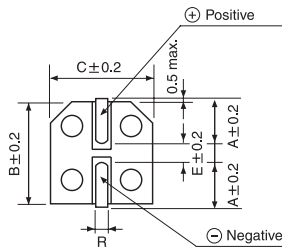
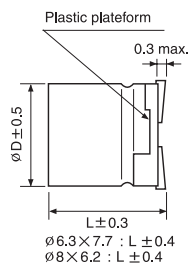
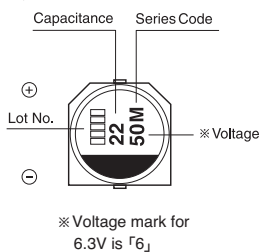

ØD×L	A	B	C	E	R
6.3×5.8	2.4	6.6	6.6	2.2	0.5~0.8
6.3×7.7	2.4	6.6	6.6	2.2	0.5~0.8
8×6.2	3.4	8.3	8.3	2.3	0.5~0.8
8×10	2.9	8.3	8.3	3.1	0.8~1.1
10×10	3.2	10.3	10.3	4.5	0.8~1.1
12.5×13.5	4.6	12.8	12.8	4.5	1.3~1.6

(Ø8×10, Ø10×10)

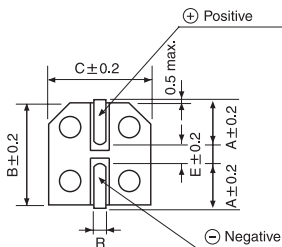
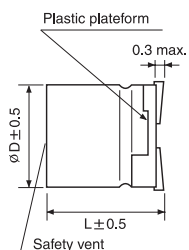
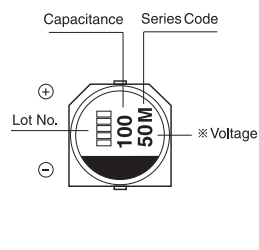

(Ø12.5)

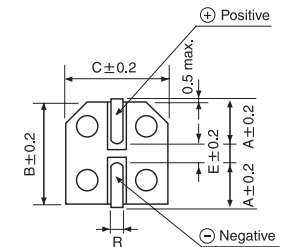
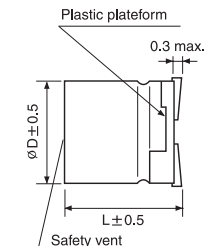
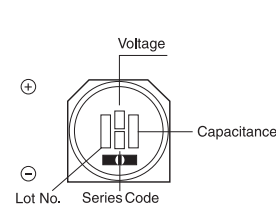

CHIP TYPES



# SURFACE MOUNT ALUMINUM ELECTROLYTIC CAPACITORS

**CM** series

## ● DIMENSIONS & MAXIMUM PERMISSIBLE RIPPLE CURRENT

$\mu\text{F}$ \diagdown WV	6.3			10			16			25			35			50		
2.2																4×5.3	6.00	30
10													5×5.3	2.00	160	6.3×5.8	1.00	170
15																6.3×5.8	0.86	170
22													6.3×5.3	1.00	160	6.3×5.8	0.86	170
33							5×5.3	1.50	150	5×5.3	1.05	160	6.3×5.3	0.85	220	6.3×7.7	0.66	280
							6.3×5.8	0.43	240				6.3×5.8	0.44	240	8×6.2	0.63	300
47				6.3×5.8	0.43	240	6.3×5.8	0.43	240	6.3×5.3	0.60	220	6.3×5.8	0.44	240	6.3×7.7	0.66	280
										6.3×5.8	0.43	240				8×6.2	0.63	300
68	6.3×5.8	0.43	240	6.3×5.8	0.39	240	6.3×5.8	0.39	240	6.3×5.8	0.39	240	6.3×7.7	0.32	290	6.3×7.7	0.30	420
													8×6.2	0.38	300			
100	6.3×5.8	0.43	240	6.3×5.8	0.39	240	6.3×5.8	0.39	240	6.3×7.7	0.32	290	6.3×7.7	0.32	290	8×10	0.32	350
										8×6.2	0.26	300	8×10	0.16	600	10×10	0.20	700
120													6.3×7.7	0.30	420			
150	6.3×5.8	0.43	240	6.3×5.8	0.39	240	6.3×7.7	0.32	290	8×10	0.16	600	8×10	0.16	600	10×10	0.20	700
180										6.3×7.7	0.30	420				8×10	0.18	670
220	6.3×5.8	0.43	240	6.3×7.7	0.36	290	6.3×7.7	0.32	290	8×10	0.16	600	8×10	0.16	600	10×10	0.20	700
				8×6.2	0.26	300	8×6.2	0.26	300	10×10	0.15	700	10×10	0.08	850			
270							6.3×7.7	0.30	420							10×10	0.14	750
330	6.3×7.7	0.32	290	6.3×7.7	0.30	420	8×10	0.16	600	8×10	0.16	600	8×10	0.08	850	8×10	0.08	850
	8×6.2	0.26	300	8×10	0.16	600				10×10	0.08	850						
470	8×10	0.16	600	8×10	0.16	600	8×10	0.16	600	8×10	0.08	850	10×10	0.10	850			
							10×10	0.08	850				12.5×13.5	0.08	900			
560													10×10	0.06	850			
680	8×10	0.16	600	8×10	0.16	600	8×10	0.08	850	10×10	0.10	850	12.5×13.5	0.08	900			
				10×10	0.08	850												
820				8×10	0.16	600				10×10	0.06	850						
1000	8×10	0.17	450	10×10	0.08	850	10×10	0.08	850	12.5×13.5	0.10	900	12.5×13.5	0.08	900			
	10×10	0.08	850				12.5×13.5	0.08	900									
1200				10×10	0.08	850												
1500							12.5×13.5	0.08	900									
2200				12.5×13.5	0.08	1000												
3300	12.5×13.5	0.06	1100															

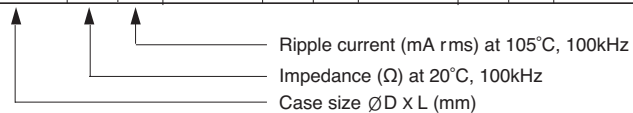

$\mu\text{F}$ \diagdown WV	63			80			100		
10	6.3×7.7	2.1	80	8×10	1.3	130	8×10	2.0	140
22	6.3×7.7	2.1	120	8×10	1.3	130	10×10	1.5	330
33	8×10	1.0	250	10×10	1.0	200	12.5×13.5	1.0	500
47	8×10	1.0	250	12.5×13.5	0.8	500	12.5×13.5	1.0	500
68	10×10	0.8	400	12.5×13.5	0.8	500	12.5×13.5	1.0	500
100	10×10	0.8	400	12.5×13.5	0.8	500	12.5×13.5	1.0	500
150	12.5×13.5	0.6	800	12.5×13.5	0.8	500			
220	12.5×13.5	0.6	800						

## ● FREQUENCY COEFFICIENT OF PERMISSIBLE RIPPLE CURRENT

Frequency	50Hz	120Hz	300Hz	1kHz	10kHz $\leq$
Coefficient	0.35	0.50	0.64	0.83	1.00

## UC Chip type, High Reliability Series

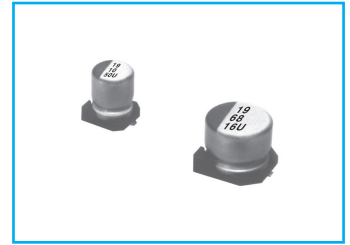

- Chip type, high temperature range, for 125°C use
- Designed for surface mounting on high density PC board
- Applicable to automatic insertion machine using carrier tape
- Complied to the RoHS directive
- AEC-Q200 compliant : Please contact us for more details.



Item	Characteristics																								
Operating temperature range	-40 ~ +125°C																								
Leakage current max.	WV ≤ 100 I = 0.03CV or 4μA whichever is greater (after 2 minutes) WV ≥ 160 I = 0.04CV + 100μA(after 1 minutes)																								
Capacitance tolerance	±20% at 120Hz, 20°C																								
Dissipation factor max. (at 120Hz, 20°C)	<table border="1"> <tr> <td>WV</td> <td>10</td> <td>16</td> <td>25</td> <td>35~63</td> <td>80~100</td> <td>160~200</td> <td>250~400</td> </tr> <tr> <td>tanδ</td> <td>0.32</td> <td>0.24</td> <td>0.21</td> <td>0.18</td> <td>0.12</td> <td>0.2</td> <td>0.24</td> </tr> </table>	WV	10	16	25	35~63	80~100	160~200	250~400	tanδ	0.32	0.24	0.21	0.18	0.12	0.2	0.24								
	WV	10	16	25	35~63	80~100	160~200	250~400																	
tanδ	0.32	0.24	0.21	0.18	0.12	0.2	0.24																		
Low temperature characteristics (Impedance ratio at 120Hz)	<table border="1"> <tr> <td>WV</td> <td>10</td> <td>16</td> <td>25</td> <td>35~50</td> <td>63~100</td> <td>160~200</td> <td>250~400</td> </tr> <tr> <td>Z-25°C/Z+20°C</td> <td>8</td> <td>6</td> <td>4</td> <td>4</td> <td>3</td> <td>3</td> <td>6</td> </tr> <tr> <td>Z-40°C/Z+20°C</td> <td>12</td> <td>8</td> <td>6</td> <td>4</td> <td>4</td> <td>6</td> <td>10</td> </tr> </table>	WV	10	16	25	35~50	63~100	160~200	250~400	Z-25°C/Z+20°C	8	6	4	4	3	3	6	Z-40°C/Z+20°C	12	8	6	4	4	6	10
	WV	10	16	25	35~50	63~100	160~200	250~400																	
	Z-25°C/Z+20°C	8	6	4	4	3	3	6																	
Z-40°C/Z+20°C	12	8	6	4	4	6	10																		
Load life (after application of the rated voltage for 2000 hours at 125°C)	Leakage current	Less than specified value																							
	Capacitance change	Within ±30% of initial value																							
	tanδ	Less than 300% of specified value																							
Shelf life (at 125°C)	After 1000 hours no load test, leakage current, capacitance and tanδ are same as load life value. The measurement shall be performed at 20°C by the KS C IEC 60384 - 4																								
Resistance to soldering heat	The following specifications shall be satisfied when the capacitors are restored to 20°C after exposing them at 250°C for 30 seconds.																								
	Leakage current	Less than specified value																							
	Capacitance change	Within ±10% of initial value																							
	tanδ	Less than specified value																							

● DRAWING (See page 58) -Series code of UC is “U”

● DIMENSIONS & MAXIMUM PERMISSIBLE RIPPLE CURRENT

μF \ WV	10	16	25	35	50	63
4.7				4×5.3 18		
10			4×5.3 25	4×5.3 23	8×6.2 65	8×6.2 40
15				5×5.3 23		
22					8×6.2 65	8×10 67
33				8×6.2 65	8×6.2 65 8×10 125	8×10 67
47			8×6.2 65	8×6.2 100 8×10 125	10×10 200	10×10 115
68		8×6.2 65	8×6.2 65	8×10 170 10×10 200	12.5×13.5 525	12.5×13.5 335
100	8×6.2 65	8×10 125	8×10 125	8×10 170 10×10 200	12.5×13.5 525	12.5×13.5 335
220	8×10 125	10×10 200	8×10 150 10×10 200	12.5×13.5 525		
330	10×10 200	10×10 200	12.5×13.5 525			
470	10×10 200	12.5×13.5 525				
1000	12.5×13.5 525					

↑ ↑  
Ripple current (mA rms) at 125°C, 120Hz  
Case size ØD×L(mm)

μF \ WV	80	100	160	200	250	400
3.3						12.5×13.5 70
4.7					12.5×13.5 85	12.5×13.5 70
10	8×10 45	8×10 45	10×10 65	10×10 65	12.5×13.5 85	
22	8×10 45	8×10 45 10×10 80	12.5×13.5 85	12.5×13.5 85		
33	10×10 80	10×10 80				
47	10×10 80	12.5×13.5 300				
68	12.5×13.5 300	12.5×13.5 300				

↑ ↑  
Ripple current (mA rms) at 125°C, 120Hz  
Case size ØD×L(mm)

● FREQUENCY COEFFICIENT OF PERMISSIBLE RIPPLE CURRENT

Frequency	50Hz	120Hz	300Hz	1kHz	10kHz ≤
Coefficient	0.70	1.00	1.17	1.36	1.50

# SURFACE MOUNT ALUMINUM ELECTROLYTIC CAPACITORS

**UR** Chip type, High Reliability Series

 **Low ESR**   
  **Long Life**   
  **Solvent Proof**  
 WV ≤ 100V



UC → **UR**  
 Low ESR.

- Chip type, high temperature range, for 125°C use
- Lower ESR than UC series
- Designed for surface mounting on high density PC board
- Applicable to automatic insertion machine using carrier tape
- AEC-Q200 compliant : Please contact us for more details.
- Complied to the RoHS directive

Item	Characteristics	
<b>Operating temperature range</b>	-40 ~ +125°C	
<b>Leakage current max.</b>	WV ≤ 100	WV ≥ 160
	I = 0.01CV or 3μA whichever is greater (after 2 minutes)	I = 0.04CV + 100μA (after 2 minutes)
<b>Capacitance tolerance</b>	±20% at 120Hz, 20°C	
<b>Dissipation factor max. (at 120Hz, 20°C)</b>	WV	10    16    25    35    50~80    100    160~250    400
	tanδ	0.22    0.19    0.16    0.14    0.12    0.10    0.20    0.24
<b>Temperature characteristics (Impedance ratio at 120Hz)</b>	WV	10    16    25    35~100    160~250    400
	Z-25°C/Z+20°C	3    2    2    2    3    6
	Z-40°C/Z+20°C	4    3    3    3    6    10
<b>Load life (after application of the rated voltage for 5000 hours at 125°C)</b>	Leakage current	Less than specified value
	Capacitance change	Within ±30% of initial value
	tanδ	Less than 300% of specified value
	ØD	~ 80V    100V    160V ~
	ØD = 4, 5, 6.3 (L ≤ 5.8)	1000 hours    -    -
	6.3 × 7.7	2000 hours    -    -
8 × 6.2	3000 hours    -    -	
ØD = 8, 10	5000 hours    2000 hours    2000 hours	
ØD = 12.5	5000 hours    5000 hours    2000 hours	
<b>Shelf life (at 125°C)</b>	After 1000 hours no load test, leakage current, capacitance and tanδ are same as load life value. The measurement shall be performed at 20°C by the KS C IEC 60384-4	
<b>Resistance to soldering heat</b>	The following specifications shall be satisfied when the capacitors are restored to 20°C after exposing them at 250°C for 10 seconds.	
	Leakage current	Less than specified value
	Capacitance change	Within ±10% of initial value
	tanδ	Less than specified value

## ● DRAWING - Series code of UR is "R"

Unit : mm

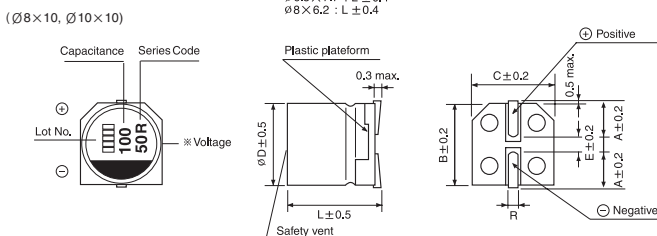
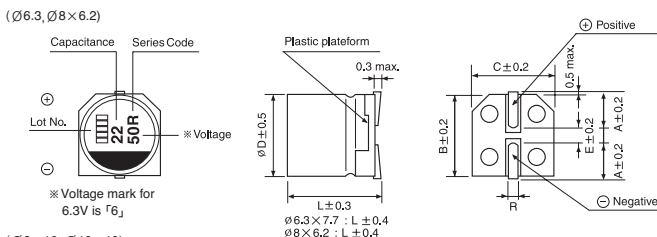
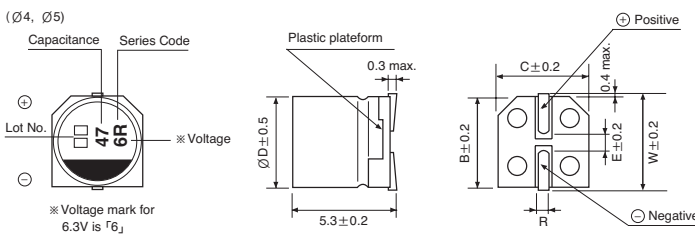

ØD × L	W	A	B	C	E	R
4 × 5.3	4.8		4.3	4.3	1.0	0.5~0.8
5 × 5.3	5.8		5.3	5.3	1.4	0.5~0.8
6.3 × 5.3		2.4	6.6	6.6	2.2	0.5~0.8
6.3 × 5.8		2.4	6.6	6.6	2.2	0.5~0.8
6.3 × 7.7		2.4	6.6	6.6	2.2	0.5~0.8
8 × 6.2		3.3	8.3	8.3	2.3	0.5~0.8
8 × 10		2.9	8.3	8.3	3.1	0.8~1.1
10 × 10		3.2	10.3	10.3	4.5	0.8~1.1
12.5 × 13.5		4.6	12.8	12.8	4.5	1.3~1.6

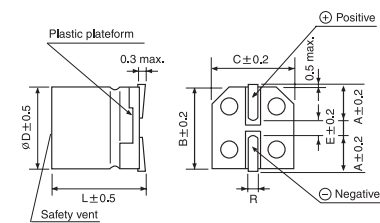
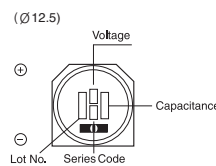

## UR series

### ● DIMENSIONS & MAXIMUM PERMISSIBLE RIPPLE CURRENT

$\mu\text{F}$ \diagdown WV	10			16			25			35																																																																																																																																																																																								
4.7										4×5.3	7.00	12																																																																																																																																																																																						
10				4×5.3	7.00	12	5×5.3	3.30	23	6.3×5.8	1.60	69																																																																																																																																																																																						
22	5×5.3	3.30	23	5×5.3	3.30	23	6.3×5.3	2.00	40	6.3×5.8	1.60	69											6.3×7.7	1.60	75	33	5×5.3	3.30	23	6.3×5.3	2.00	40	6.3×5.8	1.60	69	6.3×7.7	0.90	110	47	6.3×5.3	2.00	40	6.3×5.8	1.60	69	6.3×7.7	0.90	110	6.3×7.7	0.90	190								8×6.2	0.90	110	8×10	0.30	264	100	8×6.2	0.90	110	8×6.2	0.90	110	6.3×7.7	0.90	150	8×10	0.30	264								8×10	0.30	264				220	8×10	0.30	264	8×10	0.30	355	8×10	0.30	355	8×10	0.30	350											10×10	0.20	400	330	8×10	0.30	355	10×10	0.20	400	10×10	0.20	400	12.5×13.5	0.14	750								12.5×13.5	0.14	750				470	10×10	0.20	400	12.5×13.5	0.14	750	12.5×13.5	0.14	750				680										12.5×13.5	0.10	1000	820							12.5×13.5	0.10	800				1000							12.5×13.5	0.06	1700			
										6.3×7.7	1.60	75																																																																																																																																																																																						
33	5×5.3	3.30	23	6.3×5.3	2.00	40	6.3×5.8	1.60	69	6.3×7.7	0.90	110																																																																																																																																																																																						
47	6.3×5.3	2.00	40	6.3×5.8	1.60	69	6.3×7.7	0.90	110	6.3×7.7	0.90	190								8×6.2	0.90	110	8×10	0.30	264	100	8×6.2	0.90	110	8×6.2	0.90	110	6.3×7.7	0.90	150	8×10	0.30	264								8×10	0.30	264				220	8×10	0.30	264	8×10	0.30	355	8×10	0.30	355	8×10	0.30	350											10×10	0.20	400	330	8×10	0.30	355	10×10	0.20	400	10×10	0.20	400	12.5×13.5	0.14	750								12.5×13.5	0.14	750				470	10×10	0.20	400	12.5×13.5	0.14	750	12.5×13.5	0.14	750				680										12.5×13.5	0.10	1000	820							12.5×13.5	0.10	800				1000							12.5×13.5	0.06	1700																																										
							8×6.2	0.90	110	8×10	0.30	264																																																																																																																																																																																						
100	8×6.2	0.90	110	8×6.2	0.90	110	6.3×7.7	0.90	150	8×10	0.30	264								8×10	0.30	264				220	8×10	0.30	264	8×10	0.30	355	8×10	0.30	355	8×10	0.30	350											10×10	0.20	400	330	8×10	0.30	355	10×10	0.20	400	10×10	0.20	400	12.5×13.5	0.14	750								12.5×13.5	0.14	750				470	10×10	0.20	400	12.5×13.5	0.14	750	12.5×13.5	0.14	750				680										12.5×13.5	0.10	1000	820							12.5×13.5	0.10	800				1000							12.5×13.5	0.06	1700																																																																				
							8×10	0.30	264																																																																																																																																																																																									
220	8×10	0.30	264	8×10	0.30	355	8×10	0.30	355	8×10	0.30	350											10×10	0.20	400	330	8×10	0.30	355	10×10	0.20	400	10×10	0.20	400	12.5×13.5	0.14	750								12.5×13.5	0.14	750				470	10×10	0.20	400	12.5×13.5	0.14	750	12.5×13.5	0.14	750				680										12.5×13.5	0.10	1000	820							12.5×13.5	0.10	800				1000							12.5×13.5	0.06	1700																																																																																														
										10×10	0.20	400																																																																																																																																																																																						
330	8×10	0.30	355	10×10	0.20	400	10×10	0.20	400	12.5×13.5	0.14	750								12.5×13.5	0.14	750				470	10×10	0.20	400	12.5×13.5	0.14	750	12.5×13.5	0.14	750				680										12.5×13.5	0.10	1000	820							12.5×13.5	0.10	800				1000							12.5×13.5	0.06	1700																																																																																																																								
							12.5×13.5	0.14	750																																																																																																																																																																																									
470	10×10	0.20	400	12.5×13.5	0.14	750	12.5×13.5	0.14	750																																																																																																																																																																																									
680										12.5×13.5	0.10	1000																																																																																																																																																																																						
820							12.5×13.5	0.10	800																																																																																																																																																																																									
1000							12.5×13.5	0.06	1700																																																																																																																																																																																									

$\mu\text{F}$ \diagdown WV	50			63			80			100		
10	6.3×5.8	2.80	51	6.3×5.8	2.50	55	8×10	1.20	70	8×10	1.60	70
				8×6.2	2.00	60						
22	6.3×7.7	2.20	70	8×10	1.00	70	10×10	0.55	115	10×10	1.60	95
	8×6.2	1.60	83									
33	8×10	0.70	192	10×10	0.55	115	10×10	0.55	115	10×10	0.80	115
47	10×10	0.50	330	10×10	0.55	115	10×10	0.55	115	12.5×13.5	0.33	450
							12.5×13.5	0.33	450			
100	10×10	0.50	330	10×10	0.55	115	12.5×13.5	0.33	450	12.5×13.5	0.33	450
				12.5×13.5	0.33	450						
220	12.5×13.5	0.23	550	12.5×13.5	0.33	450						
330	12.5×13.5	0.23	550									
470	12.5×13.5	0.23	550									

Ripple current (mA rms) at 125°C, 100kHz  
 ESR ( $\Omega$ ) at 20°C, 100kHz  
 Case size  $\varnothing D \times L$  (mm)

$\mu\text{F}$ \diagdown WV	160		200		250		400	
1							10×10	18
2.2							10×10	26
3.3							10×10	37
4.7					12.5×13.5	70	12.5×13.5	70
10	12.5×13.5	100	12.5×13.5	100	12.5×13.5	100		
22	12.5×13.5	120	12.5×13.5	120				

Ripple current (mA rms) at 125°C, 120Hz  
 Case size  $\varnothing D \times L$  (mm)

### ● FREQUENCY COEFFICIENT OF PERMISSIBLE RIPPLE CURRENT

Frequency		120Hz	1kHz	10kHz	100kHz
wv	cap.				
≤ 100	~ 10	0.66	0.86	0.93	1.00
	22 ~	0.93	0.97	1.00	1.00
160 ≤	-	1.00	1.50	1.75	1.80

# SURFACE MOUNT ALUMINUM ELECTROLYTIC CAPACITORS

Upgrade

**UN** Chip type, High Reliability Series

**IEI** Low ESR **S** Solvent Proof

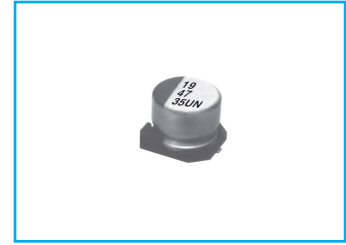

- Chip type, high temperature range, for +125°C use
- Lower ESR than UR series
- Application to automotive system
- Complied to the RoHS directive

UR → **UN**  
Low ESR.

Item	Characteristics						
Operating temperature range	-40 ~ +125°C						
Leakage current max.	I = 0.01CV or 3μA whichever is greater (after 2 minutes)						
Capacitance tolerance	±20% at 120Hz, 20°C						
Dissipation factor max. (at 120Hz, 20°C)	WV	10	16	25	35	50	63
	tanδ	0.30	0.23	0.18	0.16	0.16	0.14
Low temperature characteristics (Impedance ratio at 120Hz)	WV	10	16	25	35	50	63
	Z-40°C/Z+20°C	4	3	3	3	3	3
Load life (after application of the rated voltage for 3000 hours at 125°C)	Leakage current	Less than specified value					
	Capacitance change	Within ±30% of initial value					
	tanδ	Less than 300% of specified value					
Shelf life (at 125°C)	After 1000 hours no load test, leakage current, capacitance and tanδ are same as load life value. The measurement shall be performed at 20°C by the KS C IEC 60384 - 4						
Resistance to soldering heat	The following specifications shall be satisfied when the capacitors are restored to 20°C after exposing them at 250°C for 10 seconds.						
	Leakage current	Less than specified value					
	Capacitance change	Within ±10% of initial value					
	tanδ	Less than specified value					

● DRAWING (See page 58)

Unit : mm

-Series code of UN is "UN"

∅D×L	A	B	C	E	R
6.3×7.7	2.4	6.6	6.6	2.2	0.5~0.8
8×10	2.9	8.3	8.3	3.1	0.8~1.1
10×10	3.2	10.3	10.3	4.5	0.8~1.1

● DIMENSIONS & MAXIMUM PERMISSIBLE RIPPLE CURRENT

WV	μF	∅D×L(mm)	ESR (Ω)max.		Ripple current (mA rms)
			20°C 100kHz	-40°C 100kHz	
10	220	6.3 × 7.7	0.30	3.0	240
	470	8 × 10	0.20	2.0	350
	680	10 × 10	0.15	1.5	550
16	220	6.3 × 7.7	0.30	3.0	240
	330	8 × 10	0.20	2.0	350
	680	10 × 10	0.15	1.5	550
25	100	6.3 × 7.7	0.30	3.0	240
	220	8 × 10	0.20	2.0	350
	330	10 × 10	0.15	1.5	550
35	47	6.3 × 7.7	0.30	3.0	240
	100	6.3 × 7.7	0.30	3.0	240
	220	8 × 10	0.20	2.0	350
	330	10 × 10	0.15	1.5	550
50	47	6.3 × 7.7	0.50	5.0	190
	150	8 × 10	0.30	4.0	320
	220	10 × 10	0.20	3.0	500
63	33	6.3 × 7.7	0.80	8.0	150
	68	8 × 10	0.40	6.0	250
	100	10 × 10	0.25	3.0	400

● FREQUENCY COEFFICIENT OF PERMISSIBLE RIPPLE CURRENT

Frequency	50Hz	120Hz	300Hz	1kHz	10kHz ≤
Coefficient	0.35	0.50	0.64	0.83	1.00

## KC Chip type, High Reliability Series



- Chip type, high temperature range, for 135°C use
- Designed for surface mounting on high density PC board
- Applicable to automatic insertion machine using carrier tape
- Complied to the RoHS directive
- AEC-Q200 compliant : Please contact us for more details.

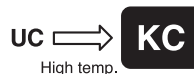

Item	Characteristics				
Operating temperature range	-40 ~ +135°C				
Leakage current max.	I = 0.01CV or 3μA whichever is greater (after 2 minutes)				
Capacitance tolerance	±20% at 120Hz, 20°C				
Dissipation factor max. (at 120Hz, 20°C)	WV	10	16	25	35
	tanδ	0.30	0.23	0.18	0.16
Low temperature characteristics (Impedance ratio at 120Hz)	WV	10	16	25	35
	Z-25°C/Z+20°C	8	6	4	4
	Z-40°C/Z+20°C	12	8	6	4
Load life (after application of the rated voltage for 2000 hours at 135°C)	Capacitance change	Within ±30% of initial value			
	tanδ	Less than 300% of the specified value			
	Leakage current	Less than specified value			
Shelf life(at 135°C)	After 1000 hours no load test, leakage current, capacitance and tanδ are same as load life value. The measurement shall be performed at 20°C by the KS C IEC 60384 - 4				
Resistance to soldering heat	The following specifications shall be satisfied when the capacitors are restored to 20°C after exposing them at 250°C for 10 seconds.				
	Leakage current	Less than specified value			
	Capacitance change	Within ±10% of initial value			
	tanδ	Less than specified value			

### ● DRAWING (See page 58)

-Series code of KC is "C"

### ● DIMENSIONS & MAXIMUM PERMISSIBLE RIPPLE CURRENT

μF \ WV	10			16			25			35		
47										8×10	0.20	270
68										8×10	0.20	270
100				8×10	0.20	270	8×10	0.20	270	8×10	0.20	270
220	8×10	0.20	270	8×10	0.20	270	10×10	0.15	500	10×10	0.15	500
330	10×10	0.20	270	10×10	0.15	500	10×10	0.15	500			
470	10×10	0.15	500	10×10	0.15	500						

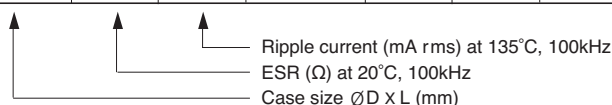

### ● FREQUENCY COEFFICIENT OF PERMISSIBLE RIPPLE CURRENT

Frequency	50Hz	120Hz	300Hz	1kHz	10kHz ≤
Coefficient	0.35	0.50	0.64	0.83	1.00

# SURFACE MOUNT ALUMINUM ELECTROLYTIC CAPACITORS

**CW** Chip type, High Reliability Series

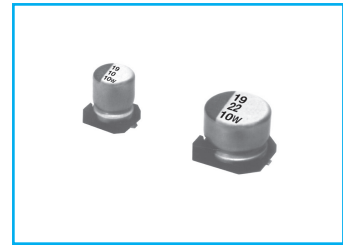

- Chip type, high temperature range, for 150°C use
- Applicable to automatic insertion machine using carrier tape
- Complied to the RoHS directive
- AEC-Q200 compliant : Please contact us for more details.

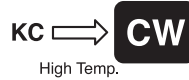

Item	Characteristics					
Operating temperature range	-40 ~ +150°C					
Leakage current	I = 0.03CV or 4μA whichever is greater (after 2 minutes)					
Capacitance tolerance	±20% at 120Hz, 20°C					
Dissipation factor max. (at 120Hz, 20°C)	WV	10	16	25	35	50
	tanδ	0.30	0.20	0.16	0.14	0.14
Low temperature characteristics (Impedance ratio at 120Hz)	WV	10	16	25	35	50
	Z-25°C/Z+20°C	8	6	4	4	4
	Z-40°C/Z+20°C	12	10	8	6	6
Load life (after application of the rated voltage for 2000 hours at 150°C)	Leakage current	Less than specified value				
	Capacitance change	Within ±30% of initial value				
	tanδ	Less than 300% of the specified value				
Shelf life (at 150°C)	After 1000 hours no load test, leakage current, capacitance and tanδ are same as load life value. The measurement shall be performed at 20°C by the KS C IEC 60384 - 4					
Resistance to soldering heat	The following specifications shall be satisfied when the capacitors are restored to 20°C after exposing them at 250°C for 10 seconds.					
	Leakage current	Less than specified value				
	Capacitance change	Within ±10% of initial value				
	tanδ	Less than specified value				

● DRAWING (See page 58)

-Series code of CW is "W"

● DIMENSIONS & MAXIMUM PERMISSIBLE RIPPLE CURRENT

μF \ WV	10		16		25		35		50	
33									10×10	75
47							10×10	90	10×10	90
68							10×10	105	12.5×13.5	132
100					10×10	160	10×10	132	12.5×13.5	167
220			10×10	163	10×10	200	12.5×13.5	249		
330	10×10	183	10×10	200	12.5×13.5	304				
470	10×10	218	12.5×13.5	304						
1000	12.5×13.5	405								

↑ Ripple current (mA rms) at 150°C, 120Hz  
Case size ØD×L(mm)

● FREQUENCY COEFFICIENT OF PERMISSIBLE RIPPLE CURRENT

Frequency	50Hz	120Hz	300Hz	1kHz	10kHz≤
Coefficient	0.70	1.00	1.17	1.36	1.50

# SURFACE MOUNT ALUMINUM ELECTROLYTIC CAPACITORS



New



Chip type, High Temperature  
Low ESR Series

- Chip type, high temperature range, for +150°C use
- Lower ESR
- Application to automotive system
- Complied to the RoHS directive



Item	Characteristics		
Operating temperature range	-40 ~ +150°C		
Leakage current max.	I = 0.01CV or 3μA whichever is greater (after 2 minutes)		
Capacitance tolerance	±20% at 120Hz, 20°C		
Dissipation factor max. (at 120Hz, 20°C)	WV	25	35
	tanδ	0.16	0.14
Low temperature characteristics (Impedance ratio at 120Hz)	WV	25	35
	Z-40°C/Z+20°C	6	4
Load life (after application of the rated voltage for 2000 hours at 150°C)	Leakage current	Less than specified value	
	Capacitance change	Within ±40% of initial value	
	tanδ	Less than 400% of specified value	
	∅8 products are for 1500 hours		
Shelf life (at 125°C)	After 1000 hours no load test, leakage current, capacitance and tanδ are same as load life value. The measurement shall be performed at 20°C by the KS C IEC 60384 - 4		
Resistance to soldering heat	The following specifications shall be satisfied when the capacitors are restored to 20°C after exposing them at 250°C for 10 seconds.		
	Leakage current	Less than specified value	
	Capacitance change	Within ±10% of initial value	
	tanδ	Less than specified value	

## ● DRAWING (See page 71)

Unit : mm

-Series code of CQ is "CQ"

∅D×L	A	B	C	E	R
8×10	2.9	8.3	8.3	3.1	0.8~1.1
10×10	3.2	10.3	10.3	4.5	0.8~1.1

CHIP TYPES

## ● DIMENSIONS & MAXIMUM PERMISSIBLE RIPPLE CURRENT

WV	μF	∅D×L(mm)	tan δ	ESR (Ω)max.	Ripple current (mA rms)
				20°C 100kHz	150°C 100kHz
25	150	8 × 10	0.16	0.26	80
	270	10 × 10	0.16	0.15	120
35	100	8 × 10	0.14	0.26	80
	180	10 × 10	0.14	0.15	120

## ● FREQUENCY COEFFICIENT OF PERMISSIBLE RIPPLE CURRENT

Frequency	120Hz	300Hz	1kHz	10kHz≤
Coefficient	0.67	0.79	0.91	1.00



# SURFACE MOUNT ALUMINUM ELECTROLYTIC CAPACITORS

**NC** Chip type, Non-polarized Series

**NP** Non-polarized **S** Solvent Proof

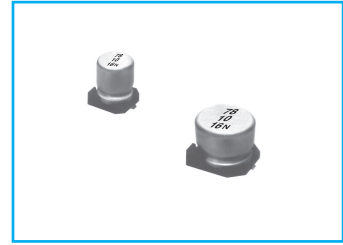

- Chip type with 5.5mmL height
- Designed for surface mounting on high density PC board
- Applicable to automatic insertion machine using carrier tape
- Complied to the RoHS directive
- AEC-Q200 compliant : Please contact us for more details.



Item	Characteristics						
Operating temperature range	-40 ~ +85°C						
Leakage current max.	I = 0.05CV or 10 $\mu$ A whichever is greater (after 2 minutes)						
Capacitance tolerance	$\pm 20\%$ at 120Hz, 20°C						
Dissipation factor max. (at 120Hz, 20°C)	WV	6.3	10	16	25	35	50
	tan $\delta$	0.24	0.20	0.17	0.17	0.15	0.15
Low temperature characteristics (Impedance ratio at 120Hz)	WV	6.3	10	16	25	35	50
	Z-25°C/Z+20°C	4	3	2	2	2	2
	Z-40°C/Z+20°C	8	6	4	4	3	3
Load life (after application of the rated voltage for 2000 hours at 85°C)	Leakage current	Less than specified value					
	Capacitance change	Within $\pm 20\%$ of initial value					
	tan $\delta$	Less than 200% of specified value					
	Test method	Polarity reverse each 250 hours					
Shelf life (at 85°C)	After 1000 hours no load test, leakage current, capacitance and tan $\delta$ are same as load life value. The measurement shall be performed at 20°C by the KS C IEC 60384 - 4						
Resistance to soldering heat	The following specifications shall be satisfied when the capacitors are restored to 20°C after exposing them at 250°C for 10 seconds.						
	Leakage current	Less than specified value					
	Capacitance change	Within $\pm 10\%$ of initial value					
	tan $\delta$	Less than specified value					

## ● DRAWING

Unit : mm

-Series code of NC is "N"

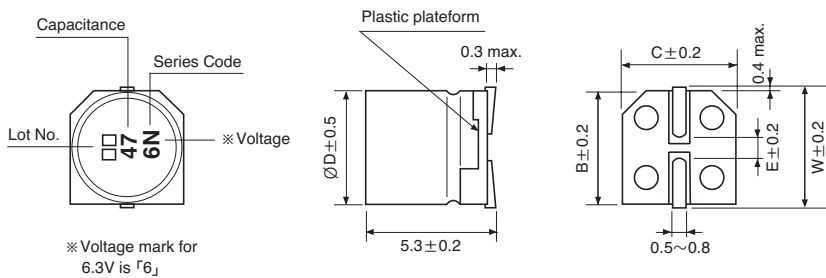

ØD	W	B	C	E
4	4.8	4.3	4.3	1.0
5	5.8	5.3	5.3	1.4
6.3	7.1	6.6	6.6	2.2

## ● DIMENSIONS & MAXIMUM PERMISSIBLE RIPPLE CURRENT

$\mu$ F	WV	6.3	10	16	25	35	50
1.0							4×5.3 8.4
2.2						4×5.3 8.4	5×5.3 13
3.3					5×5.3 12	5×5.3 16	5×5.3 17
4.7				4×5.3 12	5×5.3 16	5×5.3 18	6.3×5.3 20
10		4×5.3 17	5×5.3 23	6.3×5.3 27	6.3×5.3 29		
22	5×5.3 28	6.3×5.3 33	6.3×5.3 37				
33	6.3×5.3 37	6.3×5.3 41	6.3×5.3 49				
47	6.3×5.3 45						

Ripple current (mA rms) at 85°C, 120Hz  
Case size ØD x L (mm)

## CN 105°C Non-polarized Series

Non-polarized    
 Solvent Proof



- Chip type with 5.5mmL height
- Designed for surface mounting on high density PC board
- Applicable to automatic insertion machine using carrier tape
- Complied to the RoHS directive
- AEC-Q200 compliant : Please contact us for more details.

Wide temp.

Item	Characteristics							
<b>Operating temperature range</b>	WV ≤ 25 : -55 ~ +105°C    WV ≥ 35 : -40 ~ +105°C							
<b>Leakage current max.</b>	I = 0.05CV or 10μA whichever is greater (after 2 minutes)							
<b>Capacitance tolerance</b>	± 20% at 120Hz, 20°C							
<b>Dissipation factor max. (at 120Hz, 20°C)</b>	WV	6.3	10	16	25	35	50	
	tanδ	0.32	0.26	0.24	0.20	0.18	0.18	
<b>Low temperature characteristics (Impedance ratio at 120Hz)</b>	WV	6.3	10	16	25	35	50	
	Z-25°C/Z+20°C	4	3	2	2	2	2	
	Z-40°C/Z+20°C	-	-	-	-	4	4	
	Z-55°C/Z+20°C	8	5	4	3	-	-	
<b>Load life (after application of the rated voltage for 1000 hours at 105°C)</b>	Leakage current	Less than specified value						
	Capacitance change	Within ± 20% of initial value						
	tanδ	Less than 200% of specified value						
	Test method	Polarity reverse each 250 hours						
<b>Shelf life (at 105°C)</b>	After 1000 hours no load test, leakage current, capacitance and tanδ are same as load life value. The measurement shall be performed at 20°C by the KS C IEC 60384 - 4							
<b>Resistance to soldering heat</b>	The following specifications shall be satisfied when the capacitors are restored to 20°C after exposing them at 250°C for 10 seconds.							
	Leakage current	Less than specified value						
	Capacitance change	Within ± 10% of initial value						
	tanδ	Less than specified value						

● DRAWING (See page 82)

-Series code of CN is "C"

CHIP TYPES

● DIMENSIONS & MAXIMUM PERMISSIBLE RIPPLE CURRENT

μF \ WV	6.3	10	16	25	35	50
1.0						4×5.3    8.4
2.2					4×5.3    8.4	5×5.3    13
3.3				5×5.3    12	5×5.3    16	5×5.3    17
4.7			4×5.3    12	5×5.3    16	5×5.3    18	6.3×5.3    20
10		4×5.3    17	5×5.3    23	6.3×5.3    27	6.3×5.3    29	
22	5×5.3    28	6.3×5.3    33	6.3×5.3    37			
33	6.3×5.3    37	6.3×5.3    41	6.3×5.3    49			
47	6.3×5.3    45					

Ripple current (mA rms) at 105°C, 120Hz  
Case size ØD×L (mm)



# 4 MINIATURE ALUMINUM ELECTROLYTIC CAPACITORS

---



# PACKING

## ● BULK PACKING QUANTITY(pcs) / BOX

SIZE		BULK (QUANTITY)		
ØD	L(mm)	V-Bag	INNER BOX	MIDDLE BOX
4	5, 7	500	10000	40000
5	5, 7, 11	500	7000	28000
6.3	5, 7, 11	500	6000	24000
8	5, 7	500	5000	20000
	11.5	300	3600	14400
10	12.5	200	2400	9600
	16	200	2000	8000
	20, 25	200	1600	6400
	30	100	1200	4800
12.5	16	100	1200	4800
	20	100	1000	4000
	25	100	900	3600
	30	100	800	3200
16	16	-	800	3200
	20	-	600	2400
	25	-	500	2000
	31.5, 35.5, 40	-	400	1600
	45, 50	-	250	1000
18	16	-	600	2400
	20	-	500	2000
	25, 31.5	-	400	1600
	35.5, 40	-	300	1200
	45, 50	-	250	1000

## ● CUTTING PACKING QUANTITY(pcs) / BOX

SIZE		CUTTING (QUANTITY)		
ØD	L(mm)	V-Bag	INNER BOX	MIDDLE BOX
4	5, 7	500	9000	36000
5	5, 7, 11	500	7000	28000
6.3	5, 7, 11	500	6000	24000
8	5, 7	500	5000	20000
	11.5	300	3600	14400
10	12.5	-	800	12800
	16	-	600	9600
	20	-	500	8000
	25	-	400	6400
	30	-	350	5600
12.5	16	-	400	6400
	20	-	300	4800
	25	-	250	4000
16	16, 20, 25	-	400	1200
	31.5, 35.5	-	400	1200
	40 ↑	-	400	1200
18	16, 20, 25	-	300	900
	31.5, 35.5	-	300	900
	40 ↑	-	300	900
20	41	-	240	720
22	35.5 ↓	-	200	600
	40 ↑	-	200	600

# TAPING

● Ammo

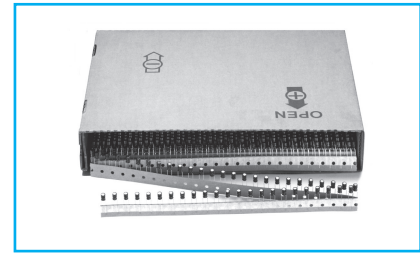

● Lead Taping Capacitors for Automatic Insertion

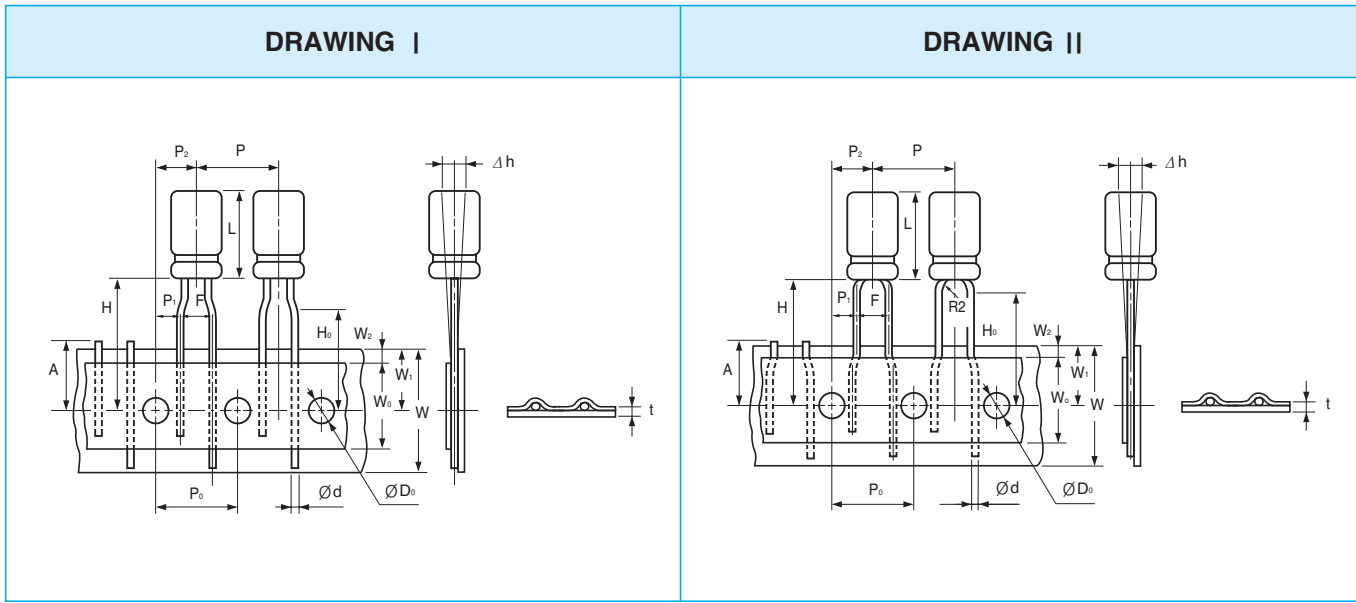

● DIMENSIONS

Unit : mm

Applicable Drawing No.			II				III		I						
Description	Symbol	Tolerance	Ø4	Ø5		Ø6.3	Ø8	Ø4	Ø5		Ø6.3		Ø8		
Case Height	L	*Note	5, 7	5	7~11	5	7~11	5	5, 7	5	7~11	5	7~11	5	9, 11.5
Lead Dia.	Ød	±0.05	0.45	0.45	0.5	0.45	0.5	0.45	0.45	0.5	0.5	0.45	0.5	0.45	0.6
Body Pitch	P	±1.0	12.7		12.7		12.7	12.7		12.7		12.7		12.7	12.7
Feeding Hole Pitch	P <sub>0</sub>	±0.2	12.7		12.7		12.7	12.7		12.7		12.7		12.7	12.7
Feeding Hole Alignment	P <sub>1</sub>	±0.7	5.1		5.1		5.1	3.85		3.85		3.85		3.85	3.85
Feeding Hole Alignment	P <sub>2</sub>	±1.0	6.35		6.35		6.35	6.35		6.35		6.35		6.35	6.35
Lead Center Spacing	F	+0.6 -0.2	2.5		2.5		2.5	5.0		5.0		5.0		5.0	5.0
Body Inclination	Δh	±2.0	0		0		0	0		0		0		0	0
Tape Width	W	±0.5	18.0		18.0		18.0	18.0		18.0		18.0		18.0	18.0
Adhesive Tape Width	W <sub>0</sub>	min.	9.5		9.5		9.5	9.5		9.5		9.5		9.5	12.5
Feeding Hole Alignment	W <sub>1</sub>	±0.5	9.0		9.0		9.0	9.0		9.0		9.0		9.0	9.0
Adhesive Tape Margin	W <sub>2</sub>	max.	2.0		2.0		2.0	2.0		2.0		2.0		2.0	2.0
Length from Seating Plane	H	±0.5	18.0		17.5		18.5	18.5 (5, 7mmL = 17.5)		17.5		20.0		17.5	20.0
Lead Clinch Height	H <sub>0</sub>	±0.5	17.0		—		—	16.5		16.5		16.5		16.5	16.5
Feeding Hole Dia.	ØD <sub>0</sub>	±0.2	4.0		4.0		4.0	4.0		4.0		4.0		4.0	4.0
Total Tape Thickness	t	±0.2	0.6		0.6		0.6	0.6		0.6		0.6		0.6	0.6
Cut Lead Height	A	max.	11.0		11.0		11.0	11.0		11.0		11.0		11.0	11.0
Taping Code	Ammo	⊕ leader	PC		PC		PE	PA		PA		PA		PA	PG

\* Note : Refer to the drawing of each series for tolerance.

MINIATURE TYPES

# TAPING

## ● Lead Taping Capacitors for Automatic Insertion

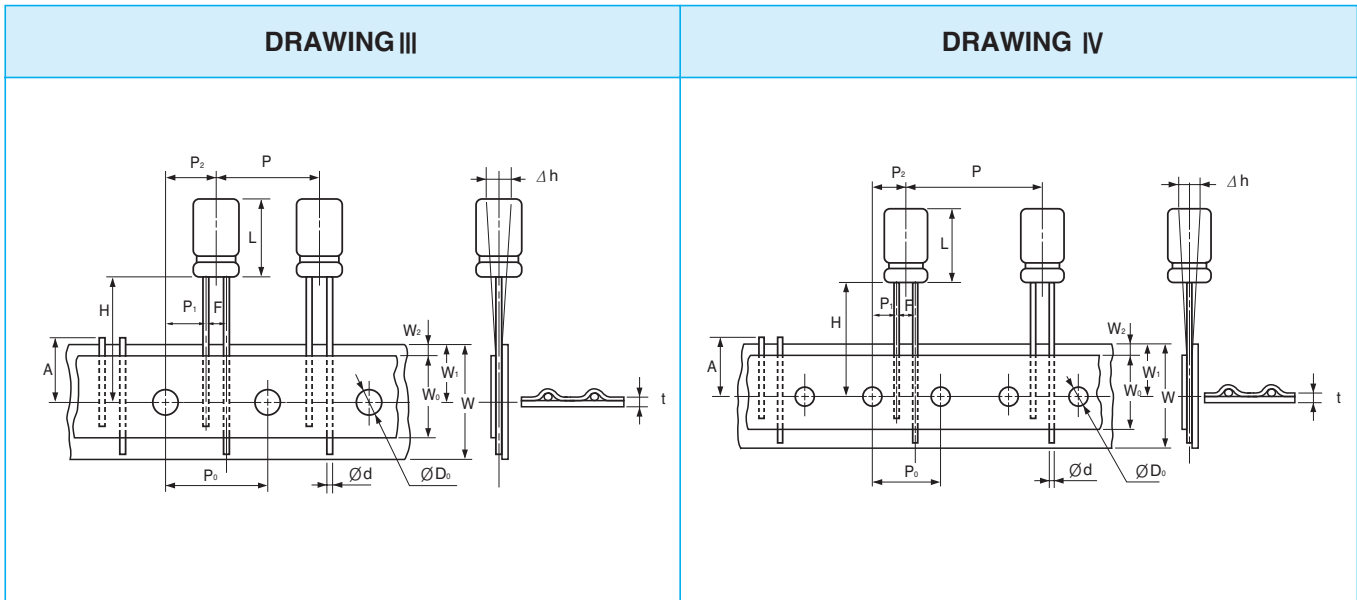

### ● DIMENSIONS

Unit : mm

Applicable Drawing No.			III	III	IV	IV	IV
Description	Symbol	Tolerance	Ø10	Ø12.5	Ø16	Ø18	Ø18
Case Height	L	max.	27.0	27.0	37.5	37.5	
Lead Dia.	Ød	±0.05	0.6	0.6	0.8	0.8	
Body Pitch	P	±1.0	12.7	15.0	25.4	30.0	30.0
Feeding Hole Pitch	P <sub>0</sub>	±0.2	12.7	15.0	12.7	15.0	15.0
Feeding Hole Alignment	P <sub>1</sub>	±0.7	3.85	5.0	3.85	3.75	3.75
Feeding Hole Alignment	P <sub>2</sub>	±1.0	6.35	7.5	6.35	7.5	7.5
Lead Center Spacing	F	+0.6 -0.2	5.0	5.0	7.5	7.5	
Body Inclination	Δh	±2.0	0	0	0	0	
Tape Width	W	±0.5	18.0	18.0	18.0	18.0	
Adhesive Tape Width	W <sub>0</sub>	min.	12.5	12.5	12.5	12.5	
Feeding Hole Alignment	W <sub>1</sub>	±0.5	9.0	9.0	9.0	9.0	
Adhesive Tape Margin	W <sub>2</sub>	max.	2.0	2.0	2.0	2.0	
Length from Seating Plane	H	±0.5	18.5	18.5	18.5	18.5	
Feeding Hole Dia.	ØD <sub>0</sub>	±0.2	4.0	4.0	4.0	4.0	
Total Tape Thickness	t	±0.2	0.6	0.7	0.7	0.7	
Cut Lead Height	A	max.	11.0	11.0	11.0	11.0	
Taping Code	Ammo	⊕ leader	PA	PH	PL	PA	PA

### ● PACKAGING Q'ty(pcs.)/Box

Unit : mm

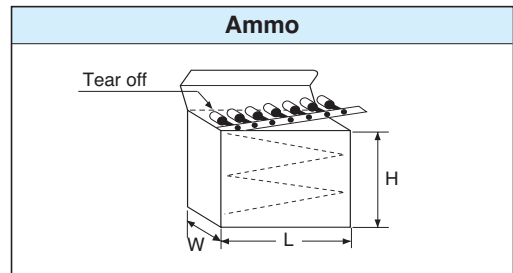

Size		Ammo			
ØD	Case Height	L	H	W	Q'ty
4	5, 7	332	230	42	2500
	11				
5	5, 7	332	230	49	2000
	11				
6.3	5, 7	332	230	42	1500
	11				
8	5, 7	332	230	42	1000
	11.5				
10	12.5, 16	332	190	51	500
	20, 25				
12.5	16, 20, 25	342	240	62	400
16	16, 20, 25	342	240	62	250
	31.5, 35.5				
18	16, 20, 25	342	240	62	200
	31.5, 35.5				

# MINIATURE ALUMINUM ELECTROLYTIC CAPACITORS



## SD Standard, For General Purposes Series

- Standard series for general purposes
- High voltage, high capacitance series
- Voltage range of 6.3~500V
- Complied to the RoHS directive

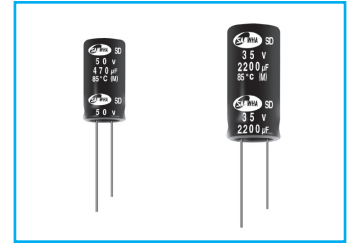

Item	Characteristics										
Operating temperature range	WV	6.3 ~ 450									
	Temperature range	-40 ~ +85°C									
Leakage current max.	WV ≤ 100	WV > 100									
	$I = 0.01CV$ or $3\mu A$ whichever is greater (after 2 min) $I = 0.03CV$ or $4\mu A$ whichever is greater (after 1 min)										
Capacitance tolerance	±20% at 120Hz, 20°C										
Dissipation factor max. (at 120Hz, 20°C)	Capacitance > 1000 $\mu F$ : $\tan\delta$ increases by 0.02 for each 1000 $\mu F$ from below value.										
	WV	6.3	10	16	25	35	50	63	100	160 ~ 250	350 ~ 500
$\tan\delta$	0.28	0.24	0.20	0.16	0.14	0.12	0.10	0.08	0.15	0.20	
Low temperature characteristics (Impedance ratio at 120Hz)	WV	6.3	10	16	25	35	50~100	160	200~350	400~450	500
	Z-25°C/Z+20°C	5	4	3	2	2	2	4	6	10	12
	Z-40°C/Z+20°C	12	10	8	5	4	3	6	8	12	—
Load life (after application of the rated voltage for 2000 hours at 85°C)	Leakage current	Less than specified value									
	Capacitance change	Within ±20% of initial value									
	$\tan\delta$	Less than 200% of specified value									
Shelf life (at 85°C)	After 1000 hours no load test, leakage current, capacitance and $\tan\delta$ are same as load life value. The measurement shall be performed at 20°C by the KS C IEC 60384 - 4										

### DRAWING

Unit : mm

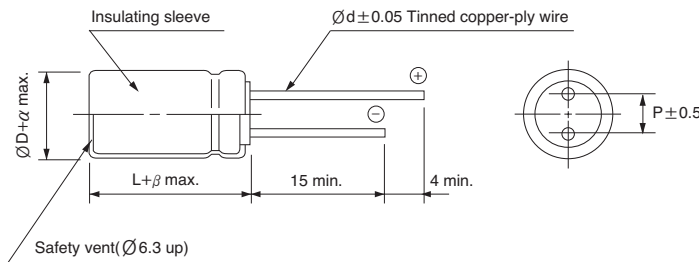

$\varnothing D$	5	6.3	8	10	12.5	16	18	22
P	2.0	2.5	3.5	5.0	5.0	7.5	7.5	10.0
$\varnothing d$	0.5	0.5	0.6	0.6	0.6	0.8	0.8	1.0
$\alpha$	0.5							1.0
$\beta$	1.5		2.0				3.0	

### FREQUENCY COEFFICIENT OF PERMISSIBLE RIPPLE CURRENT

WV	Frequency $\mu F$	60Hz	120Hz	1kHz	10kHz	50kHz	100kHz ≤
6.3~100	~ 47	0.75	1.00	1.55	2.00	2.00	2.00
	68 ~ 680	0.80	1.00	1.35	1.50	1.62	1.75
	1000 ~	0.85	1.00	1.15	1.15	1.32	1.50
160~500	~ 220	0.80	1.00	1.40	1.60	1.70	1.80
	330 ~	0.90	1.00	1.13	1.15	1.32	1.50



# MINIATURE ALUMINUM ELECTROLYTIC CAPACITORS

**SD** series

● DIMENSIONS & MAXIMUM PERMISSIBLE RIPPLE CURRENT

WV μF	6.3	10	16	25	35	50	63	100	160	200	250	350	400	450	500
1.0						5×11 21	5×11 23	5×11 23							
1.5						5×11 26	5×11 28	5×11 28						8×11.5 32	
2.2						5×11 32	5×11 34	5×11 34						8×11.5 33	
3.3						5×11 39	5×11 42	5×11 42	6.3×11 45	6.3×11 45	6.3×11 48	8×11.5 53	8×11.5 56	8×11.5 50	
4.7						5×11 46	5×11 50	5×11 50	6.3×11 53	6.3×11 57	6.3×11 57	8×11.5 66	10×12.5 73	10×12.5 72	10×16 69
6.8						5×11 56	5×11 60	5×11 60	8×11.5 76	8×11.5 76	8×11.5 76	10×12.5 88	10×12.5 87	10×16 86	10×16 76
10						5×11 68	5×11 72	5×11 76	8×11.5 96	8×11.5 96	10×12.5 107	10×12.5 107	10×16 115	10×20 115	12.5×25 178
15						5×11 83	5×11 89	6.3×11 89	10×12.5 131	10×16 143	10×16 143	10×20 156	12.5×20 165	12.5×20 164	
22						5×11 101	5×11 108	6.3×11 124	10×12.5 156	10×16 173	10×16 170	12.5×20 222	12.5×20 218	12.5×25 217	16×25 265
33						5×11 123	6.3×11 151	8×11.5 178	10×16 209	10×20 232	10×20 247	16×20 297	12.5×25 296	16×25 294	16×31.5 310
47					5×11 131	*6.3×11 169	6.3×11 181	8×11.5 222	10×20 293	10×20 293	12.5×20 319	16×20 353	16×25 387	16×31.5 384	18×31.5 412
68				5×11 144	*6.3×11 182	6.3×11 203	8×11.5 256	10×12.5 293	12.5×20 391	12.5×25 426	16×20 425	16×25 465	16×31.5 488	16×35.5 503	18×35.5 457
100			5×11 162	*5×11 181	6.3×11 220	8×11.5 291	8×11.5 311	10×16 388	12.5×25 516	16×25 516	16×25 564	18×31.5 592	18×35.5 667	18×40 546	
150			*5×11 198	6.3×11 246	8×11.5 318	10×12.5 414	10×12.5 422	10×20 528	16×20 632	16×25 691	16×31.5 726	18×40 845	18×40 863	22×45 1283	
220	5×11 201	*5×11 218	6.3×11 276	6.3×11 327	8×11.5 386	10×12.5 501	10×16 586	12.5×20 737	16×25 873	18×31.5 962	18×35.5 988	22×41 1112	22×45 1183		
330	*6.3×11 283	6.3×11 307	6.3×11 359	8×11.5 431	10×12.5 549	10×16 672	10×20 784	12.5×25 1002	16×35.5 1152	18×35.5 1206	22×41 1495				
470	6.3×11 338	6.3×11 366	8×11.5 476	10×12.5 550	10×16 740	10×20 875	12.5×20 1098	16×25 1328	18×40 1434	22×41 1495					
680	8×11.5 480	8×11.5 520	8×11.5 600	10×16 754	10×20 947	12.5×20 1235	12.5×25 1440	16×31.5 1643	22×41 1831						
1000	8×11.5 581	10×12.5 659	10×12.5 796	10×16 942	12.5×20 1306	12.5×25 1633	16×25 1937	18×31.5 1965							
2200	10×16 983	10×16 1051	10×20 1331	12.5×20 1542	16×25 2032	16×31.5 2220	18×31.5 2445								
3300	10×20 1286	12.5×20 1545	12.5×20 1686	16×25 2194	16×31.5 2502	18×31.5 2765	18×40 2987								
4700	12.5×20 1736	12.5×25 1903	12.5×25 2129	16×25 2448	16×35.5 2905	18×40 3272									
6800	12.5×25 2129	16×25 2332	16×25 2577	18×31.5 3114	18×40 3408	← Case size $\varnothing D \times L$ (mm) ← Ripple current (mA rms) at 85°C, 120Hz									
10000	16×25 2629	16×31.5 2830	16×31.5 3176	18×40 3544											
15000	16×35.5 2959	16×35.5 3284	18×35.5 3656												
22000	18×40 3733	18×40 3843	22×41 4012												

# MINIATURE ALUMINUM ELECTROLYTIC CAPACITORS



## SS Standard, Height 7mmL Series

- Super miniature series with 7mmL height
- Suited for use in compact audio equipment
- Load life of 2000 hours at 85°C
- Complied to the RoHS directive

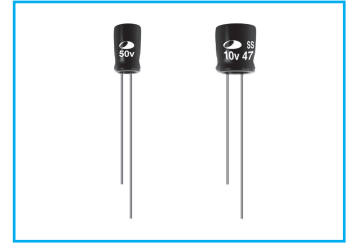
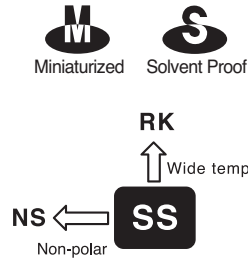

Item	Characteristics																		
Operating temperature range	-40 ~ +85°C																		
Leakage current max.	$I = 0.01CV$ or $4\mu A$ whichever is greater (after 1 minute)																		
Capacitance tolerance	$\pm 20\%$ at 120Hz, 20°C																		
Dissipation factor max. (at 120Hz, 20°C)	<table border="1"> <tr> <td>WV</td> <td>4</td> <td>6.3</td> <td>10</td> <td>16</td> <td>25</td> <td>35, 40</td> <td>50</td> <td>63</td> </tr> <tr> <td><math>\tan\delta</math></td> <td>0.35</td> <td>0.24</td> <td>0.20</td> <td>0.16</td> <td>0.14</td> <td>0.12</td> <td>0.10</td> <td>0.10</td> </tr> </table>	WV	4	6.3	10	16	25	35, 40	50	63	$\tan\delta$	0.35	0.24	0.20	0.16	0.14	0.12	0.10	0.10
WV	4	6.3	10	16	25	35, 40	50	63											
$\tan\delta$	0.35	0.24	0.20	0.16	0.14	0.12	0.10	0.10											
Low temperature characteristics (Impedance ratio at 120Hz)	<table border="1"> <tr> <td>WV</td> <td>4</td> <td>6.3</td> <td>10</td> <td>16, 25</td> <td>35 ~ 63</td> </tr> <tr> <td>Z-25°C/Z+20°C</td> <td>6</td> <td>4</td> <td>3</td> <td>2</td> <td>2</td> </tr> <tr> <td>Z-40°C/Z+20°C</td> <td>12</td> <td>8</td> <td>6</td> <td>4</td> <td>3</td> </tr> </table>	WV	4	6.3	10	16, 25	35 ~ 63	Z-25°C/Z+20°C	6	4	3	2	2	Z-40°C/Z+20°C	12	8	6	4	3
WV	4	6.3	10	16, 25	35 ~ 63														
Z-25°C/Z+20°C	6	4	3	2	2														
Z-40°C/Z+20°C	12	8	6	4	3														
Load life (after application of the rated voltage for 2000 hours at 85°C)	<table border="1"> <tr> <td>Leakage current</td> <td>Less than specified value</td> </tr> <tr> <td>Capacitance change</td> <td>Within <math>\pm 20\%</math> of initial value</td> </tr> <tr> <td><math>\tan\delta</math></td> <td>Less than 200% of specified value</td> </tr> </table>	Leakage current	Less than specified value	Capacitance change	Within $\pm 20\%$ of initial value	$\tan\delta$	Less than 200% of specified value												
Leakage current	Less than specified value																		
Capacitance change	Within $\pm 20\%$ of initial value																		
$\tan\delta$	Less than 200% of specified value																		
Shelf life (at 85°C)	After 1000 hours no load test, leakage current, capacitance and $\tan\delta$ are same as load life value. The measurement shall be performed at 20°C by the KS C IEC 60384 - 4																		

### ● DRAWING (See page 96)

### ● DIMENSIONS & MAXIMUM PERMISSIBLE RIPPLE CURRENT

$\mu F$ \ WV	4	6.3	10	16	25	35	40	50	63
1.0								4×7 14	4×7 14
1.5								4×7 17	4×7 17
2.2								4×7 21	4×7 21
3.3								4×7 25	4×7 25
4.7								4×7 30	4×7 30
6.8						4×7 33	4×7 33	4×7 37	5×7 42
10					4×7 37	4×7 40	4×7 40	5×7 51	5×7 51
15				4×7 43	4×7 46	5×7 57	5×7 57	6.3×7 72	6.3×7 72
22			4×7 46	4×7 52	5×7 64	5×7 69	6.3×7 80	6.3×7 88	
33	4×7 43	4×7 52	4×7 57	5×7 73	5×7 78	6.3×7 98	6.3×7 98		
47	4×7 51	4×7 62	5×7 78	5×7 87	6.3×7 108				
68	5×7 71	5×7 86	5×7 94	6.3×7 122					
100	5×7 86	5×7 104	6.3×7 132	6.3×7 148					
150	6.3×7 122	6.3×7 148	6.3×7 162						
220	6.3×7 148	6.3×7 179							

↑ Ripple current (mA rms) at 85°C, 120Hz  
 — Case size  $\varnothing D \times L$  (mm)

### ● FREQUENCY COEFFICIENT OF PERMISSIBLE RIPPLE CURRENT

$\mu F$ \ Frequency	60Hz	120Hz	1kHz	10kHz	50kHz	100kHz ≤
~ 47	0.75	1.00	1.55	2.00	2.00	2.00
68 ~	0.80	1.00	1.35	1.50	1.62	1.75

# MINIATURE ALUMINUM ELECTROLYTIC CAPACITORS

**SE** Standard, Height 5mmL Series

- Ultra miniature series with 5mmL height
- Suitable to replace tantalum capacitors at low cost
- Load life of 2000 hours at 85°C
- Complied to the RoHS directive

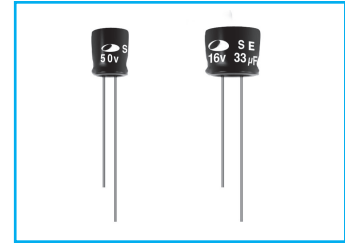
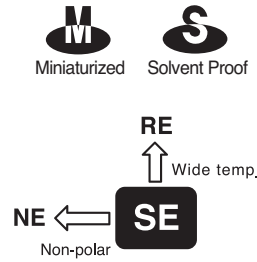

Item	Characteristics																		
Operating temperature range	-40 ~ +85°C																		
Leakage current max.	$I = 0.01CV$ or $4\mu A$ whichever is greater (after 1 minute)																		
Capacitance tolerance	$\pm 20\%$ at 120Hz, 20°C																		
Dissipation factor max. (at 120Hz, 20°C)	<table border="1"> <tr> <td>WV</td> <td>4</td> <td>6.3</td> <td>10</td> <td>16</td> <td>25</td> <td>35</td> <td>50</td> <td>63</td> </tr> <tr> <td><math>\tan\delta</math></td> <td>0.35</td> <td>0.24</td> <td>0.20</td> <td>0.16</td> <td>0.13</td> <td>0.12</td> <td>0.09</td> <td>0.09</td> </tr> </table>	WV	4	6.3	10	16	25	35	50	63	$\tan\delta$	0.35	0.24	0.20	0.16	0.13	0.12	0.09	0.09
	WV	4	6.3	10	16	25	35	50	63										
$\tan\delta$	0.35	0.24	0.20	0.16	0.13	0.12	0.09	0.09											
Low temperature characteristics (Impedance ratio at 120Hz)	<table border="1"> <tr> <td>WV</td> <td>4</td> <td>6.3</td> <td>10</td> <td>16 ~ 63</td> </tr> <tr> <td>Z-25°C/Z+20°C</td> <td>6</td> <td>4</td> <td>3</td> <td>2</td> </tr> <tr> <td>Z-40°C/Z+20°C</td> <td>12</td> <td>8</td> <td>6</td> <td>4</td> </tr> </table>	WV	4	6.3	10	16 ~ 63	Z-25°C/Z+20°C	6	4	3	2	Z-40°C/Z+20°C	12	8	6	4			
	WV	4	6.3	10	16 ~ 63														
	Z-25°C/Z+20°C	6	4	3	2														
Z-40°C/Z+20°C	12	8	6	4															
Load life (after application of the rated voltage for 2000 hours at 85°C)	<table border="1"> <tr> <td>Leakage current</td> <td>Less than specified value</td> </tr> <tr> <td>Capacitance change</td> <td>Within <math>\pm 20\%</math> of initial value</td> </tr> <tr> <td><math>\tan\delta</math></td> <td>Less than 200% of specified value</td> </tr> </table>	Leakage current	Less than specified value	Capacitance change	Within $\pm 20\%$ of initial value	$\tan\delta$	Less than 200% of specified value												
	Leakage current	Less than specified value																	
	Capacitance change	Within $\pm 20\%$ of initial value																	
$\tan\delta$	Less than 200% of specified value																		
Shelf life (at 85°C)	After 1000 hours no load test, leakage current, capacitance and $\tan\delta$ are same as load life value. The measurement shall be performed at 20°C by the KS C IEC 60384 - 4																		

● DRAWING (See page 97)

● DIMENSIONS & MAXIMUM PERMISSIBLE RIPPLE CURRENT

$\mu F$ \ WV	4	6.3	10	16	25	35	50	63								
1.0							4×5	13	4×5	13						
1.5							4×5	16	4×5	16						
2.2						4×5	17	4×5	19	4×5	19					
3.3					4×5	20	4×5	20	4×5	24	5×5	27				
4.7				4×5	21	4×5	23	4×5	24	5×5	33	5×5	33			
6.8			4×5	23	4×5	25	4×5	28	5×5	34	5×5	39	6.3×5	46		
10	4×5	21	4×5	25	4×5	28	4×5	31	5×5	40	5×5	41	6.3×5	56	6.3×5	56
15	4×5	26	4×5	31	4×5	34	5×5	44	5×5	49	6.3×5	59	6.3×5	68	8×5	81
22	4×5	31	4×5	37	5×5	47	5×5	53	6.3×5	69	6.3×5	72	8×5	98	8×5	98
33	4×5	38	5×5	53	5×5	58	6.3×5	76	6.3×5	84	8×5	104	8×5	120		
47	4×5	45	5×5	63	6.3×5	81	6.3×5	91	8×5	119	8×5	124				
68	5×5	63	6.3×5	89	6.3×5	98	6.3×5	109	8×5	143						
100	5×5	89	6.3×5	108	8×5	140	8×5	157	8×5	174						
150	6.3×5	109	8×5	157	8×5	172	8×5	192								
220	6.3×5	133	8×5	190	8×5	208										
330	8×5	192														

↑ ↑  
Ripple current (mA rms) at 85°C, 120Hz  
Case size  $\varnothing D \times L$  (mm)

● FREQUENCY COEFFICIENT OF PERMISSIBLE RIPPLE CURRENT

$\mu F$ \ Frequency	60Hz	120Hz	1kHz	10kHz	50kHz	100kHz $\leq$
~ 47	0.75	1.00	1.55	2.00	2.00	2.00
68 ~	0.80	1.00	1.35	1.50	1.62	1.75

## RD Wide Temperature Range Series

- Standard series for general purpose
- High CV value
- Wide operating temperature range of -55 ~ +105°C
- Complied to the RoHS directive

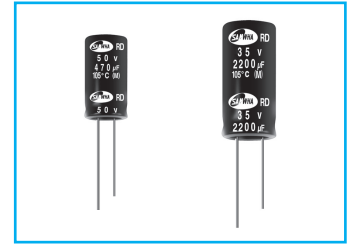
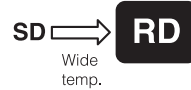

Item	Characteristics											
Operating temperature range	WV	6.3 ~ 100				160 ~ 450				500		
	Temperature range	-55 ~ +105°C				-40 ~ +105°C				-25 ~ +105°C		
Leakage current max.	WV ≤ 100						WV > 100					
	I = 0.01CV or 3µA whichever is greater (after 2 min) I = 0.03CV or 4µA whichever is greater (after 1 min)						I = 0.02CV + 15µA (after 5 min)					
Capacitance tolerance	±20% at 120Hz, 20°C											
Dissipation factor max. (at 120Hz, 20°C)	Capacitance > 1000µF : tanδ increases by 0.02 for each 1000µF from below value.											
	WV	6.3	10	16	25	35	50	63	100	160~250	350~500	
tanδ	0.28	0.24	0.20	0.16	0.14	0.12	0.10	0.08	0.15	0.20		
Low temperature characteristics (Impedance ratio at 120Hz)	WV	6.3	10	16	25	35	50~100	160	200~350	400~450	500	
	Z-25°C/Z+20°C	5	4	3	2	2	2	4	6	10	12	
	Z-40°C/Z+20°C	12	10	8	5	4	3	6	8	12	-	
Load life (after application of the rated voltage for 2000 hours at 105°C)	Leakage current	Less than specified value										
	Capacitance change	Within ±20% of initial value										
	tanδ	Less than 200% of specified value										
	Life time	∅D ≤ 8			∅D ≥ 10							
Shelf life (at 105°C)	After 1000 hours no load test, leakage current, capacitance and tanδ are same as load life value. The measurement shall be performed at 20°C by the KS C IEC 60384 - 4											

### DRAWING

Unit : mm

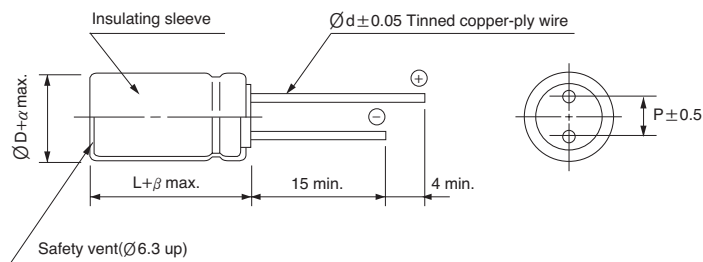

∅D	5	6.3	8	10	12.5	16	18	22
P	2.0	2.5	3.5	5.0	5.0	7.5	7.5	10.0
∅d	0.5	0.5	0.6	0.6	0.6	0.8	0.8	1.0
α	0.5							1.0
β	1.5		2.0				3.0	

### FREQUENCY COEFFICIENT OF PERMISSIBLE RIPPLE CURRENT

WV	µF	Frequency	60Hz	120Hz	1kHz	10kHz	50kHz	100kHz ≤
6.3~100		~ 47	0.75	1.00	1.55	2.00	2.00	2.00
		68 ~ 680	0.80	1.00	1.35	1.50	1.62	1.75
		820 ~	0.85	1.00	1.15	1.15	1.32	1.50
160~500		~ 220	0.80	1.00	1.40	1.60	1.70	1.80
		330 ~	0.90	1.00	1.13	1.15	1.32	1.50

# MINIATURE ALUMINUM ELECTROLYTIC CAPACITORS

**RD** series

● DIMENSIONS & MAXIMUM PERMISSIBLE RIPPLE CURRENT

WV Item μF	6.3		10		16		25	
	∅D×L (mm)	Ripple current (mA rms) 105°C 120Hz	∅D×L (mm)	Ripple current (mA rms) 105°C 120Hz	∅D×L (mm)	Ripple current (mA rms) 105°C 120Hz	∅D×L (mm)	Ripple current (mA rms) 105°C 120Hz
68							5 × 11	108
82							6.3 × 11	137
100					5 × 11	119	6.3 × 11	151
150			5 × 11	134	6.3 × 11	167	6.3 × 11	185
220	5 × 11	146	5 × 11	162	6.3 × 11	203	6.3 × 11	224
330	6.3 × 11	206	6.3 × 11	228	6.3 × 11	248	8 × 11.5	324
470	6.3 × 11	246	6.3 × 11	272	8 × 11.5	349	8 × 11.5	386
680	8 × 11.5	348	8 × 11.5	386	8 × 11.5	420	10 × 12.5	540
820	8 × 11.5	382	10 × 12.5	493	10 × 16	587	10 × 20	708
1000	8 × 11.5	422	10 × 12.5	544	10 × 16	648	10 × 20	820
1500	10 × 16	621	10 × 16	680	10 × 20	797	12.5 × 20	1017
2200	10 × 16	713	10 × 16	774	10 × 20	898	12.5 × 20	1100
	10 × 20	778	10 × 20	844	12.5 × 20	1055	12.5 × 25	1235
3300	12.5 × 16	983	12.5 × 20	1148	12.5 × 20	1184	16 × 25	1562
4700	12.5 × 20	1219	12.5 × 20	1272	12.5 × 25	1459	16 × 25	1752
			12.5 × 25	1421	16 × 25	1657	16 × 31.5	1916
6800	12.5 × 25	1480	16 × 25	1737	16 × 25	1811	16 × 35.5	2176
					16 × 31.5	1982	18 × 35.5	2335
10000	16 × 25	1807	16 × 31.5	2172	16 × 31.5	2140	18 × 35.5	2497
15000	16 × 31.5	2128	16 × 35.5	2323	18 × 35.5	2545		
	16 × 35.5	2233	18 × 35.5	2482				
22000	18 × 31.5	2411						

WV Item μF	35		50		63		100	
	∅D×L (mm)	Ripple current (mA rms) 105°C 120Hz	∅D×L (mm)	Ripple current (mA rms) 105°C 120Hz	∅D×L (mm)	Ripple current (mA rms) 105°C 120Hz	∅D×L (mm)	Ripple current (mA rms) 105°C 120Hz
2.2			5 × 11	24	5 × 11	26		
3.3			5 × 11	29	5 × 11	32	5 × 11	32
4.7			5 × 11	35	5 × 11	38	5 × 11	38
6.8			5 × 11	42	5 × 11	46	5 × 11	46
10			5 × 11	51	5 × 11	56	5 × 11	56
15			5 × 11	62	5 × 11	68	6.3 × 11	78
22			5 × 11	75	5 × 11	83	6.3 × 11	95
33			5 × 11	92	6.3 × 11	116	8 × 11.5	139
47	5 × 11	96	6.3 × 11	127	6.3 × 11	139	10 × 12.5	190
68	6.3 × 11	132	8 × 11.5	180	8 × 11.5	197	10 × 16	251
82	6.3 × 11	145	8 × 11.5	198	8 × 11.5	216	10 × 16	290
100	6.3 × 11	160	8 × 11.5	218	8 × 11.5	239	10 × 16	304
150	8 × 11.5	231	8 × 11.5	267	10 × 12.5	340	10 × 20	406
220	8 × 11.5	280	10 × 12.5	376	10 × 16	451	12.5 × 20	564
330	10 × 12.5	400	10 × 16	504	10 × 20	603	16 × 25	856
470	10 × 16	521	10 × 20	657	12.5 × 20	844	16 × 25	1021
680	10 × 20	684	12.5 × 20	927	12.5 × 25	1107	16 × 31.5	1344
820	12.5 × 20	880	12.5 × 25	1050	16 × 25	1300	16 × 35.5	1627
1000	12.5 × 20	974	12.5 × 25	1226	16 × 25	1490	18 × 35.5	1835
1500	12.5 × 25	1136	16 × 25	1442	16 × 35.5	1770		
	16 × 20	1188	16 × 31.5	1578	18 × 31.5	1812		
2200	16 × 25	1426	16 × 31.5	1709	16 × 35.5	1891		
3300	16 × 35.5	1857	16 × 35.5	1794	18 × 40	2689		
	18 × 31.5	1900	18 × 35.5	2152				
4700	16 × 35.5	2073						
	18 × 35.5	2224						
6800	18 × 40	2510						

## RD series

### ● DIMENSIONS & MAXIMUM PERMISSIBLE RIPPLE CURRENT

WV Item $\mu$ F	160		200		250		350	
	$\varnothing D \times L$ (mm)	Ripple current (mA rms) 105°C 120Hz	$\varnothing D \times L$ (mm)	Ripple current (mA rms) 105°C 120Hz	$\varnothing D \times L$ (mm)	Ripple current (mA rms) 105°C 120Hz	$\varnothing D \times L$ (mm)	Ripple current (mA rms) 105°C 120Hz
2.2	6.3 × 11	23	6.3 × 11	23	6.3 × 11	23	6.3 × 11	23
3.3	6.3 × 11	29	6.3 × 11	29	6.3 × 11	30	8 × 11.5	34
4.7	6.3 × 11	34	6.3 × 11	34	8 × 11.5	40	8 × 11.5	40
			8 × 11.5	40			10 × 12.5	47
6.8	6.3 × 11	41	8 × 11.5	49	10 × 12.5	56	10 × 12.5	56
			10 × 12.5	56			10 × 16	62
10	8 × 11.5	59	8 × 11.5	59	10 × 12.5	68	10 × 16	75
	10 × 12.5	68	10 × 12.5	68			10 × 16	92
15	10 × 12.5	84	10 × 12.5	84	10 × 16	92	10 × 16	92
	10 × 16	92	10 × 16	92			10 × 20	100
22	10 × 12.5	102	10 × 16	111	10 × 16	111	12.5 × 20	143
	10 × 16	111			10 × 20	121		
33	10 × 16	136	10 × 20	149	10 × 20	149	12.5 × 25	190
	10 × 20	149			12.5 × 20	175		
47	10 × 20	177	12.5 × 20	208	12.5 × 20	203	16 × 25	252
	12.5 × 20	208			12.5 × 25	227		
68	12.5 × 25	273	16 × 20	279	12.5 × 25	267	16 × 31.5	332
82	12.5 × 25	302	16 × 25	333	16 × 25	333	18 × 31.5	391
100	12.5 × 25	331	16 × 25	368	16 × 25	368	18 × 31.5	432
150	16 × 25	450	16 × 25	450	16 × 31.5	450	18 × 35.5	554
220	16 × 31.5	596	18 × 31.5	641	18 × 35.5	671	22 × 41	721
			18 × 35.5	671	18 × 40	694		
330	18 × 31.5	784	18 × 40	863	22 × 41	968		
470	18 × 40	1030	22 × 41	1155				
680	22 × 41	1390						

WV Item $\mu$ F	400		450		500	
	$\varnothing D \times L$ (mm)	Ripple current (mA rms) 105°C 120Hz	$\varnothing D \times L$ (mm)	Ripple current (mA rms) 105°C 120Hz	$\varnothing D \times L$ (mm)	Ripple current (mA rms) 105°C 120Hz
2.2	8 × 11.5	28	8 × 11.5	23		
3.3	8 × 11.5	34	10 × 12.5	33		
	10 × 12.5	39	10 × 16	36		
4.7	10 × 12.5	47	10 × 12.5	39	10 × 16	59
6.8	10 × 16	62	10 × 16	52	10 × 16	72
10	10 × 16	75	10 × 20	68	12.5 × 25	88
	10 × 20	82	12.5 × 20	80		
15	12.5 × 20	118	12.5 × 20	96	12.5 × 30	115
22	12.5 × 20	140	12.5 × 25	127	16 × 25	159
	12.5 × 25	155	16 × 25	144		
33	16 × 25	211	16 × 25	177	16 × 31.5	207
47	16 × 25	252	16 × 31.5	231	18 × 31.5	261
68	16 × 31.5	332	16 × 35.5	291	18 × 35.5	335
	18 × 31.5	356				
82	18 × 31.5	391	18 × 31.5	327	18 × 40	370
100	18 × 35.5	453	18 × 40	420		
150	22 × 41	596				

# MINIATURE ALUMINUM ELECTROLYTIC CAPACITORS

## RK Wide Temperature Range, Height 7mmL Series

- Super miniature series with 7mmL height
- High performance and excellent temperature characteristics
- Wide operating temperature range of -55 ~ +105°C
- Complied to the RoHS directive

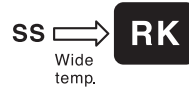
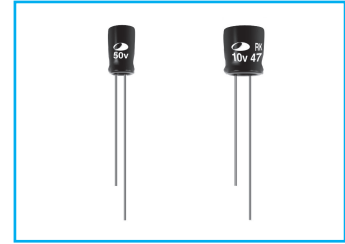

Item	Characteristics																					
Operating temperature range	-55 ~ +105°C																					
Leakage current max.	$I = 0.01CV$ or $3\mu A$ whichever is greater (after 1 minute)																					
Capacitance tolerance	$\pm 20\%$ at 120Hz, 20°C																					
Dissipation factor max. (at 120Hz, 20°C)	<table border="1"> <tr> <td>WV</td> <td>4</td> <td>6.3</td> <td>10</td> <td>16</td> <td>25</td> <td>35</td> <td>50</td> <td>63</td> </tr> <tr> <td><math>\tan\delta</math></td> <td>0.35</td> <td>0.22</td> <td>0.19</td> <td>0.15</td> <td>0.12</td> <td>0.12</td> <td>0.10</td> <td>0.10</td> </tr> </table>	WV	4	6.3	10	16	25	35	50	63	$\tan\delta$	0.35	0.22	0.19	0.15	0.12	0.12	0.10	0.10			
	WV	4	6.3	10	16	25	35	50	63													
$\tan\delta$	0.35	0.22	0.19	0.15	0.12	0.12	0.10	0.10														
Low temperature characteristics (Impedance ratio at 120Hz)	<table border="1"> <tr> <td>WV</td> <td>4</td> <td>6.3</td> <td>10</td> <td>16</td> <td>25, 35</td> <td>50, 63</td> </tr> <tr> <td>Z-25°C/Z+20°C</td> <td>6</td> <td>4</td> <td>3</td> <td>2</td> <td>2</td> <td>2</td> </tr> <tr> <td>Z-40°C/Z+20°C</td> <td>12</td> <td>10</td> <td>8</td> <td>6</td> <td>4</td> <td>3</td> </tr> </table>	WV	4	6.3	10	16	25, 35	50, 63	Z-25°C/Z+20°C	6	4	3	2	2	2	Z-40°C/Z+20°C	12	10	8	6	4	3
	WV	4	6.3	10	16	25, 35	50, 63															
	Z-25°C/Z+20°C	6	4	3	2	2	2															
Z-40°C/Z+20°C	12	10	8	6	4	3																
Load life (after application of the rated voltage for 1000 hours at 105°C)	Leakage current	Less than specified value																				
	Capacitance change	Within $\pm 20\%$ of initial value																				
	$\tan\delta$	Less than 200% of specified value																				
Shelf life (at 105°C)	After 1000 hours no load test, leakage current, capacitance and $\tan\delta$ are same as load life value. The measurement shall be performed at 20°C by the KS C IEC 60384 - 4																					

### DRAWING

Unit : mm

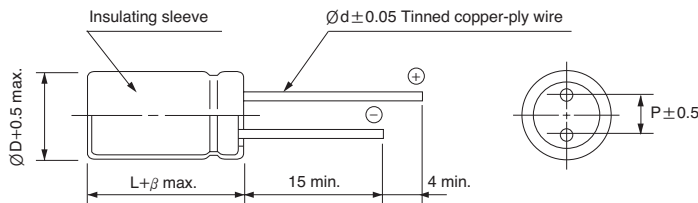

ØD	4	5	6.3
P	1.5	2.0	2.5
Ød	0.45	0.5	0.5
β	1.0	1.5	1.5

### DIMENSIONS & MAXIMUM PERMISSIBLE RIPPLE CURRENT

µF	WV	4	6.3	10	16	25	35	50	63				
1.0								4×7	9.1	4×7	9.1		
2.2								4×7	14	5×7	16		
3.3							4×7	15	5×7	19	6.3×7	22	
4.7						4×7	18	5×7	21	6.3×7	26	6.3×7	26
6.8					4×7	19	5×7	25	5×7	25	6.3×7	32	
10				4×7	21	4×7	24	5×7	30	6.3×7	35		
22			4×7	29	5×7	36	5×7	40	6.3×7	52			
33	4×7	28	5×7	40	6.3×7	51	6.3×7	57					
47	4×7	33	5×7	47	6.3×7	60							
68	5×7	46	6.3×7	67									

Ripple current (mA rms) at 105°C, 120Hz  
Case size ØD×L (mm)

### FREQUENCY COEFFICIENT OF PERMISSIBLE RIPPLE CURRENT

µF	Frequency	60Hz	120Hz	1kHz	10kHz	50kHz	100kHz ≤
~ 47		0.75	1.00	1.55	2.00	2.00	2.00
68 ~		0.80	1.00	1.35	1.50	1.62	1.75

# MINIATURE ALUMINUM ELECTROLYTIC CAPACITORS



## RE Wide Temperature Range, Height 5mmL Series

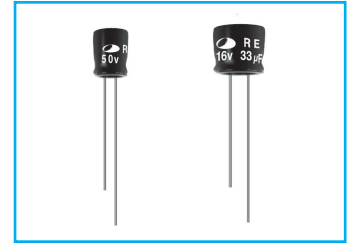
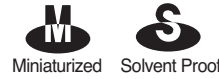

- Ultra miniature series with 5mmL height
- Wide operating temperature range of -55 ~ +105°C
- Suitable to replace tantalum capacitors at low cost
- Complied to the RoHS directive

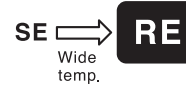

Item	Characteristics																		
Operating temperature range	-55 ~ +105°C																		
Leakage current max.	$I = 0.01CV$ or $3\mu A$ whichever is greater (after 2 minutes)																		
Capacitance tolerance	$\pm 20\%$ at 120Hz, 20°C																		
Dissipation factor max. (at 120Hz, 20°C)	<table border="1"> <tr> <td>WV</td> <td>4</td> <td>6.3</td> <td>10</td> <td>16</td> <td>25</td> <td>35</td> <td>50</td> </tr> <tr> <td>tan<math>\delta</math></td> <td>0.35</td> <td>0.27</td> <td>0.23</td> <td>0.19</td> <td>0.15</td> <td>0.13</td> <td>0.11</td> </tr> </table>	WV	4	6.3	10	16	25	35	50	tan $\delta$	0.35	0.27	0.23	0.19	0.15	0.13	0.11		
	WV	4	6.3	10	16	25	35	50											
tan $\delta$	0.35	0.27	0.23	0.19	0.15	0.13	0.11												
Low temperature characteristics (Impedance ratio at 120Hz)	<table border="1"> <tr> <td>WV</td> <td>4</td> <td>6.3</td> <td>10</td> <td>16</td> <td>25~50</td> </tr> <tr> <td>Z-25°C/Z+20°C</td> <td>7</td> <td>3</td> <td>3</td> <td>2</td> <td>2</td> </tr> <tr> <td>Z-40°C/Z+20°C</td> <td>12</td> <td>8</td> <td>5</td> <td>4</td> <td>3</td> </tr> </table>	WV	4	6.3	10	16	25~50	Z-25°C/Z+20°C	7	3	3	2	2	Z-40°C/Z+20°C	12	8	5	4	3
	WV	4	6.3	10	16	25~50													
	Z-25°C/Z+20°C	7	3	3	2	2													
Z-40°C/Z+20°C	12	8	5	4	3														
Load life (after application of the rated voltage for 1000 hours at 105°C)	Leakage current	Less than specified value																	
	Capacitance change	Within $\pm 25\%$ of initial value																	
	tan $\delta$	Less than 200% of specified value																	
Shelf life (at 105°C)	After 1000 hours no load test, leakage current, capacitance and tan $\delta$ are same as load life value. The measurement shall be performed at 20°C by the KS C IEC 60384 - 4																		

### DRAWING

Unit : mm

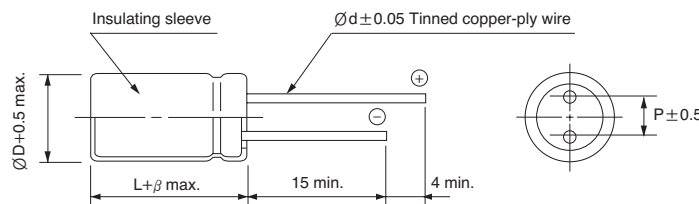

ØD	4	5	6.3	8
P	1.5	2.0	2.5	2.5
Ød	0.45	0.45	0.45	0.45
β	1.0	1.5		

### DIMENSIONS & MAXIMUM PERMISSIBLE RIPPLE CURRENT

µF \ WV	4	6.3	10	16	25	35	50
1.0							4×5 7.7
1.5							4×5 9.4
2.2							4×5 11
3.3						4×5	13 4×5 14
4.7					4×5	14	4×5 15 5×5 19
6.8					4×5	17	5×5 21 5×5 23
10		4×5 15	4×5 17	4×5 18	5×5 24	5×5 26	6.3×5 33
15	4×5 17	4×5 19	4×5 21	5×5 26	5×5 29	6.3×5 37	6.3×5 40
22	4×5 20	4×5 23	5×5 29	5×5 32	6.3×5 42	6.3×5 45	8×5 58
33	4×5 25	5×5 32	5×5 35	6.3×5 45	6.3×5 51	8×5 65	8×5 71
47	4×5 29	5×5 39	6.3×5 49	6.3×5 54	8×5 72	8×5 77	
68	5×5 41	6.3×5 55	6.3×5 59	8×5 77	8×5 87		
100	5×5 50	6.3×5 66	8×5 85	8×5 93			
150	6.3×5 71	8×5 96	8×5 104				
220	8×5 102	8×5 116					

↑ ↑  
Ripple current (mA rms) at 105°C, 120Hz  
Case size ØD×L (mm)

### FREQUENCY COEFFICIENT OF PERMISSIBLE RIPPLE CURRENT

µF \ Frequency	60Hz	120Hz	1kHz	10kHz	50kHz	100kHz ≤
~ 47	0.75	1.00	1.55	2.00	2.00	2.00
68 ~	0.80	1.00	1.35	1.50	1.62	1.75



# MINIATURE ALUMINUM ELECTROLYTIC CAPACITORS

**ZE** High Ripple Current, Height 5mmL Series

**M** Miniaturized **S** Solvent Proof **IZI** Low Impedance

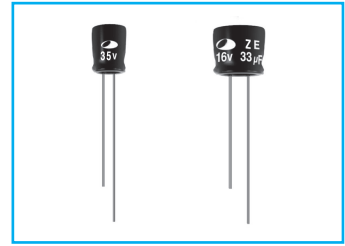

- Super miniature series with 5mmL height
- High ripple current & high temperature with RE series
- Load life of 2000 hours at 105°C
- Complied to the RoHS directive

RE → **ZE**  
High Ripple

Item	Characteristics					
Operating temperature range	-55 ~ +105°C					
Leakage current	I = 0.01CV or 3µA whichever is greater (after 2 minutes) I = 0.03CV or 4µA whichever is greater (after 1 minute)					
Capacitance tolerance	±20% at 120Hz, 20°C					
Dissipation factor max. (at 120Hz, 20°C)	WV	6.3	10	16	25	35
	tanδ	0.22	0.20	0.18	0.14	0.12
Low temperature characteristics (Impedance ratio at 120Hz)	WV	6.3	10	16	25	35
	Z-25°C / Z+20°C	3	3	2	2	2
	Z-40°C / Z+20°C	9	7	5	3	3
Load life	After an application of DC bias voltage plus the rated AC ripple current for 2000 hours at 105°C. The measurement shall meet the following limits. The DC voltage plus the peak AC voltage combined must not exceed the rated voltage.					
	Leakage current	Less than specified value				
	Capacitance change	Within ±20% of the initial value				
	tanδ	Less than 200% of the specified value				
Shelf life (at 105°C)	After 1000 hours no load test, leakage current, capacitance and tanδ are same as load life value. The measurement shall be performed at 20°C by the KS C IEC 60384 - 4					

## ● DRAWING

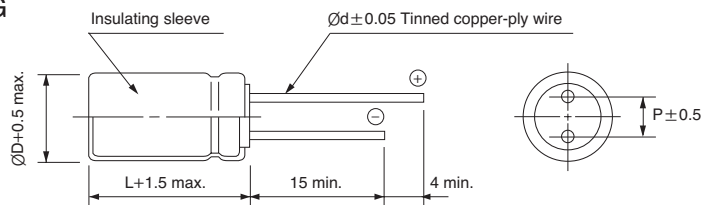

Unit : mm

ØD	5	6.3
P	2.0	2.5
Ød	0.45	0.45

## ● DIMENSIONS & MAXIMUM PERMISSIBLE RIPPLE CURRENT

WV Item µF	6.3			10			16			25			35		
	ØD×L (mm)	Imp.(Ω) max. 20°C 100kHz	Ripple current (mA rms) 105°C 100kHz	ØD×L (mm)	Imp.(Ω) max. 20°C 100kHz	Ripple current (mA rms) 105°C 100kHz	ØD×L (mm)	Imp.(Ω) max. 20°C 100kHz	Ripple current (mA rms) 105°C 100kHz	ØD×L (mm)	Imp.(Ω) max. 20°C 100kHz	Ripple current (mA rms) 105°C 100kHz	ØD×L (mm)	Imp.(Ω) max. 20°C 100kHz	Ripple current (mA rms) 105°C 100kHz
1													5×5	2.40	100
1.5													5×5	2.40	100
2.2													5×5	2.40	100
3.3													5×5	2.40	100
4.7													5×5	2.40	100
6.8													5×5	2.40	100
10									5×5	2.40	100	5×5	2.40	100	
15							5×5	2.40	100	5×5	2.40	100	5×5	2.40	100
22							5×5	2.40	100	5×5	2.40	100	6.3×5	0.75	140
33	5×5	2.40	100	5×5	2.40	100	5×5	2.40	100	6.3×5	0.75	140	6.3×5	0.75	140
47	5×5	2.40	100	5×5	2.40	100	6.3×5	0.75	140	6.3×5	0.75	140			
68	6.3×5	0.75	140	6.3×5	0.75	140	6.3×5	0.75	140						
100	6.3×5	0.75	140	6.3×5	0.75	140									

## ● FREQUENCY COEFFICIENT OF PERMISSIBLE RIPPLE CURRENT

µF	Frequency	120Hz	1kHz	10kHz	50kHz	100kHz≤
~ 33		0.35	0.55	0.75	0.87	1.00
47 ~		0.40	0.60	0.80	0.90	1.00

# MINIATURE ALUMINUM ELECTROLYTIC CAPACITORS



## ZS High Ripple Current, Height 7mmL Series

**M** Miniaturized **S** Solvent Proof **IZI** Low Impedance

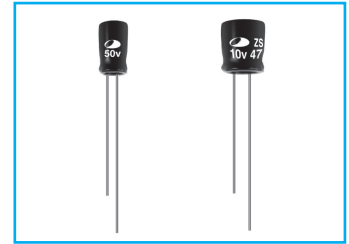

- Super miniature series with 7mmL height
- High ripple current compared with RK series
- Load life of 2000 hours at 105°C
- Complied to the RoHS directive

Item	Characteristics	
Operating temperature range	-40 ~ +105°C	
Leakage current	I = 0.01CV or 3μA whichever is greater (after 2 minutes) I = 0.03CV or 4μA whichever is greater (after 1 minute)	
Capacitance tolerance	±20% at 120Hz, 20°C	
Dissipation factor max. (at 120Hz, 20°C)	WV      6.3      10      16      25      35      50	
	tanδ    0.22    0.19    0.16    0.14    0.12    0.10	
Low temperature characteristics (Impedance ratio at 120Hz)	WV      6.3      10      16      25      35      50	
	Z-25°C / Z+20°C    2      2      2      2      2      2	
	Z-40°C / Z+20°C    6      4      3      3      3      3	
Load life	After an application of DC bias voltage plus the rated AC ripple current for 2000 hours at 105°C. The measurement shall meet the following limits. The DC voltage plus the peak AC voltage combined must not exceed the rated voltage.	
	Leakage current	Less than specified value
	Capacitance change	Within ±25% of the initial value
	tanδ	Less than 200% of the specified value
Shelf life (at 105°C)	After 1000 hours no load test, leakage current, capacitance and tanδ are same as load life value. The measurement shall be performed at 20°C by the KS C IEC 60384 - 4	

### DRAWING

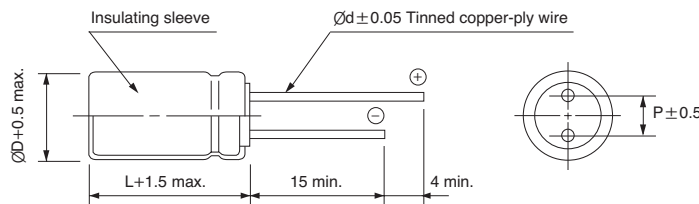

Unit : mm

ØD	5	6.3	8
P	2.0	2.5	3.5
Ød	0.5	0.5	0.5

### DIMENSIONS & MAXIMUM PERMISSIBLE RIPPLE CURRENT

WV Item μF	6.3		10		16		25		35		50	
	ØD × L (mm)	Imp.(Ω) max. 20°C 100kHz	Ripple current (mA rms) 105°C 100kHz	ØD × L (mm)	Imp.(Ω) max. 20°C 100kHz	Ripple current (mA rms) 105°C 100kHz	ØD × L (mm)	Imp.(Ω) max. 20°C 100kHz	Ripple current (mA rms) 105°C 100kHz	ØD × L (mm)	Imp.(Ω) max. 20°C 100kHz	Ripple current (mA rms) 105°C 100kHz
2.2												
4.7												
10												
22												
33	5×7	1.40	165	5×7	1.40	165	5×7	1.40	165	5×7	1.40	165
47	5×7	1.40	165	5×7	1.40	165	5×7	1.40	165	6.3×7	0.70	235
68	6.3×7	0.70	235	6.3×7	0.70	235	6.3×7	0.70	235	6.3×7	0.70	235
100	6.3×7	0.70	235	6.3×7	0.70	235	6.3×7	0.70	235	8×7	0.34	350
150	6.3×7	0.70	235	6.3×7	0.70	235	8×7	0.34	350			
220	8×7	0.34	350	8×7	0.34	350						
330	8×7	0.34	350									

### FREQUENCY COEFFICIENT OF PERMISSIBLE RIPPLE CURRENT

μF	Frequency	120Hz	1kHz	10kHz	50kHz	100kHz ≤
~ 33		0.35	0.55	0.75	0.87	1.00
47 ~ 150		0.40	0.60	0.80	0.90	1.00
220 ~		0.50	0.65	0.85	0.92	1.00

MINIATURE TYPES

# MINIATURE ALUMINUM ELECTROLYTIC CAPACITORS

**ZL** High Ripple Current, Height 7mmL Series

**M** Miniaturized **S** Solvent Proof **IZL** Low Impedance

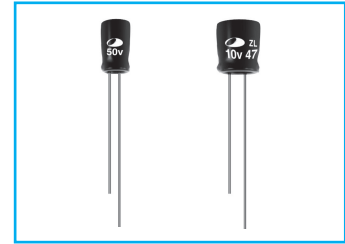

- Super miniature series with 7mmL height
- Load life of 3000 hours at 105°C
- Complied to the RoHS directive

**ZS** → **ZL**  
High Ripple

Item	Characteristics						
Operating temperature range	-40 ~ +105°C						
Leakage current	I = 0.01CV or 3μA whichever is greater (after 2 minutes) I = 0.03CV or 4μA whichever is greater (after 1 minute)						
Capacitance tolerance	±20% at 120Hz, 20°C						
Dissipation factor max. (at 120Hz, 20°C)	WV	6.3	10	16	25	35	50
	tanδ	0.22	0.19	0.16	0.14	0.12	0.10
Low temperature characteristics (Impedance ratio at 120Hz)	WV	6.3	10	16	25	35	50
	Z-25°C / Z+20°C	2	2	2	2	2	2
	Z-40°C / Z+20°C	6	4	3	3	3	3
Load life	After an application of DC bias voltage plus the rated AC ripple current for 3000 hours at 105°C. The measurement shall meet the following limits. The DC voltage plus the peak AC voltage combined must not exceed the rated voltage.						
	Leakage current	Less than specified value					
	Capacitance change	Within ±25% of the initial value					
	tanδ	Less than 200% of the specified value					
Shelf life (at 105°C)	After 1000 hours no load test, leakage current, capacitance and tanδ are same as load life value. The measurement shall be performed at 20°C by the KS C IEC 60384 - 4						

## ● DRAWING

Unit : mm

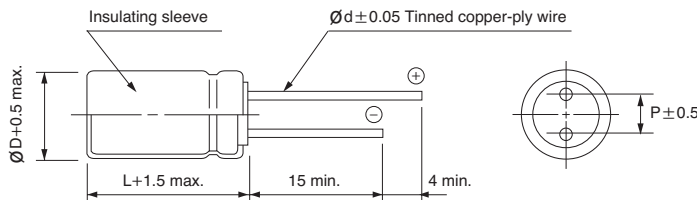

ØD	5	6.3	8
P	2.0	2.5	3.5
Ød	0.5	0.5	0.5

## ● DIMENSIONS & MAXIMUM PERMISSIBLE RIPPLE CURRENT

WV	6.3		10		16		25		35		50							
	Item	Imp.(Ω) max. 20°C	Ripple current (mA rms) 105°C	Imp.(Ω) max. 20°C	Ripple current (mA rms) 105°C	Imp.(Ω) max. 20°C	Ripple current (mA rms) 105°C	Imp.(Ω) max. 20°C	Ripple current (mA rms) 105°C	Imp.(Ω) max. 20°C	Ripple current (mA rms) 105°C	Imp.(Ω) max. 20°C	Ripple current (mA rms) 105°C					
μF	ØD×L (mm)	100kHz	100kHz	100kHz	100kHz	100kHz	100kHz	100kHz	100kHz	100kHz	100kHz	100kHz	100kHz					
2.2												5×7	1.00	165				
10												6.3×7	0.45	235				
22										5×7	0.84	165	6.3×7	0.45	235			
33	5×7	0.84	165	5×7	0.84	165	5×7	0.84	165	5×7	0.84	165	6.3×7	0.42	235	8×7	0.30	350
47	5×7	0.84	165	5×7	0.84	165	5×7	0.84	165	6.3×7	0.42	235	8×7	0.20	350	8×7	0.25	350
68	6.3×7	0.42	235	6.3×7	0.42	235	6.3×7	0.42	235	6.3×7	0.42	235	8×7	0.20	350			
100	6.3×7	0.42	235	6.3×7	0.42	235	6.3×7	0.42	235	8×7	0.20	350						
150	6.3×7	0.42	235	6.3×7	0.42	235	8×7	0.20	350									
220	8×7	0.20	350	8×7	0.20	350												
330	8×7	0.20	350															

## ● FREQUENCY COEFFICIENT OF PERMISSIBLE RIPPLE CURRENT (See page 99)

# MINIATURE ALUMINUM ELECTROLYTIC CAPACITORS



## ZT Long Life, Height 7mmL Series

- Super miniature series with 7mmL height
- Load life of 5000 hours at 105°C
- Complied to the RoHS directive, Halogen-Free

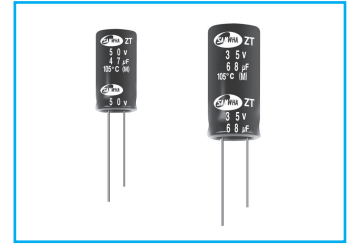

Item	Characteristics						
Operating temperature range	-40 ~ +105°C						
Leakage current max.	I = 0.01CV or 3μA (after 2 minutes)						
Capacitance tolerance	±20% at 120Hz, 20°C						
Dissipation factor max. (at 120Hz, 20°C)	WV	6.3	10	16	25	35	50
	tanδ	0.40	0.35	0.30	0.25	0.20	0.20
Low temperature characteristics (Impedance ratio at 120Hz)	WV	6.3	10	16	25	35	50
	Z-25°C/Z+20°C	6	4	4	3	3	3
	Z-40°C/Z+20°C	12	10	8	6	6	6
Load life (after application of the rated voltage for 5000 hours at 105°C)	Leakage current	Less than specified value					
	Capacitance change	Within ±30% of initial value					
	tanδ	Less than 300% of specified value					
Shelf life (at 105°C)	After 1000 hours no load test, leakage current, capacitance and tanδ are same as load life value. The measurement shall be performed at 20°C by the KS C IEC 60384 - 4						

### DRAWING

Unit : mm

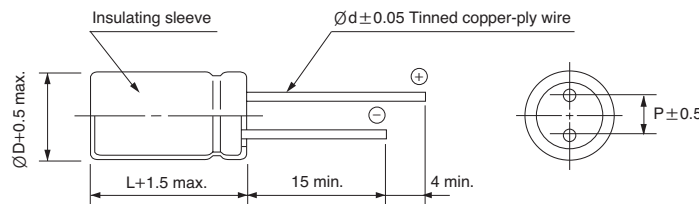

ØD	5	6.3	8
P	2.0	2.5	3.5
Ød	0.5	0.5	0.5

### DIMENSIONS & MAXIMUM PERMISSIBLE RIPPLE CURRENT

μF \ WV	6.3		10		16		25		35		50	
2.2											5×7	165
10											6.3×7	235
22									5×7	165	6.3×7	260
33	5×7	165	5×7	165	5×7	165	5×7	165	6.3×7	235	8×7	350
47	5×7	165	5×7	165	5×7	165	6.3×7	235	8×7	350	8×7	450
68	6.3×7	235	6.3×7	235	6.3×7	235	6.3×7	235	8×7	350		
100	6.3×7	235	6.3×7	235	6.3×7	235	8×7	350				
150	6.3×7	235	6.3×7	235	8×7	350						
220	8×7	350	8×7	350								
330	8×7	350										

Ripple current (mA rms) at 105°C, 100kHz  
 Case size ØD×L (mm)

### FREQUENCY COEFFICIENT OF PERMISSIBLE RIPPLE CURRENT

μF \ Frequency	120Hz	1kHz	10kHz	50kHz	100kHz ≤
~ 33	0.25	0.50	0.75	0.90	1.00
47 ~	0.30	0.55	0.80	0.90	1.00

# MINIATURE ALUMINUM ELECTROLYTIC CAPACITORS

**WL** Low Impedance Series

 Long Life  
 Solvent Proof  
 Low Impedance  
 WV ≤ 100V

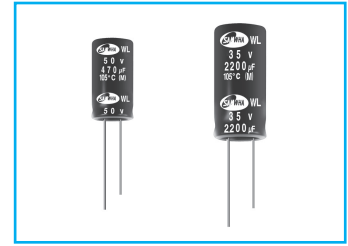

 ⇒ **WF**  
 Long life

- Wide voltage compared with RZ series
- Operating temperature range of -40 ~ +105°C
- Low impedance at high frequency
- High reliability withstanding 5000 hours load life at 105°C
- For E-meter
- Complied to the RoHS directive

Item	Characteristics										
Operating temperature range	WV	6.3 ~ 450									
	Temperature range	-40 ~ +105°C									
Leakage current max.	WV ≤ 100	WV > 100									
	I = 0.01CV or 3µA whichever is greater (after 2 min.) I = 0.03CV or 4µA whichever is greater (after 1 min.)										
Capacitance tolerance	±20% at 120Hz, 20°C										
Dissipation factor max. (at 120Hz, 20°C)	Capacitance > 1000µF : tanδ increases by 0.02 for each 1000µF from below value.										
	WV	6.3	10	16	25	35	50	63	100	160~250	350~500
	tanδ	0.22	0.19	0.16	0.14	0.12	0.10	0.09	0.08	0.15	0.20
Low temperature characteristics (Impedance ratio at 120Hz)	WV	6.3	10	16	25 ~ 100	160 ~ 250	350 ~ 450	500			
	Z-25°C/Z+20°C	4	3	2	2	3	6	8			
	Z-40°C/Z+20°C	8	6	4	3	4	10	-			
Load life	After an application of DC bias voltage plus the rated AC ripple current for 5000 hours at 105°C. The measurement shall meet the following limits. The DC voltage plus the peak AC voltage combined must not exceed the rated voltage.										
	Leakage current	Less than specified value									
	Capacitance change	Within ±25% of initial value									
	tanδ	Less than 200% of specified value									
	Life time	ØD = 5, 6.3			ØD = 8			ØD ≥ 10			
WV ≤ 100	2000 hours			3000 hours			5000 hours				
WV > 100	2000 hours										
Shelf life (at 105°C)	After 1000 hours no load test, leakage current, capacitance and tanδ are same as load life value. The measurement shall be performed at 20°C by the KS C IEC 60384 - 4										

## ● DRAWING

Unit : mm

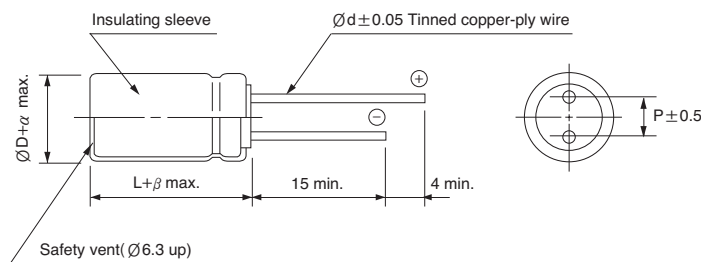

ØD	5	6.3	8	10	12.5	16	18	20	22
P	2.0	2.5	3.5	5.0	5.0	7.5	7.5	10.0	10.0
Ød	0.5	0.5	0.6	0.6	0.6	0.8	0.8	0.8	1.0
α	0.5							1.0	
β	1.5		2.0			3.0			

## ● FREQUENCY COEFFICIENT OF PERMISSIBLE RIPPLE CURRENT

µF	Frequency	120Hz	1kHz	10kHz	50kHz	100kHz ≤
~ 33		0.40	0.65	0.82	0.91	1.00
47 ~ 220		0.50	0.70	0.84	0.92	1.00
330 ~ 680		0.55	0.75	0.86	0.93	1.00
820 ~ 1500		0.60	0.80	0.88	0.94	1.00
2200 ~		0.70	0.85	0.90	0.95	1.00

## WL series

### ● DIMENSIONS & MAXIMUM PERMISSIBLE RIPPLE CURRENT

WV Item μF	6.3			10			16			25		
	∅D × L (mm)	Impedance (Ω)max. 20°C 100kHz	Ripple current (mA rms) 105°C 100kHz	∅D × L (mm)	Impedance (Ω)max. 20°C 100kHz	Ripple current (mA rms) 105°C 100kHz	∅D × L (mm)	Impedance (Ω)max. 20°C 100kHz	Ripple current (mA rms) 105°C 100kHz	∅D × L (mm)	Impedance (Ω)max. 20°C 100kHz	Ripple current (mA rms) 105°C 100kHz
10							5 × 11	0.90	180	5 × 11	0.90	180
22	5 × 11	0.70	180	5 × 11	0.70	180	5 × 11	0.70	180	5 × 11	0.70	180
33	5 × 11	0.70	180	5 × 11	0.70	180	5 × 11	0.70	180	5 × 11	0.70	180
47	5 × 11	0.65	180	5 × 11	0.65	180	5 × 11	0.65	180	5 × 11	0.65	180
100	5 × 11	0.65	180	5 × 11	0.65	180	6.3 × 11	0.30	280	6.3 × 11	0.30	280
150	6.3 × 11	0.30	280	6.3 × 11	0.30	280	6.3 × 11	0.30	280	8 × 11.5	0.20	450
220	6.3 × 11	0.30	280	6.3 × 11	0.30	280	8 × 11.5	0.14	450	8 × 11.5	0.20	450
330	6.3 × 11	0.30	280	8 × 11.5	0.14	450	8 × 11.5	0.14	450	10 × 12.5	0.10	660
470	8 × 11.5	0.14	450	8 × 11.5	0.14	450	10 × 12.5	0.10	660	10 × 16	0.080	850
680	10 × 12.5	0.10	660	10 × 12.5	0.10	660	10 × 16	0.080	850	10 × 20	0.054	1100
1000	10 × 12.5	0.10	660	10 × 16	0.080	850	10 × 20	0.054	1100	12.5 × 20	0.050	1400
1500	10 × 20	0.054	1100	10 × 20	0.054	1100	12.5 × 20	0.050	1400	16 × 20	0.030	2100
2200	12.5 × 20	0.050	1400	12.5 × 20	0.050	1400	12.5 × 25	0.038	1700	16 × 25	0.030	2100
3300	12.5 × 20	0.050	1400	12.5 × 25	0.038	1700	16 × 25	0.030	2100	16 × 31.5	0.025	2600
4700	16 × 25	0.030	2100	16 × 25	0.030	2100	16 × 31.5	0.025	2600	18 × 35.5	0.022	3000
6800	16 × 25	0.030	2100	16 × 31.5	0.025	2600	18 × 35.5	0.022	3000			
10000	16 × 31.5	0.025	2600	18 × 35.5	0.022	3000						
15000	18 × 35.5	0.022	3000									

WV Item μF	35			50			63			100		
	∅D × L (mm)	Impedance (Ω)max. 20°C 100kHz	Ripple current (mA rms) 105°C 100kHz	∅D × L (mm)	Impedance (Ω)max. 20°C 100kHz	Ripple current (mA rms) 105°C 100kHz	∅D × L (mm)	Impedance (Ω)max. 20°C 100kHz	Ripple current (mA rms) 105°C 100kHz	∅D × L (mm)	Impedance (Ω)max. 20°C 100kHz	Ripple current (mA rms) 105°C 100kHz
1.0				5 × 11	3.0	40						
2.2				5 × 11	3.0	55				5 × 11	2.5	52
3.3				5 × 11	2.6	65	5 × 11	2.0	64	5 × 11	2.5	64
4.7	5 × 11	0.90	180	5 × 11	2.3	90	5 × 11	2.0	76	5 × 11	2.5	76
10	5 × 11	0.90	180	5 × 11	1.4	120	5 × 11	2.0	111	6.3 × 11	1.0	128
22	5 × 11	0.70	180	5 × 11	1.2	150	6.3 × 11	0.60	190	8 × 11.5	0.60	224
33	5 × 11	0.65	180	6.3 × 11	0.60	200	6.3 × 11	0.60	233	10 × 12.5	0.40	319
47	6.3 × 11	0.30	280	6.3 × 11	0.43	250	8 × 11.5	0.50	328	10 × 16	0.30	417
100	8 × 11.5	0.20	450	8 × 11.5	0.24	340	10 × 16	0.12	456	12.5 × 20	0.15	570
150	8 × 11.5	0.14	450	10 × 12.5	0.17	490	10 × 20	0.10	610	12.5 × 25	0.12	762
220	10 × 12.5	0.10	660	10 × 16	0.12	650	12.5 × 20	0.090	809	16 × 25	0.070	1250
330	10 × 16	0.080	850	10 × 20	0.10	810	12.5 × 20	0.085	1036	16 × 31.5	0.050	1404
470	10 × 20	0.054	1100	12.5 × 20	0.085	1100	16 × 20	0.050	1411	18 × 40	0.030	1980
680	12.5 × 20	0.050	1400	12.5 × 25	0.065	1200	16 × 25	0.043	1843	18 × 40	0.030	2050
820	12.5 × 25	0.045	1500	16 × 25	0.055	1300	18 × 25	0.035	1900	18 × 40	0.030	2215
1000	12.5 × 25	0.038	1700	16 × 25	0.043	1600	16 × 35.5	0.025	1967			
1500	16 × 25	0.030	2100	16 × 31.5	0.038	2000						
2200	16 × 31.5	0.025	2600	18 × 35.5	0.034	2300						
3300	18 × 35.5	0.022	3000									

# MINIATURE ALUMINUM ELECTROLYTIC CAPACITORS

**WL** series

● DIMENSIONS & MAXIMUM PERMISSIBLE RIPPLE CURRENT

WV Item $\mu\text{F}$	160		200		250		350	
	$\varnothing\text{D}\times\text{L}$ (mm)	Ripple current (mA rms) 105°C 100kHz	$\varnothing\text{D}\times\text{L}$ (mm)	Ripple current (mA rms) 105°C 100kHz	$\varnothing\text{D}\times\text{L}$ (mm)	Ripple current (mA rms) 105°C 100kHz	$\varnothing\text{D}\times\text{L}$ (mm)	Ripple current (mA rms) 105°C 100kHz
1	6.3×11	45						
10	10×12.5	230			10×16	300	10×16	180
22	10×16	440	10×20	440	10×20	480	12.5×20	270
33	10×16	560	12.5×20	590	12.5×20	630	16×20	600
47	10×20	725	12.5×20	780	12.5×25	630	16×25	700
68	12.5×25	950	12.5×25	950	16×25	1000	16×31.5	1100
82					16×25	1100	16×35.5	1130
100	16×25	1280	16×25	1280	16×31.5	1400	18×31.5	1170
120							18×35.5	1200
150	16×25	1300	16×25	1500	18×25 18×31.5	1450	18×40	1250
220	16×31.5	1500	18×31.5	1700	18×35.5 18×40	1485		
330	18×31.5	1700	18×35.5	1900				

WV Item $\mu\text{F}$	400		420		450		500	
	$\varnothing\text{D}\times\text{L}$ (mm)	Ripple current (mA rms) 105°C 100kHz	$\varnothing\text{D}\times\text{L}$ (mm)	Ripple current (mA rms) 105°C 100kHz	$\varnothing\text{D}\times\text{L}$ (mm)	Ripple current (mA rms) 105°C 100kHz	$\varnothing\text{D}\times\text{L}$ (mm)	Ripple current (mA rms) 105°C 100kHz
3.3					10×12.5	150		
4.7					10×16	200		
10	10×16	176			10×16	230	12.5×20	240
22	12.5×25	300			12.5×25	525	12.5×30	420
33	16×20	600			16×25	600	16×31.5	560
47	16×25	700	16×25	630	16×25 16×31.5 18×25	660 720 720	16×35.5 18×31.5 18×35.5	650 620 700
56			16×31.5 18×25	740	16×31.5 18×25	800 800	16×40	740
68	16×31.5	1100	16×35.5 18×25	810	16×35.5 18×31.5	900 900	16×45 18×40	820 900
82	16×35.5	1150	16×40 18×31.5	960 900	16×40 18×31.5 18×35.5	1115 1115 1200	16×50 18×40	1000 1000
100	18×35.5	1200	16×40 18×35.5	1100	16×40 18×35.5	1300	16×50 18×45 20×41	1250 1250 1250
120	18×40	1270	16×50 18×40	1250 1200	16×50 18×40	1500 1500	22×45	1370
150	20×41	1380			20×41	1600		

## MD High Ripple Current, Ultra Low Impedance Series

**IZI** Low Impedance **S** Solvent Proof

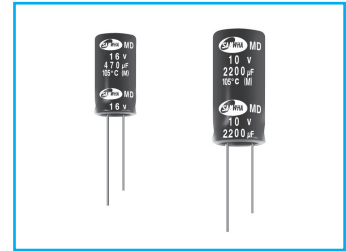

- High ripple current compared with MZ series
- Enabled ripple current with extremely low impedance at high frequency range
- High reliability withstanding 2000 hours load life at 105°C
- Complied to the RoHS directive

MZ → MD  
High Ripple

Item	Characteristics			
Operating temperature range	-40 ~ +105°C			
Leakage current max.	I = 0.01CV or 3µA whichever is greater (after 2 minutes) I = 0.03CV or 4µA whichever is greater (after 1 minute)			
Capacitance tolerance	±20% at 120Hz, 20°C			
Dissipation factor max. (at 120Hz, 20°C)	Capacitance > 1000µF : tanδ increases by 0.02 for each 1000µF from below value.			
	WV	6.3	10	16
	tanδ	0.22	0.19	0.16
Low temperature characteristics (Impedance ratio at 120Hz)	WV	6.3	10	16
	Z-40°C / Z+20°C	3	3	3
Load life	After an application of DC bias voltage plus the rated AC ripple current for 2000 hours at 105°C. The measurement shall meet the following limits. The DC voltage plus the peak AC voltage combined must not exceed the rated voltage.			
	Leakage current	Less than specified value		
	Capacitance change	Within ±25% of initial value		
	tanδ	Less than 200% of specified value		
Shelf life (at 105°C)	After 1000 hours no load test, leakage current, capacitance and tanδ are same as load life value. The measurement shall be performed at 20°C by the KS C IEC 60384 - 4			

● DRAWING (See page 89)

### ● DIMENSIONS & MAXIMUM PERMISSIBLE RIPPLE CURRENT

WV Item µF	6.3			10			16		
	ØD×L (mm)	Impedance (Ω)max. 20°C 100kHz	Ripple current (mA rms) 105°C 100kHz	ØD×L (mm)	Impedance (Ω)max. 20°C 100kHz	Ripple current (mA rms) 105°C 100kHz	ØD×L (mm)	Impedance (Ω)max. 20°C 100kHz	Ripple current (mA rms) 105°C 100kHz
470							8 × 11.5	0.021	1340
680				8 × 11.5	0.021	1340	8 × 15	0.020	1850
							10 × 12.5	0.020	1960
820	8 × 11.5	0.021	1340						
1000				8 × 15	0.020	1850	8 × 20	0.016	2350
				10 × 12.5	0.016	1960	10 × 16	0.016	2460
1500	10 × 12.5	0.016	1960	8 × 20	0.013	2350	10 × 20	0.014	2805
				10 × 16	0.013	2460			
1800	10 × 16	0.013	2460	10 × 20	0.011	2805	12.5 × 20	0.013	3230
2200	10 × 20	0.011	2805	12.5 × 20	0.009	3230			
3300	12.5 × 20	0.009	3230						

### ● FREQUENCY COEFFICIENT OF PERMISSIBLE RIPPLE CURRENT

µF	Frequency	120Hz	1kHz	10kHz	50kHz	100kHz ≤
~ 820		0.55	0.77	0.94	0.97	1.00
1000 ~ 1800		0.60	0.80	0.96	0.98	1.00
2200 ~		0.70	0.85	0.98	0.99	1.00



# MINIATURE ALUMINUM ELECTROLYTIC CAPACITORS

**RZ** Low Impedance Series

 Long Life   
  Solvent Proof   
  Low Impedance

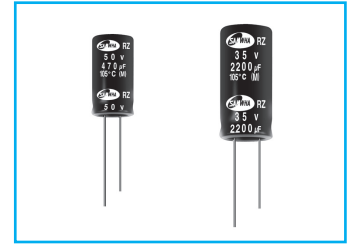

- Low impedance at high frequency
- High reliability withstanding 5000 hours load life at 105°C (2000/3000 hours for smaller case sizes as specified below)
- Ideally suited for use in switching power supplies
- Complied to the RoHS directive

  $\Rightarrow$   Long life

Item	Characteristics															
<b>Operating temperature range</b>	-55 ~ +105°C															
<b>Leakage current max.</b>	I = 0.01CV or 3µA whichever is greater (after 2 minutes) I = 0.03CV or 4µA whichever is greater (after 1 minute)															
<b>Capacitance tolerance</b>	±20% at 120Hz, 20°C															
<b>Dissipation factor max. (at 120Hz, 20°C)</b>	Capacitance > 1000µF : tanδ increases by 0.02 for each 1000µF from below value															
	<table border="1"> <tr> <td>WV</td> <td>6.3</td> <td>10</td> <td>16</td> <td>25</td> <td>35</td> <td>50</td> <td>63</td> </tr> <tr> <td>tanδ</td> <td>0.22</td> <td>0.19</td> <td>0.16</td> <td>0.14</td> <td>0.12</td> <td>0.10</td> <td>0.08</td> </tr> </table>	WV	6.3	10	16	25	35	50	63	tanδ	0.22	0.19	0.16	0.14	0.12	0.10
WV	6.3	10	16	25	35	50	63									
tanδ	0.22	0.19	0.16	0.14	0.12	0.10	0.08									
<b>Low temperature characteristics (Impedance ratio at 120Hz)</b>	<table border="1"> <tr> <td>WV</td> <td>6.3, 10</td> <td>16 ~ 35</td> <td>50, 63</td> </tr> <tr> <td>Z-55°C/Z+20°C</td> <td>4</td> <td>3</td> <td>2</td> </tr> </table>	WV	6.3, 10	16 ~ 35	50, 63	Z-55°C/Z+20°C	4	3	2							
	WV	6.3, 10	16 ~ 35	50, 63												
Z-55°C/Z+20°C	4	3	2													
<b>Load life</b>	After an application of DC bias voltage plus the rated AC ripple current for 5000 hours at 105°C. The measurement shall meet the following limits. The DC voltage plus the peak AC voltage combined must not exceed the rated voltage.															
	<table border="1"> <tr> <td>Leakage current</td> <td>Less than specified value</td> </tr> <tr> <td>Capacitance change</td> <td>Within ±20% of initial value</td> </tr> <tr> <td>tanδ</td> <td>Less than 200% of specified value</td> </tr> </table>	Leakage current	Less than specified value	Capacitance change	Within ±20% of initial value	tanδ	Less than 200% of specified value									
	Leakage current	Less than specified value														
	Capacitance change	Within ±20% of initial value														
tanδ	Less than 200% of specified value															
<table border="1"> <tr> <td>∅D</td> <td>∅D ≤ 6.3</td> <td>∅D = 8</td> <td>∅D ≥ 10</td> </tr> <tr> <td>Life time</td> <td>2000 hours</td> <td>3000 hours</td> <td>5000 hours</td> </tr> </table>	∅D	∅D ≤ 6.3	∅D = 8	∅D ≥ 10	Life time	2000 hours	3000 hours	5000 hours								
∅D	∅D ≤ 6.3	∅D = 8	∅D ≥ 10													
Life time	2000 hours	3000 hours	5000 hours													
After 1000 hours no load test, leakage current, capacitance and tanδ are same as load life value. The measurement shall be performed at 20°C by the KS C IEC 60384 - 4																
<b>Shelf life (at 105°C)</b>	<table border="1"> <tr> <td>Leakage current</td> <td>Less than specified value</td> </tr> <tr> <td>Capacitance change</td> <td>Within ±20% of initial value</td> </tr> <tr> <td>tanδ</td> <td>Less than 150% of specified value</td> </tr> </table>	Leakage current	Less than specified value	Capacitance change	Within ±20% of initial value	tanδ	Less than 150% of specified value									
	Leakage current	Less than specified value														
	Capacitance change	Within ±20% of initial value														
tanδ	Less than 150% of specified value															

## ● DRAWING

Unit : mm

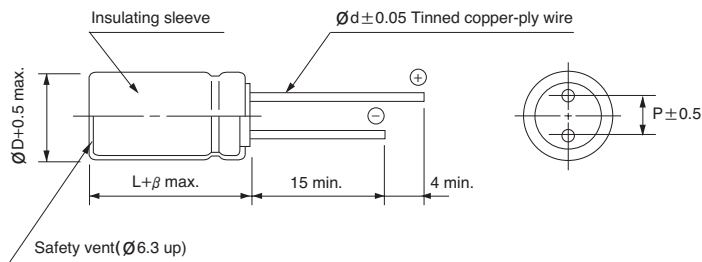

∅D	5	6.3	8	10	12.5	16	18
P	2.0	2.5	3.5	5.0	5.0	7.5	7.5
∅d	0.5	0.5	0.6	0.6	0.6	0.8	0.8
β	1.5			2.0			

## ● FREQUENCY COEFFICIENT OF PERMISSIBLE RIPPLE CURRENT

µF \ Frequency	120Hz	1kHz	10kHz	50kHz	100kHz ≤
~ 33	0.40	0.65	0.82	0.91	1.00
47 ~ 220	0.50	0.70	0.84	0.92	1.00
330 ~ 680	0.55	0.75	0.86	0.93	1.00
1000 ~ 1500	0.60	0.80	0.88	0.94	1.00
2200 ~	0.70	0.85	0.90	0.95	1.00

## RZ series

### ● DIMENSIONS & MAXIMUM PERMISSIBLE RIPPLE CURRENT

WV Item $\mu$ F	6.3			10			16			25		
	$\varnothing$ D×L (mm)	Impedance ( $\Omega$ )max. 20°C 100kHz	Ripple current (mA rms) 105°C 100kHz	$\varnothing$ D×L (mm)	Impedance ( $\Omega$ )max. 20°C 100kHz	Ripple current (mA rms) 105°C 100kHz	$\varnothing$ D×L (mm)	Impedance ( $\Omega$ )max. 20°C 100kHz	Ripple current (mA rms) 105°C 100kHz	$\varnothing$ D×L (mm)	Impedance ( $\Omega$ )max. 20°C 100kHz	Ripple current (mA rms) 105°C 100kHz
33										5×11	0.80	155
47							5×11	0.80	155	6.3×11	0.55	210
68				5×11	0.80	155	6.3×11	0.50	220	6.3×11	0.36	260
100	5×11	0.85	150	6.3×11	0.55	210	6.3×11	0.35	265	8×11.5	0.24	383
150	6.3×11	0.49	225	6.3×11	0.35	265	8×11.5	0.23	388	8×11.5	0.16	460
220	6.3×11	0.30	285	8×11.5	0.24	387	8×11.5	0.16	460	10×12.5	0.13	600
330	8×11.5	0.20	292	8×11.5	0.16	460	10×12.5	0.12	625	10×16	0.095	750
470	10×12.5	0.14	575	10×12.5	0.13	600	10×16	0.09	770	10×20	0.065	1020
680	10×16	0.11	700	10×16	0.09	770	10×20	0.065	1020	12.5×20	0.046	1392
1000	10×20	0.075	950	10×20	0.060	1060	12.5×20	0.047	1411	12.5×25	0.036	1660
1500	12.5×20	0.055	1220	12.5×20	0.045	1417	12.5×25	0.036	1660	16×20	0.034	1770
2200	12.5×20	0.043	1438	12.5×25	0.034	1710	16×20	0.033	1800	16×25	0.028	2051
3300	12.5×25	0.034	1710	16×20	0.031	1850	16×25	0.027	2095	16×35.5	0.020	2680
4700	16×25	0.032	1935	16×31.5	0.023	2420	16×35.5	0.020	2680	18×40	0.018	2960
6800	16×31.5	0.024	2370	16×35.5	0.020	2680	18×35.5	0.018	2900			
10000	16×40	0.020	2750	18×40	0.017	3040						
15000	18×40	0.018	2960									

WV Item $\mu$ F	35			50			63		
	$\varnothing$ D×L (mm)	Impedance ( $\Omega$ )max. 20°C 100kHz	Ripple current (mA rms) 105°C 100kHz	$\varnothing$ D×L (mm)	Impedance ( $\Omega$ )max. 20°C 100kHz	Ripple current (mA rms) 105°C 100kHz	$\varnothing$ D×L (mm)	Impedance ( $\Omega$ )max. 20°C 100kHz	Ripple current (mA rms) 105°C 100kHz
1.0				5×11	4.00	36			
1.5				5×11	3.80	45			
2.2				5×11	3.50	54			
3.3				5×11	3.00	66			
4.7				5×11	2.20	81			
6.8				5×11	1.80	91			
10				5×11	1.80	115	5×11	1.80	135
15				5×11	1.60	145	6.3×11	1.00	185
22	5×11	0.75	160	6.3×11	1.40	195	6.3×11	1.00	215
33	6.3×11	0.49	225	6.3×11	1.20	240	8×11.5	0.80	320
47	6.3×11	0.34	270	8×11.5	0.80	344	8×11.5	0.80	365
68	8×11.5	0.24	384	8×11.5	0.65	410	10×12.5	0.23	495
100	8×11.5	0.16	460	10×16	0.40	581	10×20	0.16	750
150	10×12.5	0.12	625	10×20	0.30	820	12.5×20	0.12	950
220	10×16	0.09	770	12.5×20	0.20	1040	12.5×20	0.085	1140
330	10×20	0.060	1060	12.5×20	0.12	1281	12.5×25	0.060	1420
470	12.5×20	0.046	1401	12.5×25	0.085	1500	16×25	0.055	1700
680	12.5×25	0.036	1660	16×20	0.060	1630	16×31.5	0.032	2050
1000	16×20	0.034	1770	16×31.5	0.040	2120	18×35.5	0.029	2280
1500	16×31.5	0.028	2385	16×40	0.035	2410			
2200	16×35.5	0.020	2680	18×40	0.030	2560			
3300	18×40	0.017	3040						

# MINIATURE ALUMINUM ELECTROLYTIC CAPACITORS

**MK** High Ripple Current Series

**I Z I** Low Impedance **S** Solvent Proof

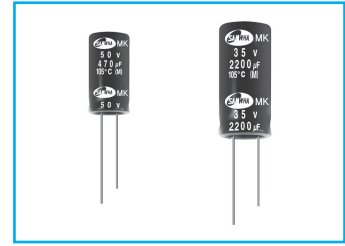

- Ripple current compared with RZ series
- Enabled high ripple current by a reduction of impedance at high frequency
- High reliability withstanding 5000 hours load life at 105°C (2000 ~ 3000 hours for smaller case sizes as specified below)
- Complied to the RoHS directive

RZ → **MK**  
Miniature High Ripple

Item	Characteristics																	
Operating temperature range	-40 ~ +105°C																	
Leakage current max.	I = 0.01CV or 3µA whichever is greater (after 2 minutes) I = 0.03CV or 4µA whichever is greater (after 1 minute)																	
Capacitance tolerance	±20% at 120Hz, 20°C																	
Dissipation factor max. (at 120Hz, 20°C)	Capacitance > 1000µF : tanδ increases by 0.02 for each 1000µF from below value.																	
	<table border="1"> <thead> <tr> <th>WV</th> <th>6.3</th> <th>10</th> <th>16</th> <th>25</th> <th>35</th> <th>50</th> <th>63</th> <th>100</th> </tr> </thead> <tbody> <tr> <td>tanδ</td> <td>0.22</td> <td>0.19</td> <td>0.16</td> <td>0.14</td> <td>0.12</td> <td>0.10</td> <td>0.08</td> <td>0.08</td> </tr> </tbody> </table>	WV	6.3	10	16	25	35	50	63	100	tanδ	0.22	0.19	0.16	0.14	0.12	0.10	0.08
WV	6.3	10	16	25	35	50	63	100										
tanδ	0.22	0.19	0.16	0.14	0.12	0.10	0.08	0.08										
Low temperature characteristics (Impedance ratio at 120Hz)	Z-40°C / Z+20°C																	
	Z-25°C / Z+20°C																	
Load life	After an application of DC bias voltage plus the rated AC ripple current for 5000 hours at 105°C. The measurement shall meet the following limits. The DC voltage plus the peak AC voltage combined must not exceed the rated voltage.																	
	Leakage current	Less than specified value																
	Capacitance change	Within ±25% of the initial value																
	tanδ	Less than 200% of the specified value																
	<table border="1"> <thead> <tr> <th>∅D</th> <th>∅D = 5, 6.3</th> <th>∅D = 8</th> <th>∅D ≥ 10</th> </tr> </thead> <tbody> <tr> <td>Life time</td> <td>2000 hours</td> <td>3000 hours</td> <td>5000 hours</td> </tr> </tbody> </table>	∅D	∅D = 5, 6.3	∅D = 8	∅D ≥ 10	Life time	2000 hours	3000 hours	5000 hours									
∅D	∅D = 5, 6.3	∅D = 8	∅D ≥ 10															
Life time	2000 hours	3000 hours	5000 hours															
Shelf life (at 105°C)	After 1000 hours no load test, leakage current, capacitance and tanδ are same as load life value. The measurement shall be performed at 20°C by the KS C IEC 60384 - 4																	

## ● DRAWING

Unit : mm

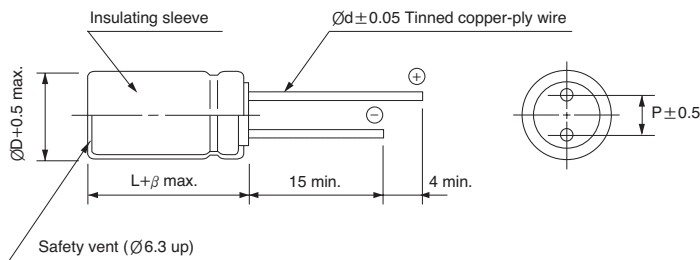

∅D	5	6.3	8	10	12.5	16	18
P	2.0	2.5	3.5	5.0	5.0	7.5	7.5
∅d	0.5	0.5	0.6	0.6	0.6	0.8	0.8
β	1.5			2.0			

## ● FREQUENCY COEFFICIENT OF PERMISSIBLE RIPPLE CURRENT

µF \ Frequency	120Hz	1kHz	10kHz	50kHz	100kHz ≤
~ 33	0.40	0.65	0.82	0.94	1.00
47 ~ 220	0.50	0.70	0.84	0.96	1.00
330 ~ 680	0.55	0.75	0.86	0.96	1.00
820 ~ 1800	0.60	0.80	0.88	0.97	1.00
2200 ~	0.70	0.85	0.90	0.97	1.00

## MK series

### ● DIMENSIONS & MAXIMUM PERMISSIBLE RIPPLE CURRENT

WV Item μF	6.3			10			16			25		
	ØD×L (mm)	Impedance (Ω)max. 20°C 100kHz	Ripple current (mA rms) 105°C 100kHz	ØD×L (mm)	Impedance (Ω)max. 20°C 100kHz	Ripple current (mA rms) 105°C 100kHz	ØD×L (mm)	Impedance (Ω)max. 20°C 100kHz	Ripple current (mA rms) 105°C 100kHz	ØD×L (mm)	Impedance (Ω)max. 20°C 100kHz	Ripple current (mA rms) 105°C 100kHz
10							5 × 11	0.525	250	5 × 11	0.85	250
22	5 × 11	0.525	250	5 × 11	0.525	250	5 × 11	0.525	270	5 × 11	0.525	270
33	5 × 11	0.525	270	5 × 11	0.525	270	5 × 11	0.525	290	5 × 11	0.525	290
47	5 × 11	0.450	290	5 × 11	0.450	290	5 × 11	0.450	310	5 × 11	0.500	310
100	5 × 11	0.450	310	5 × 11	0.450	310	5 × 11	0.450	310	6.3 × 11	0.225	460
							6.3 × 11	0.300	405			
150	6.3 × 11	0.300	405	6.3 × 11	0.300	405	6.3 × 11	0.225	460	8 × 11.5	0.160	760
220	6.3 × 11	0.225	460	6.3 × 11	0.225	460	8 × 11.5	0.108	760	8 × 11.5	0.160	950
330	6.3 × 11	0.225	505	8 × 11.5	0.150	760	8 × 11.5	0.108	950	10 × 12.5	0.088	1280
390	8 × 11.5	0.108	550	8 × 11.5	0.150	760	8 × 15	0.098	1000	8 × 15	0.098	1430
							10 × 12.5	0.098	1000	10 × 12.5	0.098	1430
470	8 × 11.5	0.108	950	8 × 11.5	0.150	950	8 × 11.5	0.108	950	10 × 12.5	0.098	1430
							8 × 15	0.098	1100	10 × 16	0.065	1785
							10 × 12.5	0.088	1280	10 × 20	0.060	1785
560	8 × 15	0.098	1000	8 × 15	0.098	1100	8 × 20	0.088	1280	8 × 20	0.088	1900
	10 × 12.5	0.098	1050	10 × 12.5	0.098	1100	10 × 16	0.088	1280	10 × 16	0.088	1900
680	10 × 12.5	0.088	1280	8 × 15	0.098	1280	10 × 16	0.065	1785	10 × 16	0.065	1900
10 × 12.5				0.088	10 × 20					0.050	2270	
820	10 × 16	0.075	1300	10 × 12.5	0.088	1400	10 × 16	0.065	1785	10 × 20	0.050	2300
1000	10 × 16	0.065	1785	8 × 20	0.088	1600	8 × 20	0.088	2000	10 × 20	0.050	2400
				10 × 12.5			0.065	10 × 16				
				10 × 16	0.065	1785	10 × 20	0.050	2270			
1200				10 × 16	0.065	2200				12.5 × 20	0.043	3100
1500	10 × 20	0.050	2270	10 × 20	0.050	2270	12.5 × 20	0.043	2450	12.5 × 25	0.029	3470
										16 × 20	0.029	3600
1800	10 × 20	0.050	2300	12.5 × 20	0.043	2350	12.5 × 25	0.029	2950	12.5 × 25	0.029	3650
2200	12.5 × 20	0.043	2950	10 × 20	0.05	2650						
				12.5 × 20	0.043	2950	12.5 × 25	0.029	3460	12.5 × 25	0.029	3700
3300	12.5 × 20	0.040	3000	12.5 × 25	0.029	3140	16 × 25	0.024	3500	16 × 31.5	0.024	3900
				16 × 20								
4700	16 × 25	0.024	3114	16 × 25	0.024	3200	16 × 31.5	0.024	3600	18 × 35.5	0.022	3950
6800	16 × 25	0.024	3114	16 × 31.5	0.024	3312	18 × 35.5	0.022	3700			
10000	16 × 31.5	0.024	3312	18 × 35.5	0.022	3420						
15000	18 × 35.5	0.022	3420									

# MINIATURE ALUMINUM ELECTROLYTIC CAPACITORS

**MK** series

● DIMENSIONS & MAXIMUM PERMISSIBLE RIPPLE CURRENT

WV Item μF	35			50			63			100		
	ØD×L (mm)	Impedance (Ω)max. 20°C 100kHz	Ripple current (mA rms) 105°C 100kHz	ØD×L (mm)	Impedance (Ω)max. 20°C 100kHz	Ripple current (mA rms) 105°C 100kHz	ØD×L (mm)	Impedance (Ω)max. 20°C 100kHz	Ripple current (mA rms) 105°C 100kHz	ØD×L (mm)	Impedance (Ω)max. 20°C 100kHz	Ripple current (mA rms) 105°C 100kHz
1.0				5×11	3.00	250						
2.2				5×11	3.00	250				5×11	3.000	125
3.3				5×11	1.50	250	5×11	2.000	165	5×11	2.000	125
4.7	5×11	0.525	250	5×11	1.50	270	5×11	2.000	165	5×11	2.000	125
10	5×11	0.525	270	5×11	0.750	290	5×11	0.800	165	6.3×11	1.200	205
22	5×11	0.525	290	5×11	0.500	310	6.3×11	0.500	265	8×11.5	0.600	355
33	5×11	0.450	310	6.3×11	0.300	405	6.3×11	0.500	265	10×12.5	0.250	450
47	6.3×11	0.330	460	6.3×11	0.300	460	8×11.5	0.300	500	8×15	0.300	500
										10×16	0.200	580
56	6.3×11	0.330	460	8×11.5	0.160	580	10×12.5	0.160	680	10×16	0.160	750
100	8×11.5	0.160	760	8×11.5	0.160	950	10×16	0.100	945	10×20	0.150	800
				8×15	0.108	960				12.5×20	0.100	1045
150	8×11.5	0.160	950	10×12.5	0.088	1280	10×20	0.080	1100	12.5×25	0.080	1195
220	8×15	0.098	1030	10×16	0.065	1785	12.5×20	0.070	1300	16×25	0.060	1600
	10×12.5	0.088	1280									
330	10×16	0.065	1785	10×20	0.050	2270	12.5×20	0.050	1495	16×31.5	0.040	1750
390	8×20	0.088	1830	10×20	0.050	2270	12.5×25	0.039	1600	16×31.5	0.040	1750
470	8×20	0.088	1930	12.5×20	0.043	2950	16×20	0.035	1990	18×40	0.030	2060
	10×16	0.065										
	10×20	0.050	2270									
680	10×20	0.050	2400	12.5×25	0.029	3460	16×25	0.030	2780			
	12.5×20	0.043	2950									
1000	12.5×20	0.043	3100	16×25	0.027	3890	16×35.5	0.020	2835			
	12.5×25	0.032	3460									
1500	12.5×25	0.029	3500	16×31.5	0.024	3900						
	16×20	0.027	3600									
	16×25	0.024	3890									
2200	16×31.5	0.024	3900	18×35.5	0.022	3950						
3300	18×35.5	0.022	3950									

## MZ Ultra Low Impedance Series

Low Impedance   
 Miniaturized   
 Solvent Proof

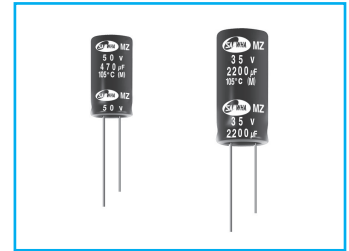

- Low impedance compared with MK series
- Enabled high ripple current by a reduction of impedance at high frequency
- High reliability withstanding 5000 hours load life at 105°C (2000~3000 hours for smaller case sizes as specified below)
- Complied to the RoHS directive



Item	Characteristics																	
Operating temperature range	-40 ~ +105°C																	
Leakage current max.	I = 0.01CV or 3µA whichever is greater (after 2 minutes) I = 0.03CV or 4µA whichever is greater (after 1 minute)																	
Capacitance tolerance	±20% at 120Hz, 20°C																	
Dissipation factor max. (at 120Hz, 20°C)	Capacitance > 1000µF : tanδ increases by 0.02 for each 1000µF from below value.																	
	<table border="1"> <tr> <td>WV</td> <td>6.3</td> <td>10</td> <td>16</td> <td>25</td> <td>35</td> <td>50</td> <td>63</td> <td>100</td> </tr> <tr> <td>tanδ</td> <td>0.22</td> <td>0.19</td> <td>0.16</td> <td>0.14</td> <td>0.12</td> <td>0.10</td> <td>0.09</td> <td>0.08</td> </tr> </table>	WV	6.3	10	16	25	35	50	63	100	tanδ	0.22	0.19	0.16	0.14	0.12	0.10	0.09
WV	6.3	10	16	25	35	50	63	100										
tanδ	0.22	0.19	0.16	0.14	0.12	0.10	0.09	0.08										
Low temperature characteristics (Impedance ratio at 120Hz)	Z-40°C / Z+20°C																	
	Z-25°C / Z+20°C																	
Load life	After an application of DC bias voltage plus the rated AC ripple current for 5000 hours at 105°C. The measurement shall meet the following limits. The DC voltage plus the peak AC voltage combined must not exceed the rated voltage.																	
	<table border="1"> <tr> <td>Leakage current</td> <td>Less than specified value</td> </tr> <tr> <td>Capacitance change</td> <td>Within ±25% of initial value</td> </tr> <tr> <td>tanδ</td> <td>Less than 200% of specified value</td> </tr> </table>	Leakage current	Less than specified value	Capacitance change	Within ±25% of initial value	tanδ	Less than 200% of specified value											
	Leakage current	Less than specified value																
	Capacitance change	Within ±25% of initial value																
tanδ	Less than 200% of specified value																	
<table border="1"> <tr> <td>∅D</td> <td>∅D = 5, 6.3</td> <td>∅D = 8</td> <td>∅D ≥ 10</td> </tr> <tr> <td>Life time</td> <td>2000 hours</td> <td>3000 hours</td> <td>5000 hours</td> </tr> </table>	∅D	∅D = 5, 6.3	∅D = 8	∅D ≥ 10	Life time	2000 hours	3000 hours	5000 hours										
∅D	∅D = 5, 6.3	∅D = 8	∅D ≥ 10															
Life time	2000 hours	3000 hours	5000 hours															
Shelf life (at 105°C)	After 1000 hours no load test, leakage current, capacitance and tanδ are same as load life value. The measurement shall be performed at 20°C by the KS C IEC 60384 - 4																	

### ● DRAWING

Unit : mm

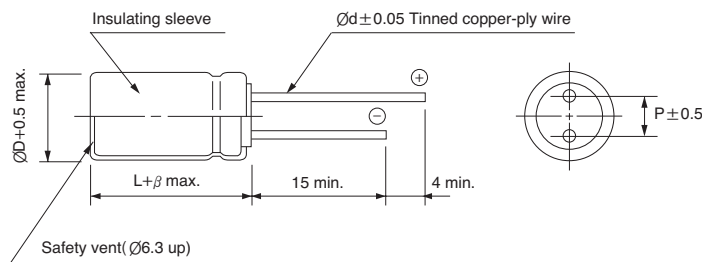

∅D	5	6.3	8	10	12.5	16	18
P	2.0	2.5	3.5	5.0	5.0	7.5	7.5
∅d	0.5	0.5	0.6	0.6	0.6	0.8	0.8
β	1.5			2.0			

### ● FREQUENCY COEFFICIENT OF PERMISSIBLE RIPPLE CURRENT

µF \ Frequency	120Hz	1kHz	10kHz	50kHz	100kHz ≤
~ 33	0.42	0.70	0.90	0.95	1.00
47 ~ 220	0.50	0.73	0.92	0.96	1.00
330 ~ 680	0.55	0.77	0.94	0.97	1.00
1000 ~ 1500	0.60	0.80	0.96	0.98	1.00
2200 ~	0.70	0.85	0.98	0.99	1.00

# MINIATURE ALUMINUM ELECTROLYTIC CAPACITORS

**MZ** series

● DIMENSIONS & MAXIMUM PERMISSIBLE RIPPLE CURRENT

WV Item μF	6.3			10			16			25		
	∅D×L (mm)	Impedance (Ω)max. 20°C 100kHz	Ripple current (mA rms) 105°C 100kHz	∅D×L (mm)	Impedance (Ω)max. 20°C 100kHz	Ripple current (mA rms) 105°C 100kHz	∅D×L (mm)	Impedance (Ω)max. 20°C 100kHz	Ripple current (mA rms) 105°C 100kHz	∅D×L (mm)	Impedance (Ω)max. 20°C 100kHz	Ripple current (mA rms) 105°C 100kHz
10							5×11	0.35	250	5×11	0.60	250
22	5×11	0.35	250	5×11	0.35	250	5×11	0.35	250	5×11	0.40	250
33	5×11	0.35	250	5×11	0.35	250	5×11	0.35	250	5×11	0.40	250
47	5×11	0.30	250	5×11	0.30	250	5×11	0.30	250	5×11	0.30	250
100	5×11	0.30	250	5×11	0.30	250	6.3×11	0.15	405	6.3×11	0.15	405
150	6.3×11	0.15	405	6.3×11	0.15	405	6.3×11	0.15	405	8×11.5	0.10	760
220	6.3×11	0.15	405	6.3×11	0.15	405	8×11.5	0.085	760	8×11.5	0.10	760
330	6.3×11	0.15	405	8×11.5	0.12	760	8×11.5	0.085	760	10×12.5	0.08	1030
470	8×11.5	0.072	760	8×11.5	0.10	760	10×12.5	0.053	1030	10×16	0.045	1430
680	10×12.5	0.053	1030	10×12.5	0.053	1030	10×16	0.038	1430	10×20	0.032	1820
1000	10×12.5	0.053	1030	10×16	0.038	1430	10×20	0.027	1820	12.5×20	0.025	2360
1500	10×20	0.027	1820	10×20	0.032	1820	12.5×20	0.025	2360	16×20	0.020	3460
2200	12.5×20	0.025	2360	12.5×20	0.025	2360	12.5×25	0.018	2770	16×25	0.015	3460
3300	12.5×20	0.025	2360	12.5×25	0.024	2770	16×25	0.015	3460	16×31.5	0.015	3680
4700	16×25	0.015	3460	16×25	0.015	3460	16×31.5	0.015	3680	18×35.5	0.014	3800
6800	16×25	0.015	3460	16×31.5	0.015	3680	18×35.5	0.014	3800			
10000	16×31.5	0.015	3680	18×35.5	0.014	3800						
15000	18×35.5	0.014	3800									

WV Item μF	35			50			63			100		
	∅D×L (mm)	Impedance (Ω)max. 20°C 100kHz	Ripple current (mA rms) 105°C 100kHz	∅D×L (mm)	Impedance (Ω)max. 20°C 100kHz	Ripple current (mA rms) 105°C 100kHz	∅D×L (mm)	Impedance (Ω)max. 20°C 100kHz	Ripple current (mA rms) 105°C 100kHz	∅D×L (mm)	Impedance (Ω)max. 20°C 100kHz	Ripple current (mA rms) 105°C 100kHz
1.0				5×11	2.0	250						
2.2				5×11	2.0	250				5×11	2.0	125
3.3				5×11	1.0	250	5×11	2.0	165	5×11	2.0	125
4.7	5×11	0.35	250	5×11	1.0	250	5×11	2.0	165	5×11	2.0	125
10	5×11	0.35	250	5×11	0.55	250	5×11	0.80	165	6.3×11	0.50	205
22	5×11	0.35	250	5×11	0.45	250	6.3×11	0.50	265	8×11.5	0.30	355
33	5×11	0.30	250	6.3×11	0.25	405	6.3×11	0.50	265	10×12.5	0.25	450
47	6.3×11	0.15	405	6.3×11	0.20	405	8×11.5	0.30	500	10×16	0.20	580
100	8×11.5	0.072	760	8×11.5	0.105	760	10×16	0.10	945	12.5×20	0.10	1045
150	8×11.5	0.072	760	10×12.5	0.061	1030	10×20	0.08	1100	12.5×25	0.070	1195
220	10×12.5	0.065	1030	10×20	0.038	1430	12.5×20	0.07	1300	16×25	0.060	1600
330	10×16	0.038	1430	10×20	0.032	1820	12.5×20	0.04	1495	16×31.5	0.040	1750
470	10×20	0.027	1820	12.5×20	0.027	2360	16×20	0.035	1990	18×40	0.030	2060
680	12.5×20	0.025	2360	12.5×25	0.022	2770	16×25	0.030	2780			
1000	12.5×25	0.022	2770	16×25	0.018	3460	16×35.5	0.020	2835			
1500	16×25	0.018	3460	16×31.5	0.015	3680						
2200	16×31.5	0.015	3680	18×35.5	0.014	3800						
3300	18×35.5	0.014	3800									

## KN Low Imp., High Ripple Current Series

Low Impedance   
 Miniaturized   
 Solvent Proof

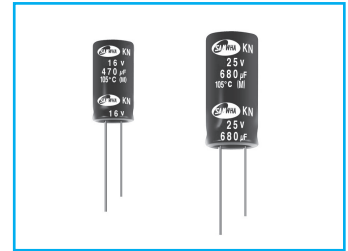

- High ripple current compared with MN series
- Enabled high ripple current by a reduction of impedance at high frequency range
- High reliability withstanding 5000 hours load life at 105°C
- Complied to the RoHS directive

→   
 High Ripple

Item	Characteristics											
Operating temperature range	-40 ~ +105°C											
Leakage current max.	I = 0.01CV or 3µA whichever is greater (after 2 minutes) I = 0.03CV or 4µA whichever is greater (after 1 minute)											
Capacitance tolerance	±20% at 120Hz, 20°C											
Dissipation factor max. (at 120Hz, 20°C)	Capacitance > 1000µF : tanδ increases by 0.02 for each 1000µF from below value.											
	<table border="1"> <thead> <tr> <th>WV</th> <th>10</th> <th>16</th> <th>25</th> <th>35</th> <th>50</th> </tr> </thead> <tbody> <tr> <td>tanδ</td> <td>0.19</td> <td>0.16</td> <td>0.14</td> <td>0.12</td> <td>0.10</td> </tr> </tbody> </table>	WV	10	16	25	35	50	tanδ	0.19	0.16	0.14	0.12
WV	10	16	25	35	50							
tanδ	0.19	0.16	0.14	0.12	0.10							
Low temperature characteristics (Impedance ratio at 120Hz)	Z-40°C / Z+20°C											
	Z-25°C / Z+20°C											
Load life	After an application of DC bias voltage plus the rated AC ripple current for 5000 hours at 105°C. The measurement shall meet the following limits. The DC voltage plus the peak AC voltage combined must not exceed the rated voltage.											
	Leakage current	Less than specified value										
	Capacitance change	Within ±25% of initial value										
	tanδ	Less than 200% of specified value										
	<table border="1"> <thead> <tr> <th>Case Size</th> <th>∅D ≤ 6.3</th> <th>∅D = 8</th> <th>∅D ≥ 10</th> </tr> </thead> <tbody> <tr> <td>Life time</td> <td>2000 hours</td> <td>3000 hours</td> <td>5000 hours</td> </tr> </tbody> </table>	Case Size	∅D ≤ 6.3	∅D = 8	∅D ≥ 10	Life time	2000 hours	3000 hours	5000 hours			
Case Size	∅D ≤ 6.3	∅D = 8	∅D ≥ 10									
Life time	2000 hours	3000 hours	5000 hours									
Shelf life (at 105°C)	After 1000 hours no load test, leakage current, capacitance and tanδ are same as load life value. The measurement shall be performed at 20°C by the KS C IEC 60384 - 4											

### DRAWING

Unit : mm

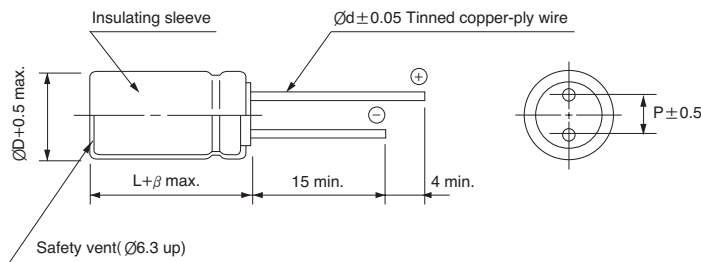

∅D	5	6.3	8	10	12.5
P	2.0	2.5	3.5	5.0	5.0
∅d	0.5	0.5	0.6	0.6	0.6
β	1.5		2.0		

### FREQUENCY COEFFICIENT OF PERMISSIBLE RIPPLE CURRENT

µF \ Frequency	120Hz	1kHz	10kHz	50kHz	100kHz ≤
~ 47	0.18	0.70	0.90	0.94	1.00
56 ~ 100	0.27	0.73	0.92	0.95	1.00
120 ~ 270	0.49	0.73	0.92	0.96	1.00
330 ~ 680	0.55	0.77	0.94	0.97	1.00
820 ~ 1500	0.60	0.80	0.96	0.98	1.00
2200 ~	0.70	0.85	0.98	0.99	1.00



# MINIATURE ALUMINUM ELECTROLYTIC CAPACITORS

**KN** series

● DIMENSIONS & MAXIMUM PERMISSIBLE RIPPLE CURRENT

WV Item μF	10			16			25		
	∅D×L (mm)	Impedance (Ω)max. 20°C 100kHz	Ripple current (mA rms) 105°C 100kHz	∅D×L (mm)	Impedance (Ω)max. 20°C 100kHz	Ripple current (mA rms) 105°C 100kHz	∅D×L (mm)	Impedance (Ω)max. 20°C 100kHz	Ripple current (mA rms) 105°C 100kHz
47							5 × 11	0.150	405
56				5 × 11	0.150	405	6.3 × 11	0.065	760
100	5 × 11	0.150	405	6.3 × 11	0.065	760	8 × 11.5	0.060	850
220	6.3 × 11	0.065	760	8 × 11.5	0.060	850	8 × 11.5	0.036	1000
330	8 × 11.5	0.060	850	8 × 11.5	0.036	1000	8 × 15	0.028	1250
							10 × 12.5	0.027	1430
470	8 × 11.5	0.036	1000	8 × 15	0.028	1250	8 × 20	0.020	1600
				10 × 12.5	0.027	1430	10 × 16	0.020	1820
680	8 × 15	0.028	1250	8 × 20	0.020	1600	10 × 20	0.014	2180
	10 × 12.5	0.027	1430	10 × 16	0.020	1820	12.5 × 16	0.018	2200
820	10 × 12.5	0.025	1500	10 × 16	0.018	2000	12.5 × 20	0.013	2360
1000	8 × 20	0.020	1600	10 × 20	0.014	2180	12.5 × 20	0.013	2480
	10 × 16	0.020	1820	12.5 × 16	0.018	2200			
1200	10 × 20	0.014	2180	12.5 × 20	0.013	2360	12.5 × 20	0.013	2600
	12.5 × 16	0.018	2200						
1500	12.5 × 20	0.013	2360	12.5 × 20	0.013	2480	12.5 × 25	0.012	2900
2200	12.5 × 20	0.013	2480	12.5 × 25	0.012	2900			
3300	12.5 × 25	0.012	3200						

WV Item μF	35			50		
	∅D×L (mm)	Impedance (Ω)max. 20°C 100kHz	Ripple current (mA rms) 105°C 100kHz	∅D×L (mm)	Impedance (Ω)max. 20°C 100kHz	Ripple current (mA rms) 105°C 100kHz
33	5 × 11	0.150	405			
47	6.3 × 11	0.100	550	6.3 × 11	0.140	405
56	6.3 × 11	0.065	760	6.3 × 11	0.140	580
100	8 × 11.5	0.050	850	8 × 11.5	0.072	760
150	8 × 11.5	0.036	1000	10 × 12.5	0.061	1030
220	8 × 15	0.028	1250	10 × 16	0.042	1430
	10 × 12.5	0.027	1430			
270	8 × 20	0.020	1600	12.5 × 16	0.042	1700
330	10 × 16	0.020	1820	10 × 20	0.030	1820
470	10 × 20	0.014	2180	12.5 × 20	0.027	2360
	12.5 × 16	0.018	2200			
560	12.5 × 20	0.015	2360	12.5 × 25	0.020	2500
680	12.5 × 20	0.015	2480			
1000	12.5 × 25	0.015	2900			

## RP Series

Low Impedance   
 Long Life   
 Solvent Proof

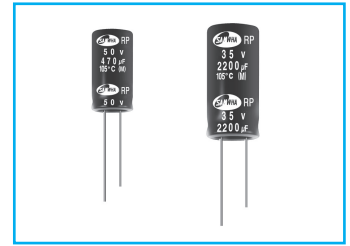

- High reliability long life(10000 hours)
- Operating temperature  $-55 \sim +105^{\circ}\text{C}$
- Enabled high ripple current by a reduction of impedance at high frequency
- Ideally suited for use in switching power supply, main board
- Complied to the RoHS directive

$\Rightarrow$

Item	Characteristics													
Operating temperature range	$-55 \sim +105^{\circ}\text{C}$													
Leakage current max.	$I = 0.01CV$ or $3\mu\text{A}$ whichever is greater (after 2 minutes)													
Capacitance tolerance	$\pm 20\%$ at 120Hz, $20^{\circ}\text{C}$													
Dissipation factor max. (at 120Hz, $20^{\circ}\text{C}$ )	Capacitance $> 1000\mu\text{F}$ : $\tan\delta$ increases by 0.02 for each $1000\mu\text{F}$ from below value.													
	<table border="1"> <tr> <td>WV</td> <td>6.3</td> <td>10</td> <td>16</td> <td>25</td> <td>35</td> <td>50</td> </tr> <tr> <td><math>\tan\delta</math></td> <td>0.22</td> <td>0.19</td> <td>0.16</td> <td>0.14</td> <td>0.12</td> <td>0.10</td> </tr> </table>	WV	6.3	10	16	25	35	50	$\tan\delta$	0.22	0.19	0.16	0.14	0.12
WV	6.3	10	16	25	35	50								
$\tan\delta$	0.22	0.19	0.16	0.14	0.12	0.10								
Low temperature characteristics (Impedance ratio at 120Hz)	<table border="1"> <tr> <td>WV</td> <td>6.3</td> <td>10</td> <td>16 ~ 25</td> <td>35 ~ 50</td> </tr> <tr> <td>Z-<math>55^{\circ}\text{C}</math>/Z+<math>20^{\circ}\text{C}</math></td> <td>3</td> <td>3</td> <td>3</td> <td>3</td> </tr> </table>	WV	6.3	10	16 ~ 25	35 ~ 50	Z- $55^{\circ}\text{C}$ /Z+ $20^{\circ}\text{C}$	3	3	3	3			
	WV	6.3	10	16 ~ 25	35 ~ 50									
Z- $55^{\circ}\text{C}$ /Z+ $20^{\circ}\text{C}$	3	3	3	3										
Load life	After an application of DC bias voltage plus the rated AC ripple current for 10000 hours at $105^{\circ}\text{C}$ . The measurement shall meet the following limits. The DC voltage plus the peak AC voltage combined must not exceed the rated voltage.													
	<table border="1"> <tr> <td>Leakage current</td> <td>Less than specified value</td> </tr> <tr> <td>Capacitance change</td> <td>Within <math>\pm 20\%</math> of initial value</td> </tr> <tr> <td><math>\tan\delta</math></td> <td>Less than 200% of specified value</td> </tr> </table>	Leakage current	Less than specified value	Capacitance change	Within $\pm 20\%$ of initial value	$\tan\delta$	Less than 200% of specified value							
	Leakage current	Less than specified value												
Capacitance change	Within $\pm 20\%$ of initial value													
$\tan\delta$	Less than 200% of specified value													
<table border="1"> <tr> <td><math>\varnothing D</math></td> <td><math>\varnothing D = 5, 6.3</math></td> <td><math>\varnothing D = 8</math></td> <td><math>\varnothing D = 10</math></td> <td><math>\varnothing D \geq 12.5</math></td> </tr> <tr> <td>Life time</td> <td>4000 hours</td> <td>6000 hours</td> <td>7000 hours</td> <td>10000 hours</td> </tr> </table>	$\varnothing D$	$\varnothing D = 5, 6.3$	$\varnothing D = 8$	$\varnothing D = 10$	$\varnothing D \geq 12.5$	Life time	4000 hours	6000 hours	7000 hours	10000 hours				
$\varnothing D$	$\varnothing D = 5, 6.3$	$\varnothing D = 8$	$\varnothing D = 10$	$\varnothing D \geq 12.5$										
Life time	4000 hours	6000 hours	7000 hours	10000 hours										
Shelf life (at $105^{\circ}\text{C}$ )	After 1000 hours no load test, leakage current, capacitance and $\tan\delta$ are same as load life value. The measurement shall be performed at $20^{\circ}\text{C}$ by the KS C IEC 60384 - 4													

### DRAWING

Unit : mm

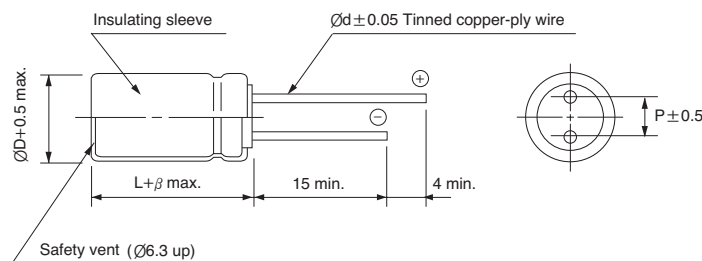

$\varnothing D$	5	6.3	8	10	12.5	16	18
P	2.0	2.5	3.5	5.0	5.0	7.5	7.5
$\varnothing d$	0.5	0.5	0.6	0.6	0.6	0.8	0.8
$\beta$	1.5			2.0			

### FREQUENCY COEFFICIENT OF PERMISSIBLE RIPPLE CURRENT

$\mu\text{F}$ \ Frequency	120Hz	1kHz	10kHz	50kHz	100kHz $\leq$
~ 33	0.40	0.65	0.82	0.91	1.00
47 ~ 270	0.50	0.70	0.84	0.92	1.00
330 ~ 680	0.55	0.75	0.86	0.93	1.00
820 ~ 1800	0.60	0.80	0.88	0.94	1.00
2200 ~	0.70	0.85	0.90	0.95	1.00

# MINIATURE ALUMINUM ELECTROLYTIC CAPACITORS

**RP** series

● DIMENSIONS & MAXIMUM PERMISSIBLE RIPPLE CURRENT

WV Item μF	6.3			10			16		
	∅D×L (mm)	Impedance (Ω)max. 20°C 100kHz	Ripple current (mA rms) 105°C 100kHz	∅D×L (mm)	Impedance (Ω)max. 20°C 100kHz	Ripple current (mA rms) 105°C 100kHz	∅D×L (mm)	Impedance (Ω)max. 20°C 100kHz	Ripple current (mA rms) 105°C 100kHz
47							5 × 11	0.65	180
68				5 × 11	0.65	180	6.3 × 11	0.30	280
100	5 × 11	0.65	180	5 × 11	0.65	180	6.3 × 11	0.30	280
150	5 × 11	0.65	280	6.3 × 11	0.30	280	6.3 × 11	0.30	280
220	6.3 × 11	0.30	280	6.3 × 11	0.30	280	8 × 11.5	0.14	450
330	6.3 × 11	0.30	280	8 × 11.5	0.14	450	8 × 11.5	0.14	450
470	8 × 11.5	0.14	450	8 × 11.5	0.14	450	10 × 12.5	0.10	660
680	10 × 12.5	0.10	660	10 × 12.5	0.10	660	10 × 16	0.08	850
1000	10 × 12.5	0.10	660	10 × 16	0.08	850	10 × 20	0.054	1100
1500	10 × 20	0.054	1100	10 × 20	0.054	1100	12.5 × 20	0.050	1400
2200	12.5 × 20	0.050	1400	12.5 × 20	0.050	1400	12.5 × 25	0.038	1700
3300	12.5 × 20	0.050	1400	12.5 × 25	0.038	1700	16 × 25	0.030	2100
4700	16 × 25	0.030	2100	16 × 31.5	0.030	2100	16 × 25	0.025	2600
6800	16 × 25	0.030	2100	16 × 31.5	0.025	2600	16 × 35.5	0.022	3000
10000	16 × 31.5	0.025	2600	18 × 35.5	0.022	3000			
15000	18 × 35.5	0.022	3000						

WV Item μF	25			35			50		
	∅D×L (mm)	Impedance (Ω)max. 20°C 100kHz	Ripple current (mA rms) 105°C 100kHz	∅D×L (mm)	Impedance (Ω)max. 20°C 100kHz	Ripple current (mA rms) 105°C 100kHz	∅D×L (mm)	Impedance (Ω)max. 20°C 100kHz	Ripple current (mA rms) 105°C 100kHz
1.0							5 × 11	3.5	40
2.2							5 × 11	3.0	55
3.3							5 × 11	2.6	65
4.7							5 × 11	2.3	90
6.8							5 × 11	1.4	120
10							5 × 11	1.4	120
22				5 × 11	0.70	180	5 × 11	1.2	150
33	5 × 11	0.70	180	5 × 11	0.65	180	6.3 × 11	0.85	200
47	5 × 11	0.65	180	6.3 × 11	0.30	280	6.3 × 11	0.70	250
68	6.3 × 11	0.30	280	8 × 11.5	0.14	450	8 × 11.5	0.24	340
100	6.3 × 11	0.30	280	8 × 11.5	0.14	450	8 × 11.5	0.24	340
150	8 × 11.5	0.14	450	8 × 11.5	0.14	450	10 × 12.5	0.17	490
220	8 × 11.5	0.14	450	10 × 12.5	0.10	660	10 × 16	0.12	650
330	10 × 12.5	0.10	660	10 × 16	0.080	850	10 × 20	0.10	810
470	10 × 16	0.080	850	10 × 20	0.054	1100	12.5 × 20	0.085	1100
680	10 × 20	0.054	1100	12.5 × 20	0.050	1400	12.5 × 25	0.065	1200
1000	12.5 × 20	0.050	1400	12.5 × 25	0.038	1700	16 × 31.5	0.043	1600
1500	16 × 25	0.030	1400	16 × 31.5	0.030	2100	16 × 31.5	0.038	2000
2200	16 × 25	0.030	2100	16 × 31.5	0.025	2600	18 × 35.5	0.034	2300
3300	16 × 31.5	0.025	2600	18 × 35.5	0.022	3000			
4700	18 × 35.5	0.022	3000						

# MINIATURE ALUMINUM ELECTROLYTIC CAPACITORS



## WF High ripple current, Extremely Low Impedance Series

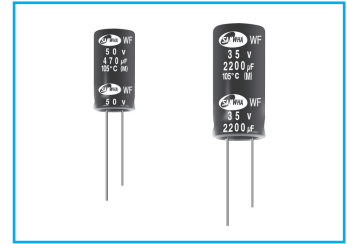

- Operating temperature range of  $-40 \sim +105^{\circ}\text{C}$
- Extremely low impedance at high frequency
- High reliability withstanding 10000 hours load life at  $105^{\circ}\text{C}$
- For E-meter
- Complied to the RoHS directive



Item	Characteristics																		
Operating temperature range	$-40 \sim +105^{\circ}\text{C}$																		
Leakage current max.	$I = 0.03\text{CV}$ or $3\mu\text{A}$ whichever is greater (after 2 minutes)																		
Capacitance tolerance	$\pm 20\%$ at 120Hz, $20^{\circ}\text{C}$																		
Dissipation factor max. (at 120Hz, $20^{\circ}\text{C}$ )	Capacitance $> 1000\mu\text{F}$ : $\tan\delta$ increases by 0.02 for each $1000\mu\text{F}$ from below value. <table border="1"> <tr> <td>WV</td> <td>6.3</td> <td>10</td> <td>16</td> <td>25</td> <td>35</td> <td>50</td> <td>63</td> <td>100</td> </tr> <tr> <td><math>\tan\delta</math></td> <td>0.22</td> <td>0.19</td> <td>0.16</td> <td>0.14</td> <td>0.12</td> <td>0.10</td> <td>0.09</td> <td>0.08</td> </tr> </table>	WV	6.3	10	16	25	35	50	63	100	$\tan\delta$	0.22	0.19	0.16	0.14	0.12	0.10	0.09	0.08
WV	6.3	10	16	25	35	50	63	100											
$\tan\delta$	0.22	0.19	0.16	0.14	0.12	0.10	0.09	0.08											
Low temperature characteristics (Impedance ratio at 120Hz)	<table border="1"> <tr> <td>WV</td> <td>6.3</td> <td>10</td> <td>16</td> <td>25 ~ 100</td> </tr> <tr> <td><math>Z_{-40^{\circ}\text{C}}/Z_{+20^{\circ}\text{C}}</math></td> <td>8</td> <td>6</td> <td>4</td> <td>3</td> </tr> </table>	WV	6.3	10	16	25 ~ 100	$Z_{-40^{\circ}\text{C}}/Z_{+20^{\circ}\text{C}}$	8	6	4	3								
WV	6.3	10	16	25 ~ 100															
$Z_{-40^{\circ}\text{C}}/Z_{+20^{\circ}\text{C}}$	8	6	4	3															
Load life	After an application of DC bias voltage plus the rated AC ripple current for 10000 hours at $105^{\circ}\text{C}$ . The measurement shall meet the following limits. The DC voltage plus the peak AC voltage combined must not exceed the rated voltage. <table border="1"> <tr> <td>Leakage current</td> <td>Less than specified value</td> </tr> <tr> <td>Capacitance change</td> <td>Within <math>\pm 25\%</math> of initial value</td> </tr> <tr> <td><math>\tan\delta</math></td> <td>Less than 200% of specified value</td> </tr> </table> <table border="1"> <tr> <td><math>\varnothing D</math></td> <td><math>\varnothing D = 5, 6.3</math></td> <td><math>\varnothing D = 8, 10</math></td> <td><math>\varnothing D \geq 12.5</math></td> </tr> <tr> <td>Life time</td> <td>5000 hours</td> <td>7000 hours</td> <td>10000 hours</td> </tr> </table>	Leakage current	Less than specified value	Capacitance change	Within $\pm 25\%$ of initial value	$\tan\delta$	Less than 200% of specified value	$\varnothing D$	$\varnothing D = 5, 6.3$	$\varnothing D = 8, 10$	$\varnothing D \geq 12.5$	Life time	5000 hours	7000 hours	10000 hours				
Leakage current	Less than specified value																		
Capacitance change	Within $\pm 25\%$ of initial value																		
$\tan\delta$	Less than 200% of specified value																		
$\varnothing D$	$\varnothing D = 5, 6.3$	$\varnothing D = 8, 10$	$\varnothing D \geq 12.5$																
Life time	5000 hours	7000 hours	10000 hours																
Shelf life (at $105^{\circ}\text{C}$ )	After 1000 hours no load test, leakage current, capacitance and $\tan\delta$ are same as load life value. The measurement shall be performed at $20^{\circ}\text{C}$ by the KS C IEC 60384 - 4																		

### DRAWING

Unit : mm

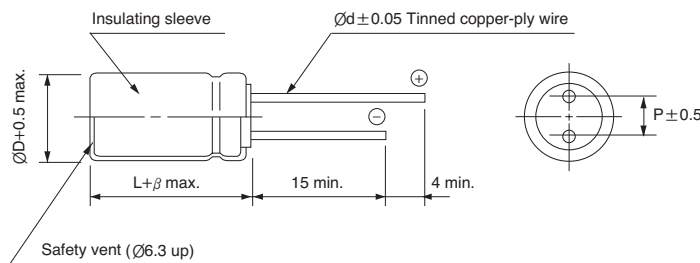

$\varnothing D$	5	6.3	8	10	12.5	16	18
P	2.0	2.5	3.5	5.0	5.0	7.5	7.5
$\varnothing d$	0.5	0.5	0.6	0.6	0.6	0.8	0.8
$\beta$	1.5			2.0			

### FREQUENCY COEFFICIENT OF PERMISSIBLE RIPPLE CURRENT

$\mu\text{F}$ \ Frequency	120Hz	1kHz	10kHz	50kHz	100kHz $\leq$
~ 33	0.40	0.65	0.82	0.91	1.00
47 ~ 220	0.50	0.70	0.84	0.92	1.00
330 ~ 470	0.55	0.75	0.86	0.93	1.00
~ 1000	0.60	0.80	0.88	0.94	1.00
2200 ~	0.70	0.85	0.90	0.95	1.00

# MINIATURE ALUMINUM ELECTROLYTIC CAPACITORS

**WF** series

● DIMENSIONS & MAXIMUM PERMISSIBLE RIPPLE CURRENT

WV Item μF	6.3			10			16			25		
	ØD×L (mm)	Impedance (Ω)max. 20°C 100kHz	Ripple current (mA rms) 105°C 100kHz	ØD×L (mm)	Impedance (Ω)max. 20°C 100kHz	Ripple current (mA rms) 105°C 100kHz	ØD×L (mm)	Impedance (Ω)max. 20°C 100kHz	Ripple current (mA rms) 105°C 100kHz	ØD×L (mm)	Impedance (Ω)max. 20°C 100kHz	Ripple current (mA rms) 105°C 100kHz
33										5×11	0.90	150
47							5×11	0.90	150	5×11	0.90	150
100	5×11	0.90	150	5×11	0.90	150	6.3×11	0.40	250	6.3×11	0.40	250
220	6.3×11	0.40	250	6.3×11	0.40	250	8×11.5	0.25	400	8×11.5	0.25	400
330	6.3×11	0.40	250	8×11.5	0.25	400	8×11.5	0.25	400	10×12.5	0.16	580
470	8×11.5	0.25	400	8×11.5	0.25	400	10×12.5	0.16	580	10×16	0.120	770
1000	10×12.5	0.16	580	10×16	0.120	770	10×20	0.078	1050	12.5×20	0.062	1300
2200	12.5×20	0.062	1300	12.5×20	0.062	1300	12.5×25	0.048	1650	16×25	0.034	1850
3300	12.5×20	0.062	1300	12.5×25	0.048	1650	16×25	0.034	1850	16×31.5	0.029	2000
4700	16×25	0.034	1850	16×25	0.034	1850	16×31.5	0.029	2000	18×35.5	0.025	2200
6800	16×25	0.034	1850	16×31.5	0.029	2000	18×35.5	0.025	2200			
10000	16×31.5	0.029	2000	18×35.5	0.025	2200						
15000	18×35.5	0.025	2200									

WV Item μF	35			50			63			100		
	ØD×L (mm)	Impedance (Ω)max. 20°C 100kHz	Ripple current (mA rms) 105°C 100kHz	ØD×L (mm)	Impedance (Ω)max. 20°C 100kHz	Ripple current (mA rms) 105°C 100kHz	ØD×L (mm)	Impedance (Ω)max. 20°C 100kHz	Ripple current (mA rms) 105°C 100kHz	ØD×L (mm)	Impedance (Ω)max. 20°C 100kHz	Ripple current (mA rms) 105°C 100kHz
1.0				5×11	4.0	50				5×11	4.5	20
2.2				5×11	2.5	55				5×11	3.0	30
3.3				5×11	2.2	65				5×11	2.7	40
4.7				5×11	1.9	88				5×11	2.5	65
10				5×11	1.5	100	5×11	2.3	87	6.3×11	1.2	140
22				5×11	0.9	150	6.3×11	1.30	140	8×11.5	0.63	160
33	5×11	0.90	150	6.3×11	0.40	250	6.3×11	1.20	140	10×12.5	0.43	230
47	6.3×11	0.4	250	6.3×11	0.4	400	8×11.5	0.63	210	10×12.5	0.43	230
										10×16	0.31	290
100	8×11.5	0.25	400	8×11.5	0.25	500	10×12.5	0.43	300	12.5×16	0.23	750
										12.5×20	0.16	
220	10×12.5	0.16	580	10×16	0.12	770	12.5×20	0.210	520	16×25	0.073	900
330	10×16	0.120	770	10×20	0.08	1050	12.5×20	0.160	660	16×25	0.073	900
390	10×20	0.095	900	10×20	0.075	1170	12.5×25	0.140	700	12.5×34.5	0.073	1650
470	10×20	0.078	1050	12.5×20	0.062	1300	12.5×25	0.120	750			
1000	12.5×25	0.048	1650	16×25	0.034	1850	16×31.5	0.054	1390			
2200	16×31.5	0.029	2000	18×35.5	0.025	2200						
3300	18×35.5	0.025	2200									

## LZ Low Impedance, Long Life Series

Low Impedance   
 Long Life   
 Solvent Proof

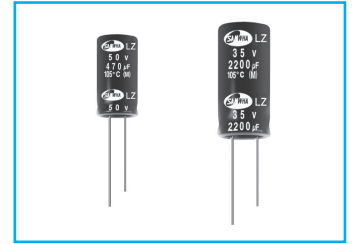

- Operating temperature range of -40 ~ +105°C
- Enabled high ripple current by a reduction of impedance at high frequency range
- High reliability withstanding 10000 hours load life at 105°C (6000/8000 hours for as specified below)
- Complied to the RoHS directive

$\rightleftharpoons$    
 Long life

Item	Characteristics													
Operating temperature range	-40 ~ +105°C													
Leakage current max.	I = 0.01CV or 3µA whichever is greater (after 2 minutes) I = 0.03CV or 4µA whichever is greater (after 1 minute)													
Capacitance tolerance	±20% at 120Hz, 20°C													
Dissipation factor max. (at 120Hz, 20°C)	Capacitance > 1000µF : tanδ increases by 0.02 for each 1000µF from below value.													
	<table border="1"> <tr> <td>WV</td> <td>6.3</td> <td>10</td> <td>16</td> <td>25</td> <td>35</td> <td>50</td> </tr> <tr> <td>tanδ</td> <td>0.22</td> <td>0.19</td> <td>0.16</td> <td>0.14</td> <td>0.12</td> <td>0.10</td> </tr> </table>	WV	6.3	10	16	25	35	50	tanδ	0.22	0.19	0.16	0.14	0.12
WV	6.3	10	16	25	35	50								
tanδ	0.22	0.19	0.16	0.14	0.12	0.10								
Low temperature characteristics (Impedance ratio at 120Hz)	Z-40°C / Z+20°C													
	Z-25°C / Z+20°C													
Load life	After an application of DC bias voltage plus the rated AC ripple current for 10000 hours at 105°C. The measurement shall meet the following limits. The DC voltage plus the peak AC voltage combined must not exceed the rated voltage.													
	<table border="1"> <tr> <td>Leakage current</td> <td>Less than specified value</td> </tr> <tr> <td>Capacitance change</td> <td>Within ±25% of initial value</td> </tr> <tr> <td>tanδ</td> <td>Less than 200% of specified value</td> </tr> </table>	Leakage current	Less than specified value	Capacitance change	Within ±25% of initial value	tanδ	Less than 200% of specified value							
	Leakage current	Less than specified value												
	Capacitance change	Within ±25% of initial value												
tanδ	Less than 200% of specified value													
<table border="1"> <tr> <td>∅D</td> <td>∅D = 5, 6.3</td> <td>∅D = 8</td> <td>∅D ≥ 10</td> </tr> <tr> <td>Life time</td> <td>6000 hours</td> <td>8000 hours</td> <td>10000 hours</td> </tr> </table>	∅D	∅D = 5, 6.3	∅D = 8	∅D ≥ 10	Life time	6000 hours	8000 hours	10000 hours						
∅D	∅D = 5, 6.3	∅D = 8	∅D ≥ 10											
Life time	6000 hours	8000 hours	10000 hours											
Shelf life (at 105°C)	After 1000 hours no load test, leakage current, capacitance and tanδ are same as load life value. The measurement shall be performed at 20°C by the KS C IEC 60384 - 4													

### ● DRAWING

Unit : mm

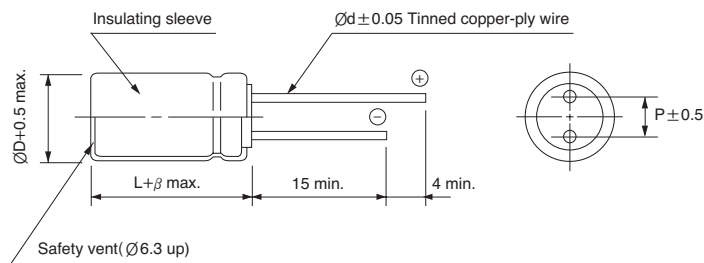

∅D	5	6.3	8	10	12.5	16	18
P	2.0	2.5	3.5	5.0	5.0	7.5	7.5
∅d	0.5	0.5	0.6	0.6	0.6	0.8	0.8
β	1.5			2.0			

### ● FREQUENCY COEFFICIENT OF PERMISSIBLE RIPPLE CURRENT

µF \ Frequency	120Hz	1kHz	10kHz	50kHz	100kHz
~ 33	0.32	0.60	0.80	0.90	1.00
47 ~ 270	0.40	0.63	0.82	0.91	1.00
330 ~ 680	0.45	0.67	0.84	0.92	1.00
820 ~ 1800	0.50	0.70	0.86	0.93	1.00
2200 ~	0.60	0.75	0.88	0.94	1.00

# MINIATURE ALUMINUM ELECTROLYTIC CAPACITORS

**LZ** series

● DIMENSIONS & MAXIMUM PERMISSIBLE RIPPLE CURRENT

WV Item μF	6.3			10			16		
	ØD×L (mm)	Impedance (Ω)max. 20°C	Ripple current (mA rms) 105°C	ØD×L (mm)	Impedance (Ω)max. 20°C	Ripple current (mA rms) 105°C	ØD×L (mm)	Impedance (Ω)max. 20°C	Ripple current (mA rms) 105°C
		100kHz	100kHz		100kHz	100kHz		100kHz	
47	5 × 11	0.600	300	5 × 11	0.600	300	5 × 11	0.600	300
100	5 × 11	0.600	345	5 × 11	0.600	345	6.3 × 11	0.300	345
150	6.3 × 11	0.300	345	6.3 × 11	0.300	345	6.3 × 11	0.300	540
220	6.3 × 11	0.300	345	6.3 × 11	0.300	345	8 × 11.5	0.200	540
330	6.3 × 11	0.300	540	8 × 11.5	0.250	608	8 × 11.5	0.200	945
470	8 × 11.5	0.140	540	8 × 11.5	0.200	630	10 × 12.5	0.105	945
680	10 × 12.5	0.105	945	10 × 12.5	0.105	945	8 × 20	0.105	945
820	10 × 12.5	0.105	945	10 × 16	0.075	945	10 × 16	0.075	1250
1000	10 × 16	0.075	1250	8 × 20	0.105	945	8 × 20	0.075	1250
				10 × 12.5	0.105	945	10 × 20	0.054	1760
				10 × 16	0.075	1250			
				10 × 20	0.054	1650			
1200	10 × 16	0.075	1500	10 × 16	0.075	1760	10 × 20	0.054	1960
1500	10 × 20	0.054	1760	10 × 20	0.054	1760	12.5 × 20	0.050	1960
1800	10 × 20	0.054	1760	10 × 20	0.054	1760	12.5 × 20	0.050	2250
2200	12.5 × 20	0.050	1960	12.5 × 20	0.050	1960	12.5 × 25	0.040	2480
2700	12.5 × 20	0.050	2250	12.5 × 25	0.040	2250	12.5 × 25	0.040	2900
3300	12.5 × 20	0.050	2480	12.5 × 25	0.040	2480	16 × 25	0.030	3250
3900	12.5 × 25	0.040	2480	16 × 25	0.030	2480	16 × 25	0.030	3570
4700	16 × 25	0.030	3250	16 × 25	0.030	3250	16 × 31.5	0.027	3630
5600	16 × 25	0.030	3570	16 × 25	0.030	3570			
6800	16 × 25	0.030	3630	16 × 31.5	0.027	3630			
8200	16 × 31.5	0.027	3700	18 × 35.5	0.025	3700			

WV Item μF	25			35			50		
	ØD×L (mm)	Impedance (Ω)max. 20°C	Ripple current (mA rms) 105°C	ØD×L (mm)	Impedance (Ω)max. 20°C	Ripple current (mA rms) 105°C	ØD×L (mm)	Impedance (Ω)max. 20°C	Ripple current (mA rms) 105°C
		100kHz	100kHz		100kHz	100kHz		100kHz	
10							5 × 11	3.000	160
22							5 × 11	1.800	240
33							5 × 11	1.800	292
47				6.3 × 11	0.450	345	6.3 × 11	1.000	450
56				6.3 × 11	0.450	345	6.3 × 11	0.700	450
68	6.3 × 11	0.400	345	6.3 × 11	0.450	345	8 × 11.5	0.500	490
100	6.3 × 11	0.400	345	6.3 × 11	0.350	500	8 × 11.5	0.300	724
				8 × 11.5	0.300	540			
120	6.3 × 11	0.400	345	8 × 11.5	0.250	540	8 × 11.5	0.200	950
150	8 × 11.5	0.250	740	8 × 11.5	0.250	945	10 × 12.5	0.120	979
180	8 × 11.5	0.200	740	8 × 11.5	0.190	945	8 × 20	0.120	1200
							10 × 12.5	0.120	1190
220	8 × 11.5	0.180	740	8 × 11.5	0.190	945	8 × 20	0.120	1370
				10 × 12.5	0.105	945	10 × 16	0.075	1370
270	10 × 12.5	0.105	945	8 × 15	0.120	945	10 × 20	0.064	1580
				10 × 16	0.085	1250			
330	10 × 12.5	0.105	945	10 × 16	0.085	1330	10 × 20	0.064	1870
390	8 × 15	0.135	1250	10 × 20	0.054	1500	10 × 20	0.064	2050
	10 × 12.5	0.105	1250						
470	10 × 16	0.075	1330	8 × 20	0.095	1430	12.5 × 20	0.050	2050
				10 × 16	0.085	1600			
				10 × 20	0.054	1760			
560	8 × 20	0.075	1700	12.5 × 20	0.050	1960	12.5 × 25	0.040	2410
	10 × 20	0.054							
680	10 × 16	0.075	1760	10 × 20	0.054	1850	12.5 × 25	0.040	2410
	10 × 20	0.054							
820	10 × 20	0.054	2300	12.5 × 25	0.040	2350	16 × 20	0.040	2730
	12.5 × 20	0.050							
1000	12.5 × 20	0.050	2350	12.5 × 25	0.040	2480	16 × 25	0.036	3010
1200	12.5 × 20	0.050	2480	16 × 20	0.040	2900			
1500	16 × 20	0.040	2480	16 × 25	0.030	3250			
1800	16 × 20	0.040	2900	16 × 25	0.030	3570			
2200	12.5 × 30	0.040	2900	16 × 31.5	0.027	3630			
	16 × 25	0.030	3250						
2700	16 × 25	0.030	3570						
3300	16 × 31.5	0.027	3630						

# MINIATURE ALUMINUM ELECTROLYTIC CAPACITORS



## ML Ultra Low Impedance, Long Life Series

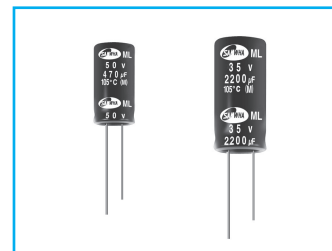

- Long Life compared with MZ series
- Enabled high ripple current by a reduction of impedance at high frequency
- High reliability withstanding 10000 hours load life at 105°C (6000/8000 hours for as specified below)
- Complied to the RoHS directive



Item	Characteristics																	
Operating temperature range	-40 ~ +105°C																	
Leakage current max.	I = 0.01CV or 3µA whichever is greater (after 2 minutes) I = 0.03CV or 4µA whichever is greater (after 1 minute)																	
Capacitance tolerance	±20% at 120Hz, 20°C																	
Dissipation factor max. (at 120Hz, 20°C)	Capacitance > 1000µF : tanδ increases by 0.02 for each 1000µF from below value.																	
	<table border="1"> <tr> <td>WV</td> <td>6.3</td> <td>10</td> <td>16</td> <td>25</td> <td>35</td> <td>50</td> <td>63</td> <td>100</td> </tr> <tr> <td>tanδ</td> <td>0.22</td> <td>0.19</td> <td>0.16</td> <td>0.14</td> <td>0.12</td> <td>0.10</td> <td>0.09</td> <td>0.08</td> </tr> </table>	WV	6.3	10	16	25	35	50	63	100	tanδ	0.22	0.19	0.16	0.14	0.12	0.10	0.09
WV	6.3	10	16	25	35	50	63	100										
tanδ	0.22	0.19	0.16	0.14	0.12	0.10	0.09	0.08										
Low temperature characteristics (Impedance ratio at 120Hz)	Z-40°C / Z+20°C																	
	Z-25°C / Z+20°C																	
Load life	After an application of DC bias voltage plus the rated AC ripple current for 10000 hours at 105°C. The measurement shall meet the following limits. The DC voltage plus the peak AC voltage combined must not exceed the rated voltage.																	
	<table border="1"> <tr> <td>Leakage current</td> <td>Less than specified value</td> </tr> <tr> <td>Capacitance change</td> <td>Within ±25% of initial value</td> </tr> <tr> <td>tanδ</td> <td>Less than 200% of specified value</td> </tr> </table>	Leakage current	Less than specified value	Capacitance change	Within ±25% of initial value	tanδ	Less than 200% of specified value											
	Leakage current	Less than specified value																
	Capacitance change	Within ±25% of initial value																
tanδ	Less than 200% of specified value																	
<table border="1"> <tr> <td>∅D</td> <td>∅D = 5, 6.3</td> <td>∅D = 8</td> <td>∅D ≥ 10</td> </tr> <tr> <td>Life time</td> <td>6000 hours</td> <td>8000 hours</td> <td>10000 hours</td> </tr> </table>	∅D	∅D = 5, 6.3	∅D = 8	∅D ≥ 10	Life time	6000 hours	8000 hours	10000 hours										
∅D	∅D = 5, 6.3	∅D = 8	∅D ≥ 10															
Life time	6000 hours	8000 hours	10000 hours															
Shelf life (at 105°C)	After 1000 hours no load test, leakage current, capacitance and tanδ are same as load life value. The measurement shall be performed at 20°C by the KS C IEC 60384 - 4																	

### DRAWING

Unit : mm

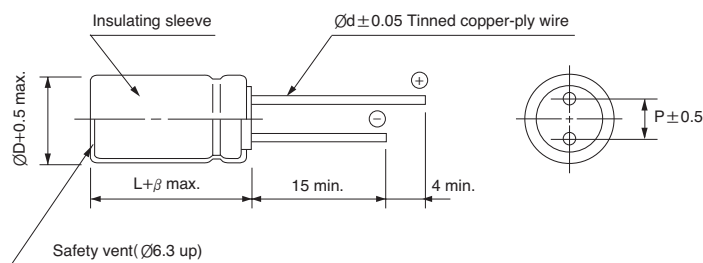

∅D	5	6.3	8	10	12.5	16	18
P	2.0	2.5	3.5	5.0	5.0	7.5	7.5
∅d	0.5	0.5	0.6	0.6	0.6	0.8	0.8
β	1.5			2.0			

### FREQUENCY COEFFICIENT OF PERMISSIBLE RIPPLE CURRENT

µF \ Frequency	120Hz	1kHz	10kHz	50kHz	100kHz ≤
~ 33	0.42	0.70	0.90	0.95	1.00
47 ~ 220	0.50	0.73	0.92	0.96	1.00
330 ~ 680	0.55	0.77	0.94	0.97	1.00
1000 ~ 1500	0.60	0.80	0.96	0.98	1.00
2200 ~	0.70	0.85	0.98	0.99	1.00

MINIATURE TYPES



# MINIATURE ALUMINUM ELECTROLYTIC CAPACITORS

**ML** series

● DIMENSIONS & MAXIMUM PERMISSIBLE RIPPLE CURRENT

WV Item μF	6.3			10			16			25		
	ØD×L (mm)	Impedance (Ω)max. 20°C 100kHz	Ripple current (mA rms) 105°C 100kHz	ØD×L (mm)	Impedance (Ω)max. 20°C 100kHz	Ripple current (mA rms) 105°C 100kHz	ØD×L (mm)	Impedance (Ω)max. 20°C 100kHz	Ripple current (mA rms) 105°C 100kHz	ØD×L (mm)	Impedance (Ω)max. 20°C 100kHz	Ripple current (mA rms) 105°C 100kHz
10							5×11	0.45	250	5×11	0.65	250
22	5×11	0.35	250	5×11	0.35	250	5×11	0.45	250	5×11	0.50	250
33	5×11	0.35	250	5×11	0.35	250	5×11	0.45	250	5×11	0.45	250
47	5×11	0.30	250	5×11	0.30	250	5×11	0.45	250	5×11	0.40	250
100	5×11	0.30	250	5×11	0.30	250	6.3×11	0.25	405	6.3×11	0.20	405
150	6.3×11	0.15	405	6.3×11	0.15	405	6.3×11	0.20	405	8×11.5	0.14	760
220	6.3×11	0.15	405	6.3×11	0.15	405	8×11.5	0.15	760	8×11.5	0.12	760
330	6.3×11	0.15	405	8×11.5	0.13	760	8×11.5	0.10	760	10×12.5	0.055	1030
390	6.3×11	0.15	405	8×11.5	0.11	760	8×11.5	0.10	760	8×15	0.072	1250
470	8×11.5	0.11	630	8×11.5	0.11	760	10×12.5	0.053	1030	10×12.5	0.055	1330
560	8×11.5	0.11	760	10×12.5	0.053	900	10×12.5	0.053	1100	8×20	0.072	1800
680	10×12.5	0.053	1030	10×12.5	0.053	1030	10×16	0.038	1430	10×16	0.040	1760
1000	10×12.5	0.053	1030	10×12.5	0.053	1330	10×16	0.038	1760	10×20	0.033	1960
1500	10×20	0.027	1820	10×20	0.030	1820	10×20	0.030	1960	12.5×20	0.029	2550
2200	12.5×20	0.025	2360	12.5×20	0.027	2360	12.5×25	0.023	2770	16×20	0.022	3250
3300	12.5×20	0.025	2360	12.5×20	0.027	2480	16×20	0.020	3250	16×25	0.018	3630
4700	16×25	0.015	3460	16×20	0.022	3250	16×25	0.018	3630			
6800	16×25	0.015	3460	16×25	0.018	3630						
10000	16×31.5	0.015	3680	18×31.5	0.015	3700						

WV Item μF	35			50			63			100		
	ØD×L (mm)	Impedance (Ω)max. 20°C 100kHz	Ripple current (mA rms) 105°C 100kHz	ØD×L (mm)	Impedance (Ω)max. 20°C 100kHz	Ripple current (mA rms) 105°C 100kHz	ØD×L (mm)	Impedance (Ω)max. 20°C 100kHz	Ripple current (mA rms) 105°C 100kHz	ØD×L (mm)	Impedance (Ω)max. 20°C 100kHz	Ripple current (mA rms) 105°C 100kHz
10	5×11	0.55	250	5×11	0.60	250	5×11	1.00	165	6.3×11	0.80	205
22	5×11	0.50	250	5×11	0.45	250	6.3×11	0.53	265	8×11.5	0.45	355
33	5×11	0.45	250	6.3×11	0.25	405	6.3×11	0.45	265	10×12.5	0.25	450
47	6.3×11	0.30	405	6.3×11	0.20	405	8×11.5	0.20	500	10×12.5	0.20	580
56	6.3×11	0.20	405	6.3×11	0.20	405	8×11.5	0.17	540	10×16	0.20	630
68	8×11.5	0.10	540	8×11.5	0.15	540	10×12.5	0.15	760	10×16	0.20	700
100	8×11.5	0.10	760	8×11.5	0.12	760	10×12.5	0.160	825	10×20	0.18	800
										12.5×16	0.110	975
150	8×11.5	0.10	760	10×12.5	0.061	1030	8×20	0.120	1200	12.5×20	0.090	1195
							10×20	0.080				
220	10×12.5	0.053	1030	10×16	0.038	1430	12.5×20	0.070	1300	16×25	0.060	1600
330	10×12.5	0.053	1330	10×20	0.032	1820	12.5×20	0.050	1495	16×25	0.040	1750
470	8×20	0.038	1600	12.5×20	0.030	2360	12.5×25	0.040	1990	18×31.5	0.035	2060
	10×16	0.041	1760									
680	12.5×20	0.026	2360	12.5×25	0.022	2770	16×25	0.030	2780			
1000	12.5×20	0.026	2480	16×25	0.018	3460	16×35.5	0.020	2835			
1500	16×20	0.022	3250	16×31.5	0.015	3680						
2200	16×25	0.018	3630				18×40	0.02	3500			

# MINIATURE ALUMINUM ELECTROLYTIC CAPACITORS



## LQ Low Imp., High Ripple Current Series

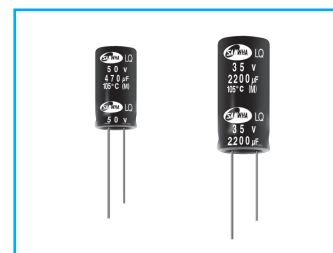

- For LED Lighting
- High reliability withstanding 10000 hours load life at 105°C (6000 ~ 9000 hours for smaller case sizes as specified below)
- Complied to the RoHS directive

Item	Characteristics																														
Operating temperature range	-40 ~ +105°C																														
Leakage current max.	$I = 0.01CV$ or $3\mu A$ whichever is greater (after 2 minutes)																														
Capacitance tolerance	$\pm 20\%$ at 120Hz, 20°C																														
Dissipation factor max. (at 120Hz, 20°C)	Capacitance > 1000 $\mu F$ : $\tan\delta$ increases by 0.02 for each 1000 $\mu F$ from below value.																														
	<table border="1"> <thead> <tr> <th>WV</th> <th>6.3</th> <th>10</th> <th>16</th> <th>25</th> <th>35</th> <th>50</th> <th>63</th> <th>80</th> <th>100</th> <th>120</th> </tr> </thead> <tbody> <tr> <td><math>\tan\delta</math></td> <td>0.22</td> <td>0.19</td> <td>0.16</td> <td>0.14</td> <td>0.12</td> <td>0.10</td> <td>0.09</td> <td>0.08</td> <td>0.08</td> <td>0.08</td> </tr> </tbody> </table>	WV	6.3	10	16	25	35	50	63	80	100	120	$\tan\delta$	0.22	0.19	0.16	0.14	0.12	0.10	0.09	0.08	0.08	0.08								
WV	6.3	10	16	25	35	50	63	80	100	120																					
$\tan\delta$	0.22	0.19	0.16	0.14	0.12	0.10	0.09	0.08	0.08	0.08																					
Low temperature characteristics (Impedance ratio at 120Hz)	Z-25°C / Z+20°C	2																													
	Z-40°C / Z+20°C	3																													
Load life	After an application of DC bias voltage plus the rated AC ripple current for 10000 hours at 105°C. The measurement shall meet the following limits. The DC voltage plus the peak AC voltage combined must not exceed the rated voltage.																														
	<table border="1"> <thead> <tr> <th>Rated voltage (Vdc)</th> <th>6.3 ~ 10</th> <th>16 ~ 120</th> </tr> </thead> <tbody> <tr> <td>Capacitance change</td> <td>Within <math>\pm 30\%</math> of initial value</td> <td>Within <math>\pm 25\%</math> of initial value</td> </tr> <tr> <td><math>\tan\delta</math></td> <td colspan="2">Less than 200% of specified value</td> </tr> <tr> <td>Leakage current</td> <td colspan="2">Less than specified value</td> </tr> </tbody> </table>	Rated voltage (Vdc)	6.3 ~ 10	16 ~ 120	Capacitance change	Within $\pm 30\%$ of initial value	Within $\pm 25\%$ of initial value	$\tan\delta$	Less than 200% of specified value		Leakage current	Less than specified value																			
	Rated voltage (Vdc)	6.3 ~ 10	16 ~ 120																												
	Capacitance change	Within $\pm 30\%$ of initial value	Within $\pm 25\%$ of initial value																												
	$\tan\delta$	Less than 200% of specified value																													
	Leakage current	Less than specified value																													
<table border="1"> <thead> <tr> <th rowspan="2"><math>\varnothing D</math></th> <th colspan="3">Life time (hrs)</th> </tr> <tr> <th>6.3Vdc</th> <th>10 ~ 50Vdc</th> <th>63 ~ 120Vdc</th> </tr> </thead> <tbody> <tr> <td><math>\varnothing 5 \sim \varnothing 6.3</math></td> <td>6000</td> <td>7000</td> <td>6000</td> </tr> <tr> <td><math>\varnothing 8 \times 11.5L</math></td> <td>8000</td> <td>9000</td> <td>8000</td> </tr> <tr> <td><math>\varnothing 8 \times 15L \sim 20L</math></td> <td>9000</td> <td>10000</td> <td>9000</td> </tr> <tr> <td><math>\varnothing 10 \times 12.5L</math></td> <td colspan="3">9000</td> </tr> <tr> <td><math>\varnothing 10 \times 16L \sim 25L</math></td> <td colspan="3">10000</td> </tr> <tr> <td><math>\varnothing 12.5 \sim</math></td> <td colspan="3">10000</td> </tr> </tbody> </table>	$\varnothing D$	Life time (hrs)			6.3Vdc	10 ~ 50Vdc	63 ~ 120Vdc	$\varnothing 5 \sim \varnothing 6.3$	6000	7000	6000	$\varnothing 8 \times 11.5L$	8000	9000	8000	$\varnothing 8 \times 15L \sim 20L$	9000	10000	9000	$\varnothing 10 \times 12.5L$	9000			$\varnothing 10 \times 16L \sim 25L$	10000			$\varnothing 12.5 \sim$	10000		
$\varnothing D$		Life time (hrs)																													
	6.3Vdc	10 ~ 50Vdc	63 ~ 120Vdc																												
$\varnothing 5 \sim \varnothing 6.3$	6000	7000	6000																												
$\varnothing 8 \times 11.5L$	8000	9000	8000																												
$\varnothing 8 \times 15L \sim 20L$	9000	10000	9000																												
$\varnothing 10 \times 12.5L$	9000																														
$\varnothing 10 \times 16L \sim 25L$	10000																														
$\varnothing 12.5 \sim$	10000																														
Shelf life (at 105°C)	After 1000 hours no load test, leakage current, capacitance and $\tan\delta$ are same as load life value. The measurement shall be performed at 20°C by the KS C IEC 60384 - 4																														

### ● DRAWING

Unit : mm

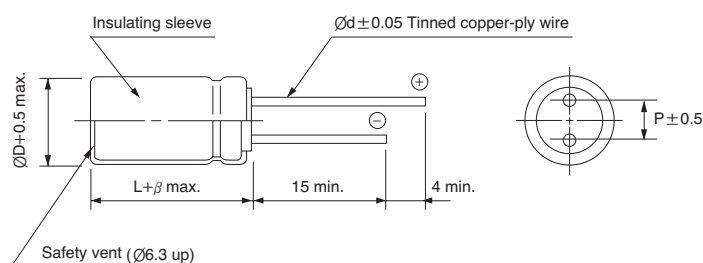

$\varnothing D$	5	6.3	8	10	12.5	16	18
P	2.0	2.5	3.5	5.0	5.0	7.5	7.5
$\varnothing d$	0.5	0.5	0.6	0.6	0.6	0.8	0.8
$\beta$	1.5			2.0			

### ● FREQUENCY COEFFICIENT OF PERMISSIBLE RIPPLE CURRENT

$\mu F$ \ Frequency	120Hz	1kHz	10kHz	50kHz	100kHz $\leq$
~ 33	0.42	0.70	0.90	0.95	1.00
47 ~ 270	0.50	0.73	0.92	0.96	1.00
330 ~ 680	0.55	0.77	0.94	0.97	1.00
820 ~ 1800	0.60	0.80	0.96	0.98	1.00
2200 ~	0.70	0.85	0.98	0.99	1.00

# MINIATURE ALUMINUM ELECTROLYTIC CAPACITORS

**LQ** series

● DIMENSIONS & MAXIMUM PERMISSIBLE RIPPLE CURRENT

WV Item μF	6.3			10			16			25			35		
	ØD×L (mm)	IMP. (Ω)max. 20°C 100kHz	Ripple current (mA rms) 105°C 100kHz	ØD×L (mm)	IMP. (Ω)max. 20°C 100kHz	Ripple current (mA rms) 105°C 100kHz	ØD×L (mm)	IMP. (Ω)max. 20°C 100kHz	Ripple current (mA rms) 105°C 100kHz	ØD×L (mm)	IMP. (Ω)max. 20°C 100kHz	Ripple current (mA rms) 105°C 100kHz	ØD×L (mm)	IMP. (Ω)max. 20°C 100kHz	Ripple current (mA rms) 105°C 100kHz
100									5 × 11	0.400	450	6.3 × 11	0.170	700	
120									5 × 11	0.400	450				
150				5 × 11	0.400	450						6.3 × 11	0.170	700	
180														8 × 11.5 0.075 1200	
220	5 × 11	0.400	345											8 × 15 0.065 1600	
270														10 × 12.5 0.053 1700	
330				6.3 × 11	0.170	700						8 × 11.5	0.090	1200	
390												8 × 15	0.065	1600	
470	6.3 × 11	0.170	540									10 × 12.5	0.053	1700	
560				8 × 11.5	0.110	1200	8 × 15	0.059	1600	8 × 20	0.041	1960	10 × 16	0.038	2000
680				8 × 15	0.059	1600	10 × 12.5	0.053	1700	10 × 16	0.039	2000	10 × 20	0.030	2500
820	8 × 11.5	0.075	945	10 × 12.5	0.053	1700	8 × 20	0.041	1960				12.5 × 20	0.027	2600
1000	8 × 15	0.059	1250	10 × 16	0.041	1960	10 × 16	0.036	2000				12.5 × 20	0.025	2900
1200	10 × 12.5	0.053	1500	10 × 16	0.036	2000						12.5 × 20	0.028	2900	
1500	8 × 20	0.041	1500				10 × 20	0.027	2500	12.5 × 20	0.026	2900	12.5 × 25	0.022	3200
1800	10 × 16	0.036	1760	10 × 20	0.027	2500	12.5 × 20	0.024	2600	12.5 × 25	0.024	3200	12.5 × 30	0.017	3660
2200				12.5 × 20	0.027	2900	12.5 × 20	0.023	2900	12.5 × 30	0.017	3660	16 × 20	0.020	3330
2700	10 × 20	0.027	1960	12.5 × 20	0.024	3000	12.5 × 25	0.018	3200						
3300	12.5 × 20	0.023	2250	12.5 × 25	0.022	3200	12.5 × 30	0.017	3660	16 × 20	0.020	3300	16 × 25	0.016	3810
3900	12.5 × 20	0.024	2480												
4700	12.5 × 25	0.018	2900	12.5 × 30	0.018	3660	16 × 25	0.016	3810						
5600	12.5 × 30	0.017	3450	16 × 25	0.016	3810									
6800	16 × 20	0.020	3250												
8200	16 × 25	0.016	3630												

WV Item μF	50			63			80			100			120		
	ØD×L (mm)	IMP. (Ω)max. 20°C 100kHz	Ripple current (mA rms) 105°C 100kHz	ØD×L (mm)	IMP. (Ω)max. 20°C 100kHz	Ripple current (mA rms) 105°C 100kHz	ØD×L (mm)	IMP. (Ω)max. 20°C 100kHz	Ripple current (mA rms) 105°C 100kHz	ØD×L (mm)	IMP. (Ω)max. 20°C 100kHz	Ripple current (mA rms) 105°C 100kHz	ØD×L (mm)	IMP. (Ω)max. 20°C 100kHz	Ripple current (mA rms) 105°C 100kHz
27	5 × 11	0.480	310				6.3 × 11	0.460	370						
33										8 × 11.5	0.450	620	8 × 15	0.200	780
47	6.3 × 11	0.380	400	6.3 × 11	0.350	420	8 × 11.5	0.290	620	8 × 15	0.350	780	8 × 20	0.160	1040
56	6.3 × 11	0.220	500							10 × 12.5	0.250	780	10 × 16	0.110	1040
68							8 × 15	0.200	780	10 × 12.5	0.250	780			
82							10 × 12.5	0.170	780	8 × 20	0.250	1040	10 × 20	0.084	1430
100	8 × 11.5	0.120	950	8 × 15	0.180	990	10 × 16	0.140	1040	10 × 16	0.130	1040	12.5 × 16	0.110	1430
120	8 × 15	0.082	1230	10 × 12.5	0.110	990				10 × 20	0.105	1430	10 × 16	0.130	1040
150	10 × 12.5	0.073	1280	8 × 20	0.096	1200	10 × 20	0.084	1430	12.5 × 16	0.105	1430	12.5 × 20	0.062	1750
180	8 × 20	0.065	1580	10 × 16	0.076	1200	12.5 × 16	0.110	1430	12.5 × 20	0.075	1620	12.5 × 25	0.047	2210
220	10 × 16	0.050	1650				12.5 × 20	0.062	1750	12.5 × 20	0.070	1750	12.5 × 30	0.042	2400
270							12.5 × 20	0.062	1750	12.5 × 25	0.047	2210	16 × 20	0.048	1950
330	10 × 20	0.036	2060	10 × 20	0.070	1570	12.5 × 25	0.047	2210	12.5 × 25	0.060	2210	16 × 25	0.038	2430
390	12.5 × 20	0.030	2240	12.5 × 20	0.060	1990	12.5 × 30	0.042	2400	12.5 × 30	0.040	2400	16 × 31.5	0.032	2640
470	12.5 × 20	0.030	2300	12.5 × 25	0.039	2460	16 × 20	0.048	1950	16 × 20	0.046	1950	18 × 25	0.036	2500
560															
680	12.5 × 25	0.024	2800				12.5 × 40	0.032	2860	12.5 × 40	0.030	2860	16 × 25	0.036	2430
820	12.5 × 30	0.022	3370	16 × 25	0.025	2890	16 × 25	0.038	2430	16 × 25	0.036	2430	18 × 20	0.045	2270
1000	16 × 25	0.021	3510	16 × 31.5	0.023	2950	18 × 20	0.045	2270	18 × 25	0.034	2500	18 × 31.5	0.030	2860
1200															
2200				18 × 40	0.020	3200									

# MINIATURE ALUMINUM ELECTROLYTIC CAPACITORS



## LN Low Imp., High Ripple Current Series

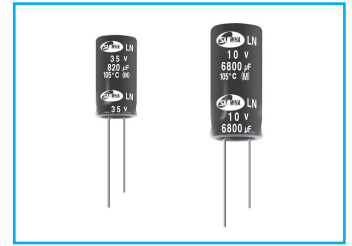

- Higher ripple current compared with LQ series
- Enabled high ripple current by a reduction of impedance at high frequency range
- High reliability withstanding 10000 hours load life at 105°C
- Complied to the RoHS directive



Item	Characteristics									
Operating temperature range	-40 ~ +105°C									
Leakage current max.	I = 0.01CV or 3µA whichever is greater (after 2 minutes) I = 0.03CV or 4µA whichever is greater (after 1 minute)									
Capacitance tolerance	±20% at 120Hz, 20°C									
Dissipation factor max. (at 120Hz, 20°C)	Capacitance > 1000µF : tanδ increases by 0.02 for each 1000µF from below value.									
	<table border="1"> <tr> <td>WV</td> <td>10</td> <td>16</td> <td>25</td> <td>35</td> </tr> <tr> <td>tanδ</td> <td>0.18</td> <td>0.15</td> <td>0.13</td> <td>0.11</td> </tr> </table>	WV	10	16	25	35	tanδ	0.18	0.15	0.13
WV	10	16	25	35						
tanδ	0.18	0.15	0.13	0.11						
Low temperature characteristics (Impedance ratio at 120Hz)	Z-40°C / Z+20°C									
	<table border="1"> <tr> <td>Z-40°C / Z+20°C</td> <td>3</td> <td>Z-25°C / Z+20°C</td> <td>2</td> </tr> </table>	Z-40°C / Z+20°C	3	Z-25°C / Z+20°C	2					
Z-40°C / Z+20°C	3	Z-25°C / Z+20°C	2							
Load life	After an application of DC bias voltage plus the rated AC ripple current for 10000 hours at 105°C. The measurement shall meet the following limits. The DC voltage plus the peak AC voltage combined must not exceed the rated voltage.									
	Leakage current	Less than specified value								
	Capacitance change	Within ±25% of initial value								
	tanδ	Less than 200% of specified value								
Shelf life (at 105°C)	After 1000 hours no load test, leakage current, capacitance and tanδ are same as load life value. The measurement shall be performed at 20°C by the KS C IEC 60384 - 4									

### DRAWING

Unit : mm

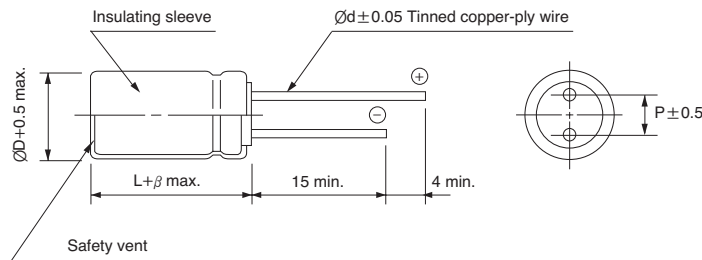

ØD	10	12.5	16
P	5.0	5.0	7.5
Ød	0.6	0.6	0.8
β	2.0		

### FREQUENCY COEFFICIENT OF PERMISSIBLE RIPPLE CURRENT

µF \ Frequency	120Hz	1kHz	10kHz	50kHz	100kHz ≤
~ 560	0.50	0.85	0.95	0.98	1.00
680 ~ 1800	0.60	0.87	0.95	0.98	1.00
2200 ~ 3900	0.75	0.90	0.95	0.98	1.00
4700 ~ 12000	0.85	0.95	0.98	0.99	1.00

# MINIATURE ALUMINUM ELECTROLYTIC CAPACITORS

**LN** series

● DIMENSIONS & MAXIMUM PERMISSIBLE RIPPLE CURRENT

WV Item $\mu\text{F}$	10			16		
	$\varnothing\text{D} \times \text{L}$ (mm)	Impedance ( $\Omega$ )max. 20°C 100kHz	Ripple current (mA rms) 105°C 100kHz	$\varnothing\text{D} \times \text{L}$ (mm)	Impedance ( $\Omega$ )max. 20°C 100kHz	Ripple current (mA rms) 105°C 100kHz
820				10 × 16	0.032	2000
1000				10 × 16	0.032	2000
1200	10 × 16	0.032	2000	10 × 20	0.024	2500
1500	10 × 16	0.032	2000	10 × 20	0.024	2500
1800	10 × 20	0.024	2500	12.5 × 20	0.020	2600
2200	12.5 × 20	0.020	2600	12.5 × 20	0.020	2900
3300	12.5 × 20	0.020	2900	12.5 × 25	0.017	3200
3900	12.5 × 25	0.017	3200	16 × 20	0.017	3575
4700	16 × 20	0.017	3575	16 × 25	0.015	3810
5600	16 × 25	0.015	3810	16 × 25	0.015	3810
6800	16 × 25	0.015	3810	16 × 31.5	0.012	4000
8200	16 × 31.5	0.012	4000	16 × 35.5	0.011	4200
10000	16 × 31.5	0.012	4000			
12000	16 × 35.5	0.011	4200			

WV Item $\mu\text{F}$	25			35		
	$\varnothing\text{D} \times \text{L}$ (mm)	Impedance ( $\Omega$ )max. 20°C 100kHz	Ripple current (mA rms) 105°C 100kHz	$\varnothing\text{D} \times \text{L}$ (mm)	Impedance ( $\Omega$ )max. 20°C 100kHz	Ripple current (mA rms) 105°C 100kHz
390				10 × 16	0.032	2000
470				10 × 16	0.032	2000
560				10 × 20	0.024	2500
680	10 × 16	0.032	2000	12.5 × 20	0.020	2600
820	10 × 20	0.024	2500	12.5 × 20	0.020	2600
	10 × 16	0.032	2000	12.5 × 20	0.020	2900
1000	10 × 20	0.024	2500	12.5 × 20	0.020	2600
1200	12.5 × 20	0.020	2600	12.5 × 25	0.017	3200
1500	12.5 × 20	0.020	2900	16 × 20	0.017	3575
1800	12.5 × 25	0.017	3200	16 × 25	0.015	3600
2200	12.5 × 25	0.017	3200	16 × 25	0.015	3700
2200	16 × 20	0.017	3575			
3300	16 × 25	0.015	3810	16 × 31.5	0.013	3800
3900	16 × 25	0.014	3810	16 × 35.5	0.012	4000
4700	16 × 31.5	0.014	4000			
5600	16 × 35.5	0.013	4200			

# MINIATURE ALUMINUM ELECTROLYTIC CAPACITORS



## LY Miniature, Long Life, For LED Lighting Series

- Miniature, long life
- For LED Lighting
- High reliability withstanding 10000 hours load life at 105°C
- Complied to the RoHS directive

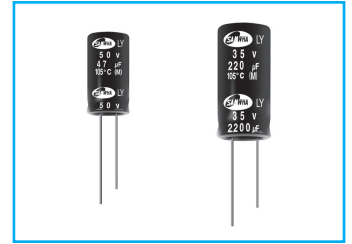

Item	Characteristics																								
Operating temperature range	-40 ~ +105°C																								
Leakage current max.	I = 0.01CV or 3μA whichever is greater (after 2 minutes) I = 0.03CV or 4μA whichever is greater (after 1 minute)																								
Capacitance tolerance	±20% at 120Hz, 20°C																								
Dissipation factor max. (at 120Hz, 20°C)	<table border="1"> <tr> <td>WV</td> <td>10</td> <td>16</td> <td>25</td> <td>35</td> <td>50</td> <td>63</td> <td>100</td> </tr> <tr> <td>tanδ</td> <td>0.45</td> <td>0.35</td> <td>0.30</td> <td>0.22</td> <td>0.19</td> <td>0.17</td> <td>0.15</td> </tr> </table>	WV	10	16	25	35	50	63	100	tanδ	0.45	0.35	0.30	0.22	0.19	0.17	0.15								
	WV	10	16	25	35	50	63	100																	
tanδ	0.45	0.35	0.30	0.22	0.19	0.17	0.15																		
Low temperature characteristics (Impedance ratio at 120Hz)	<table border="1"> <tr> <td>WV</td> <td>10</td> <td>16</td> <td>25</td> <td>35</td> <td>50</td> <td>63</td> <td>100</td> </tr> <tr> <td>Z-25°C/Z+20°C</td> <td>3</td> <td>2</td> <td>2</td> <td>2</td> <td>2</td> <td>2</td> <td>2</td> </tr> <tr> <td>Z-40°C/Z+20°C</td> <td>8</td> <td>6</td> <td>3</td> <td>3</td> <td>4</td> <td>4</td> <td>4</td> </tr> </table>	WV	10	16	25	35	50	63	100	Z-25°C/Z+20°C	3	2	2	2	2	2	2	Z-40°C/Z+20°C	8	6	3	3	4	4	4
	WV	10	16	25	35	50	63	100																	
	Z-25°C/Z+20°C	3	2	2	2	2	2	2																	
Z-40°C/Z+20°C	8	6	3	3	4	4	4																		
Load life (after application of the rated voltage for 10000 hours at 105°C)	Leakage current	Less than specified value																							
	Capacitance change	Within ±25% of the initial value																							
	tanδ	Less than 200% of the specified value																							
Shelf life (at 105°C)	After 1000 hours no load test, leakage current, capacitance and tanδ are same as load life value. The measurement shall be performed at 20°C by the KS C IEC 60384 - 4																								

### DRAWING

Unit : mm

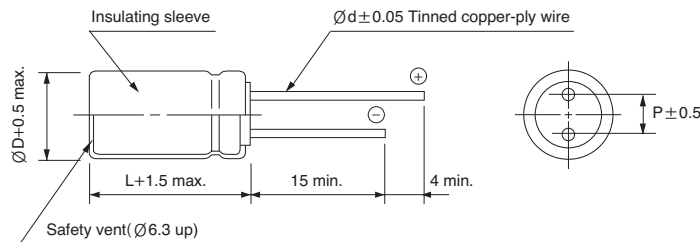

ØD	5	6.3	8
P	2.0	2.5	3.5
Ød	0.5	0.5	0.6

### FREQUENCY COEFFICIENT OF PERMISSIBLE RIPPLE CURRENT

Frequency	120Hz	1kHz	10kHz	50kHz	100kHz ≤
~ 33	0.42	0.70	0.90	0.95	1.00
47 ~	0.55	0.73	0.92	0.96	1.00

# MINIATURE ALUMINUM ELECTROLYTIC CAPACITORS

**LY** series

● DIMENSIONS & MAXIMUM PERMISSIBLE RIPPLE CURRENT

WV Item μF	10			16			25		
	∅D×L (mm)	Impedance (Ω)max. 20°C 100kHz	Ripple current (mA rms) 105°C 100kHz	∅D×L (mm)	Impedance (Ω)max. 20°C 100kHz	Ripple current (mA rms) 105°C 100kHz	∅D×L (mm)	Impedance (Ω)max. 20°C 100kHz	Ripple current (mA rms) 105°C 100kHz
33							5×11	1.50	172
47				5×11	1.20	193	5×11	0.60	193
100	5×11	0.60	193	6.3×11	0.60	277	6.3×11	0.45	277
220	6.3×11	0.50	277	8×11.5	0.45	436	8×11.5	0.20	436
330	8×11.5	0.40	436	8×11.5	0.40	436			

WV Item μF	35			50			63		
	∅D×L (mm)	Impedance (Ω)max. 20°C 100kHz	Ripple current (mA rms) 105°C 100kHz	∅D×L (mm)	Impedance (Ω)max. 20°C 100kHz	Ripple current (mA rms) 105°C 100kHz	∅D×L (mm)	Impedance (Ω)max. 20°C 100kHz	Ripple current (mA rms) 105°C 100kHz
1.0				5×11	3.50	35			
2.2				5×11	2.50	46			
3.3				5×11	2.00	92			
4.7				5×11	2.00	106			
10				5×11	1.60	119			
22				5×11	1.60	145	6.3×11	1.20	265
33	5×11	0.60	193	6.3×11	1.50	251	6.3×11	1.20	265
47	6.3×11	0.50	277	6.3×11	0.70	251	8×11.5	0.30	270
100	8×11.5	0.35	436	8×11.5	0.45	356			
220	8×15	0.30	473						

WV Item μF	100		
	∅D×L (mm)	Impedance (Ω)max. 20°C 100kHz	Ripple current (mA rms) 105°C 100kHz
33	8×11.5	1.20	264
47	8×11.5	1.20	264
100	8×11.5	0.30	264

# MINIATURE ALUMINUM ELECTROLYTIC CAPACITORS



## MH Low Imp., Long Life Series

Low Impedance   
 Miniaturized   
 Solvent Proof

- Long Life compared with ML series
- High reliability withstanding 12000 hours load life at 105°C (7000/9000 hours for as specified below)
- Complied to the RoHS directive

ML  $\rightarrow$  MH  
 Long life

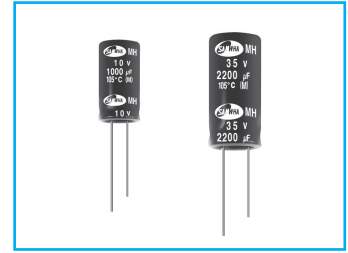

Item	Characteristics													
Operating temperature range	-40 ~ +105°C													
Leakage current max.	I = 0.01CV or 3µA whichever is greater (after 2 minutes) I = 0.03CV or 4µA whichever is greater (after 1 minute)													
Capacitance tolerance	±20% at 120Hz, 20°C													
Dissipation factor max. (at 120Hz, 20°C)	Capacitance > 1000µF : tanδ increases by 0.02 for each 1000µF from below value.													
	<table border="1"> <thead> <tr> <th>WV</th> <th>6.3</th> <th>10</th> <th>16</th> <th>25</th> <th>35</th> <th>50</th> </tr> </thead> <tbody> <tr> <td>tanδ</td> <td>0.22</td> <td>0.19</td> <td>0.16</td> <td>0.14</td> <td>0.12</td> <td>0.10</td> </tr> </tbody> </table>	WV	6.3	10	16	25	35	50	tanδ	0.22	0.19	0.16	0.14	0.12
WV	6.3	10	16	25	35	50								
tanδ	0.22	0.19	0.16	0.14	0.12	0.10								
Low temperature characteristics (Impedance ratio at 120Hz)	Z-40°C / Z+20°C													
	Z-25°C / Z+20°C													
Load life	After an application of DC bias voltage plus the rated AC ripple current for 12000 hours at 105°C. The measurement shall meet the following limits. The DC voltage plus the peak AC voltage combined must not exceed the rated voltage.													
	<table border="1"> <tbody> <tr> <td>Leakage current</td> <td>Less than specified value</td> </tr> <tr> <td>Capacitance change</td> <td>Within ±25% of initial value</td> </tr> <tr> <td>tanδ</td> <td>Less than 200% of specified value</td> </tr> </tbody> </table>	Leakage current	Less than specified value	Capacitance change	Within ±25% of initial value	tanδ	Less than 200% of specified value							
	Leakage current	Less than specified value												
	Capacitance change	Within ±25% of initial value												
tanδ	Less than 200% of specified value													
<table border="1"> <thead> <tr> <th>∅D</th> <th>∅D = 5, 6.3</th> <th>∅D = 8</th> <th>∅D ≥ 10</th> </tr> </thead> <tbody> <tr> <td>Life time</td> <td>7000 hours</td> <td>9000 hours</td> <td>12000 hours</td> </tr> </tbody> </table>	∅D	∅D = 5, 6.3	∅D = 8	∅D ≥ 10	Life time	7000 hours	9000 hours	12000 hours						
∅D	∅D = 5, 6.3	∅D = 8	∅D ≥ 10											
Life time	7000 hours	9000 hours	12000 hours											
Shelf life (at 105°C)	After 1000 hours no load test, leakage current, capacitance and tanδ are same as load life value. The measurement shall be performed at 20°C by the KS C IEC 60384 - 4													

### DRAWING

Unit : mm

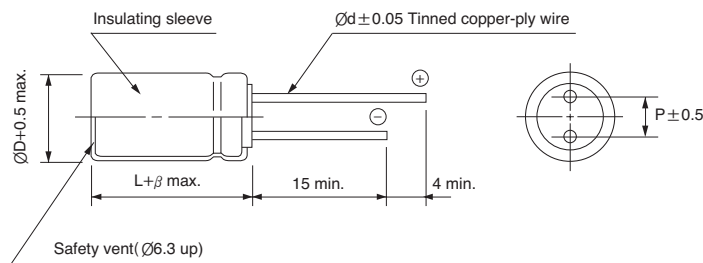

∅D	5	6.3	8	10	12.5	16	18
P	2.0	2.5	3.5	5.0	5.0	7.5	7.5
∅d	0.5	0.5	0.6	0.6	0.6	0.8	0.8
β	1.5			2.0			

### FREQUENCY COEFFICIENT OF PERMISSIBLE RIPPLE CURRENT

µF \ Frequency	120Hz	1kHz	10kHz	50kHz	100kHz ≤
~ 33	0.42	0.70	0.90	0.95	1.00
47 ~ 220	0.50	0.73	0.92	0.96	1.00
330 ~ 680	0.55	0.77	0.94	0.97	1.00
1000 ~ 1500	0.60	0.80	0.96	0.98	1.00
2200 ~	0.70	0.85	0.98	0.99	1.00



# MINIATURE ALUMINUM ELECTROLYTIC CAPACITORS

**MH** series

● DIMENSIONS & MAXIMUM PERMISSIBLE RIPPLE CURRENT

WV Item μF	6.3			10			16		
	∅D×L (mm)	Impedance (Ω)max. 20°C 100kHz	Ripple current (mA rms) 105°C 100kHz	∅D×L (mm)	Impedance (Ω)max. 20°C 100kHz	Ripple current (mA rms) 105°C 100kHz	∅D×L (mm)	Impedance (Ω)max. 20°C 100kHz	Ripple current (mA rms) 105°C 100kHz
10							5 × 11	0.35	250
22	5 × 11	0.35	250	5 × 11	0.35	250	5 × 11	0.35	250
33	5 × 11	0.35	250	5 × 11	0.35	250	5 × 11	0.35	250
47	5 × 11	0.30	250	5 × 11	0.30	250	5 × 11	0.30	250
100	5 × 11	0.30	250	5 × 11	0.30	250	6.3 × 11	0.25	405
150	6.3 × 11	0.15	405	6.3 × 11	0.15	405	6.3 × 11	0.20	405
220	6.3 × 11	0.15	405	6.3 × 11	0.15	405	8 × 11.5	0.15	760
330	6.3 × 11	0.15	405	8 × 11.5	0.13	760	8 × 11.5	0.10	760
390	6.3 × 11	0.15	405	8 × 11.5	0.11	760	8 × 11.5	0.10	760
470	8 × 11.5	0.11	630	8 × 11.5	0.11	760	10 × 12.5	0.053	1030
560	8 × 11.5	0.11	760	10 × 12.5	0.053	760	10 × 12.5	0.053	1100
680	10 × 12.5	0.053	1030	10 × 12.5	0.053	1030	10 × 16	0.038	1430
1000	10 × 12.5	0.053	1030	10 × 12.5	0.053	1330	10 × 16	0.038	1760
1500	10 × 20	0.027	1820	10 × 20	0.030	1820	10 × 20	0.030	1960
2200	12.5 × 20	0.025	2360	12.5 × 20	0.027	2360	12.5 × 25	0.023	2770
3300	12.5 × 20	0.025	2360	12.5 × 20	0.027	2480	16 × 20	0.020	3250
4700	16 × 25	0.015	3460	16 × 25	0.022	3250	16 × 25	0.018	3630
6800	16 × 25	0.015	3460	16 × 25	0.018	3630			
10000	16 × 31.5	0.015	3680	18 × 31.5	0.015	3700			

WV Item μF	25			35			50		
	∅D×L (mm)	Impedance (Ω)max. 20°C 100kHz	Ripple current (mA rms) 105°C 100kHz	∅D×L (mm)	Impedance (Ω)max. 20°C 100kHz	Ripple current (mA rms) 105°C 100kHz	∅D×L (mm)	Impedance (Ω)max. 20°C 100kHz	Ripple current (mA rms) 105°C 100kHz
10	5 × 11	0.35	250	5 × 11	0.55	250	5 × 11	0.60	250
22	5 × 11	0.35	250	5 × 11	0.50	250	5 × 11	0.45	250
33	5 × 11	0.35	250	5 × 11	0.45	250	6.3 × 11	0.25	405
47	5 × 11	0.30	250	6.3 × 11	0.30	405	6.3 × 11	0.20	405
56	6.3 × 11	0.27	405	6.3 × 11	0.20	405	6.3 × 11	0.20	405
68	6.3 × 11	0.27	405	8 × 11.5	0.10	540	8 × 11.5	0.15	540
100	6.3 × 11	0.20	405	8 × 11.5	0.10	760	8 × 11.5	0.12	760
150	8 × 11.5	0.14	760	8 × 11.5	0.10	760	10 × 12.5	0.061	1030
220	8 × 11.5	0.12	760	10 × 12.5	0.053	1030	10 × 16	0.038	1430
330	10 × 12.5	0.053	1030	10 × 12.5	0.053	1330	10 × 20	0.032	1820
390	10 × 12.5	0.053	1250	10 × 16	0.048	1550	12.5 × 20	0.031	2000
470	10 × 12.5	0.050	1330	10 × 16	0.041	1760	12.5 × 20	0.030	2360
560	10 × 16	0.050	1800	10 × 20	0.037	2100	12.5 × 25	0.027	2450
680	10 × 16	0.040	1760	12.5 × 20	0.026	2360	12.5 × 25	0.022	2770
1000	10 × 20	0.033	1960	12.5 × 20	0.026	2480	16 × 25	0.018	3460
1500	12.5 × 20	0.029	2550	16 × 20	0.022	3250	16 × 31.5	0.015	3680
2200	16 × 20	0.022	3250	16 × 25	0.018	3630			
3300	16 × 25	0.018	3630						

## QY Long Life Series

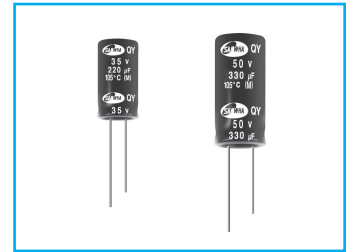

- High reliability withstanding 13000 hours load life at 105°C
- Complied to the RoHS directive, Halogen-Free

Item	Characteristics		
Operating temperature range	-25 ~ +105°C		
Leakage current max.	I = 0.01CV or 3µA (after 2 minutes)		
Capacitance tolerance	±20% at 120Hz, 20°C		
Dissipation factor max. (at 120Hz, 20°C)	WV	35	50
	tanδ	0.22	0.19
Low temperature characteristics (Impedance ratio at 120Hz)	WV	35	50
	Z-25°C/Z+20°C	3	3
Load life (after application of the rated voltage for 13000 hours at 105°C)	Leakage current	Less than specified value	
	Capacitance change	Within ±30% of initial value	
	tanδ	Less than 300% of specified value	
Shelf life (at 105°C)	After 1000 hours no load test, leakage current, capacitance and tanδ are same as load life value. The measurement shall be performed at 20°C by the KS C IEC 60384 - 4		

### DRAWING

Unit : mm

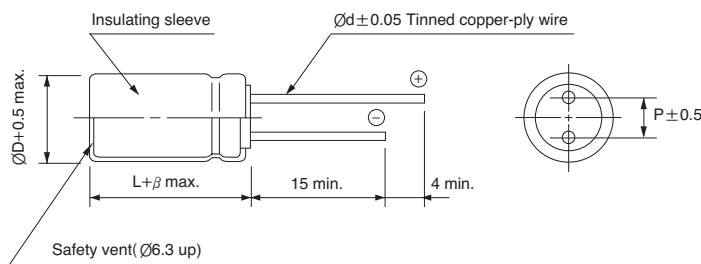

ØD	6.3	8	10	12.5
L	-	7	11.5	-
P	2.5	3.5	3.5	5.0
Ød	0.5	0.5	0.6	0.6
β	1.5		2.0	

### DIMENSIONS & MAXIMUM PERMISSIBLE RIPPLE CURRENT

µF \ WV	35		50	
22			6.3 × 11	228
47	6.3 × 11	205	6.3 × 11	228
			8 × 7	228
100	8 × 11.5	550	8 × 11.5	450
			10 × 16	700
220	10 × 16	800	12.5 × 20	990
330	10 × 20	1030	12.5 × 25	1250
470	12.5 × 20	1320	12.5 × 30	1585
560	12.5 × 25	1500		

↑ Ripple current (mA rms) at 105°C, 100kHz  
 ↑ Case size ØD × L (mm)

### FREQUENCY COEFFICIENT OF PERMISSIBLE RIPPLE CURRENT

µF \ Frequency	120Hz	1kHz	10kHz	50kHz	100kHz ≤
~ 22	0.25	0.50	0.75	0.90	1.00
47 ~	0.30	0.55	0.80	0.90	1.00

# MINIATURE ALUMINUM ELECTROLYTIC CAPACITORS

**MG** Long Life Series

- Long Life
- For LED Lighting
- High reliability withstanding 20000 hours load life at 105°C
- Complied to the RoHS directive

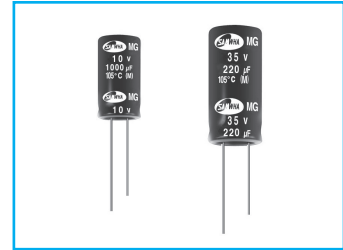

Item	Characteristics				
Operating temperature range	-40 ~ +105°C				
Leakage current max.	I = 0.03CV or 4μA whichever is greater (after 1 minutes)				
Capacitance tolerance	±20% at 120Hz, 20°C				
Dissipation factor max. (at 120Hz, 20°C)	WV	10	16	25	35
	tanδ	0.20	0.16	0.14	0.12
Low temperature characteristics (Impedance ratio at 120Hz)	WV	10	16	25	35
	Z-25°C/Z+20°C	3	2	2	2
	Z-40°C/Z+20°C	3	3	3	3
Load life (after application of the rated voltage for 20000 hours at 105°C)	Leakage current	Less than specified value			
	Capacitance change	Within ±30% of initial value			
	tanδ	Less than 300% of specified value			
Shelf life (at 105°C)	After 1000 hours no load test, leakage current, capacitance and tanδ are same as load life value. The measurement shall be performed at 20°C by the KS C IEC 60384 - 4				

## ● DRAWING

Unit : mm

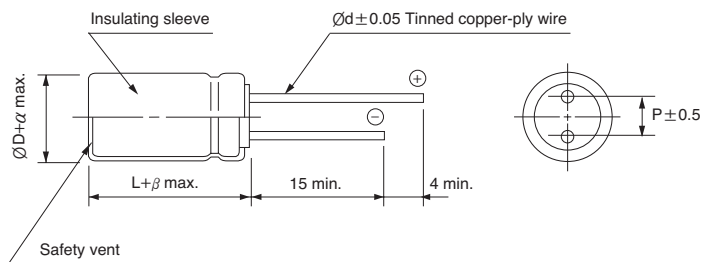

ØD	10	12.5	16	18
P	5.0	5.0	7.5	7.5
Ød	0.6	0.6	0.8	0.8
α	0.5			
β	2.0			

## ● DIMENSIONS & MAXIMUM PERMISSIBLE RIPPLE CURRENT

μF \ WV	10		16		25		35	
100					10 × 12.5	420	10 × 16	672
220			10 × 12.5	504	10 × 12.5	840	10 × 20	1008
330	10 × 12.5	504	10 × 16	672	10 × 16	1008	12.5 × 20	1344
470	10 × 12.5	672	10 × 20	806	10 × 20	1344	12.5 × 20	1680
680	10 × 16	806	12.5 × 20	1008	12.5 × 20	1008	12.5 × 25	1879
1000	10 × 20	1008	12.5 × 25	1680	12.5 × 25	1680	16 × 25	2184
2200	12.5 × 25	1680	16 × 25	2016				
3300	16 × 25	2016	16 × 31.5	2184				
4700	16 × 31.5	2184						

↑ ↑  
Ripple current (mA rms) at 105°C, 100kHz  
Case size ØD × L (mm)

## ● FREQUENCY COEFFICIENT OF PERMISSIBLE RIPPLE CURRENT

Frequency	120Hz	1kHz	10kHz	50kHz	100kHz ≤
Coefficient	0.75	0.8	0.9	0.95	1.00

# MINIATURE ALUMINUM ELECTROLYTIC CAPACITORS



## KS For PSU, Long Life Series

- High reliability withstanding 8000 hours load life at 85°C
- Suitable for CFL, adapter and power supply
- Complied to the RoHS directive

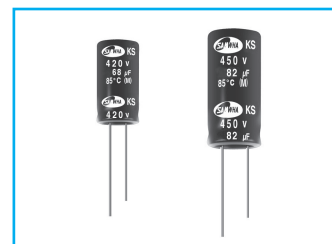

Item	Characteristics			
Operating temperature range	-25 ~ +85°C			
Leakage current max.	$I = 0.02CV + 25\mu A$ (after 5 minutes)			
Capacitance tolerance	±20% at 120Hz, 20°C			
Dissipation factor max. (at 120Hz, 20°C)	WV	420	450	500
	tanδ	0.2	0.2	0.2
Low temperature characteristics (Impedance ratio at 120Hz)	WV	420	450	500
	Z(-25°C) / Z(+20°C)	6	6	6
Load life (after application of the rated voltage for 8000 hours at 85°C)	Leakage current	Less than specified value		
	Capacitance change	Within ±20% of initial value		
	tanδ	Less than 200% of specified value		
Shelf life (at 85°C)	After 1000 hours no load test, leakage current, capacitance and tanδ are same as load life value. The measurement shall be performed at 20°C by the KS C IEC 60384 - 4			

### DRAWING

Unit : mm

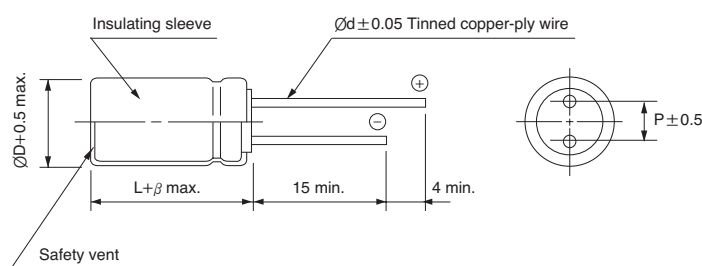

ØD	16	18	20
P	7.5	7.5	10.0
Ød	0.8	0.8	0.8
β	L ≤ 40mm	2.0	-
	L > 40mm	3.0	-

### DIMENSIONS & MAXIMUM PERMISSIBLE RIPPLE CURRENT

µF	WV	420		450		500	
		47					16 × 35.5
56						16 × 40	552
68	16 × 31.5	726	16 × 35.5	738	16 × 40	648	
			18 × 31.5	738	18 × 40		
82	16 × 40	768	16 × 40	834	16 × 40	684	
			18 × 31.5	834			
100	16 × 40	960	16 × 45	990	16 × 50	924	
			18 × 35.5	990			
120	16 × 45	1122	16 × 50	1056	20 × 41	1035	
150			18 × 45	1146			

Ripple current (mA rms) at 85°C, 120Hz  
Case size ØD × L (mm)

### FREQUENCY COEFFICIENT OF PERMISSIBLE RIPPLE CURRENT

WV	Frequency	120Hz	1kHz	10kHz	50kHz, 100kHz
420 ~ 500V		1.00	1.40	1.50	2.00

MINIATURE TYPES

# MINIATURE ALUMINUM ELECTROLYTIC CAPACITORS



High Ripple Current, Long Life Series

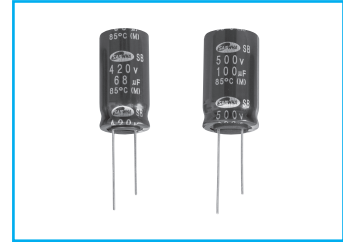

- High reliability withstanding 10000 hours load life at 85°C
- Suitable for CFL, adapter and power supply
- Complied to the RoHS directive

Item	Characteristics			
Operating temperature range	-25 ~ +85°C			
Leakage current max.	$I = 0.02CV + 25\mu A$ (after 5 minutes)			
Capacitance tolerance	±20% at 120Hz, 20°C			
Dissipation factor max. (at 120Hz, 20°C)	WV	420	450	500
	tanδ	0.20	0.20	0.20
Low temperature characteristics (Impedance ratio at 120Hz)	WV	420	450	500
	$Z(-25^\circ C) / Z(+20^\circ C)$	6	6	6
Load life (after application of the rated voltage for 10000 hours at 85°C)	Leakage current	Less than specified value		
	Capacitance change	Within ±20% of initial value		
	tanδ	Less than 200% of specified value		
Shelf life (at 85°C)	After 1000 hours no load test, leakage current, capacitance and tanδ are same as load life value. The measurement shall be performed at 20°C by the KS C IEC 60384 - 4			

## ● DRAWING

Unit : mm

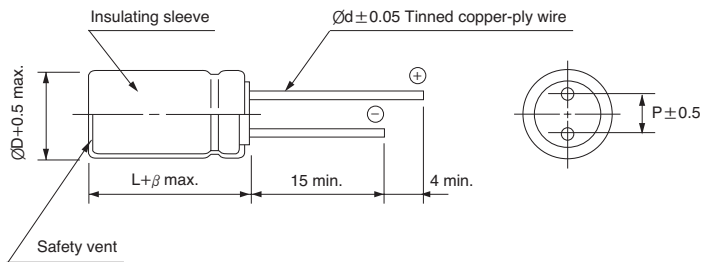

ØD	16	18
P	7.5	7.5
Ød	0.8	0.8
β	L ≤ 40mm	2.0
	L > 40mm	3.0

## ● DIMENSIONS & MAXIMUM PERMISSIBLE RIPPLE CURRENT

µF \ WV	420		450		500	
47					16 × 35.5	430
56					16 × 40	500
68	16 × 31.5	660	16 × 35.5	760	16 × 45	590
			18 × 31.5		18 × 40	
82	16 × 31.5	700	16 × 40	900	16 × 50	620
			18 × 31.5			
100	16 × 40	870	16 × 40	920	16 × 50	900
			18 × 35.5			
120	16 × 45	1020	16 × 50	960		
150			16 × 50	1040		

↑ Ripple current (mA rms) at 85°C, 120Hz  
 ↑ Case size ØD × L (mm)

## ● FREQUENCY COEFFICIENT OF PERMISSIBLE RIPPLE CURRENT

WV \ Frequency	120Hz	1kHz	10kHz	50kHz, 100kHz
420 ~ 500V	1.00	1.40	1.50	2.00

# MINIATURE ALUMINUM ELECTROLYTIC CAPACITORS



## KA For PSU, High Ripple Current Series

- High ripple current
- Operating temperature range of -40 ~ +105°C
- Complied to the RoHS directive

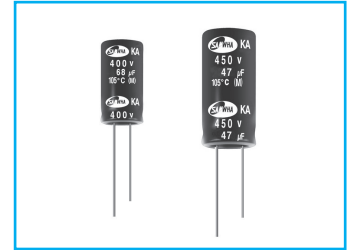

Item	Characteristics		
Operating temperature range	WV	400 ~ 450	500
	Temperature range	-40 ~ +105°C	-25 ~ +105°C
Leakage current max.	I = 0.02CV + 15μA (after 5 minutes)		
Capacitance tolerance	±20% at 120Hz, 20°C		
Dissipation factor max.	0.2max. at 120Hz, 20°C		
Low temperature characteristics (Impedance ratio at 120Hz)	WV	400 ~ 450	500
	Z-25°C/Z+20°C	6	8
	Z-40°C/Z+20°C	10	-
Load life	After an application of DC bias voltage plus the rated AC ripple current for 3000 hours at 105°C. The measurement shall meet the following limits. The DC voltage plus the peak AC voltage combined must not exceed the rated voltage.		
	Leakage current	Less than specified value	
	Capacitance change	Within ±20% of initial value	
Shelf life (at 105°C)	After 1000 hours no load test, leakage current, capacitance and tanδ are same as load life value. The measurement shall be performed at 20°C by the KS C IEC 60384 - 4		
	tanδ		
		Less than 200% of specified value	

### DRAWING

Unit : mm

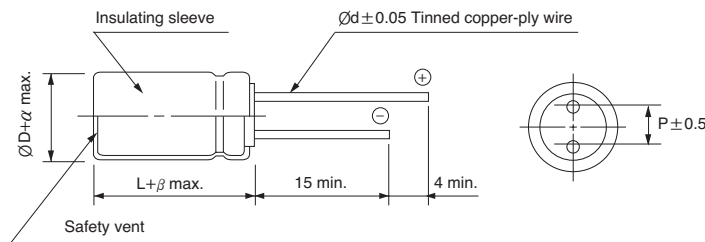

ØD	10	12.5	16	18	20
P	5.0	5.0	7.5	7.5	10.0
Ød	0.6	0.6	0.8	0.8	0.8
α	0.5				1.0
β	2.0				3.0

### FREQUENCY COEFFICIENT OF PERMISSIBLE RIPPLE CURRENT

µF \ Frequency	120Hz	1kHz	10kHz	50kHz	100kHz ≤
~ 33	0.40	0.65	0.82	0.91	1.00
47 ~ 150	0.50	0.70	0.84	0.92	1.00

# MINIATURE ALUMINUM ELECTROLYTIC CAPACITORS

**KA** series

● DIMENSIONS & MAXIMUM PERMISSIBLE RIPPLE CURRENT

WV Item μF	400		420		450		500	
	ØD×L(mm)	Ripple current (mA rms) 105°C, 100kHz	ØD×L(mm)	Ripple current (mA rms) 105°C, 100kHz	ØD×L(mm)	Ripple current (mA rms) 105°C, 100kHz	ØD×L(mm)	Ripple current (mA rms) 105°C, 100kHz
3.3					10×20	150		
4.7					10×20	200		
10	10×16	176			10×20	230	12.5×20	240
	10×20	180						
22	12.5×25	300			12.5×25	525	12.5×30	420
							16×25	470
33	16×20	600			16×25	600	18×25	580
47	16×25	700	16×25	630	16×25	660	16×35.5	650
					16×31.5	720	18×31.5	650
					18×25	720	18×35.5	700
56			16×31.5	740	16×31.5	800	16×40	740
			18×25		18×25	800		
68	16×31.5	1100	16×31.5	810	16×31.5	900	16×45	820
							18×40	900
82	16×35.5	1150	16×40	960	16×40	1115	16×50	1000
			18×31.5	960	18×31.5	1115	18×40	1000
100	18×35.5	1200	16×40	1100			16×50	1250
			18×35.5	1100	16×40	1500	18×45	1250
					18×35.5	1500	20×41	1250
120	18×40	1270	16×50	1250	16×50	1500	20×41	1370
			18×40	1250	18×40	1500		
150	20×41	1380			20×41	1600		

## RH For PSU High Ripple Current, Long Life Series

- High ripple current
- High reliability withstanding 5000 hours load life at 105°C
- Suited for ballast application
- Complied to the RoHS directive

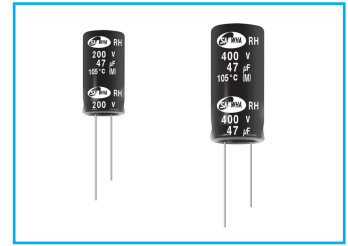
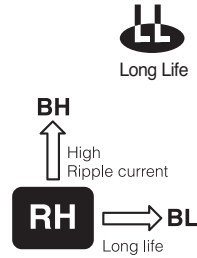

Item	Characteristics									
Operating temperature range	WV	160 ~ 450							500	
	Temperature range	-40 ~ +105°C							-25 ~ +105°C	
Leakage current max.	I = 0.02CV + 15µA (after 5 minutes)									
Capacitance tolerance	±20% at 120Hz, 20°C									
Dissipation factor max. (at 120Hz, 20°C)	WV	160	200	250	350	400	420	450	500	
	tanδ	0.15	0.15	0.15	0.20	0.24	0.24	0.24	0.24	
Low temperature characteristics (Impedance ratio at 120Hz)	WV	160	200	250	350	400	450	500		
	Z-25°C/Z+20°C	3	3	3	4	6	6	6		
	Z-40°C/Z+20°C	4	4	4	8	10	10	-		
Load life	After an application of DC bias voltage plus the rated AC ripple current for 5000 hours at 105°C. The measurement shall meet the following limits. The DC voltage plus the peak AC voltage combined must not exceed the rated voltage.									
	Leakage current	Less than specified value								
	Capacitance change	Within ±20% of initial value								
	tanδ	Less than 200% of specified value								
Shelf life (at 105°C)	After 1000 hours no load test, leakage current, capacitance and tanδ are same as load life value. The measurement shall be performed at 20°C by the KS C IEC 60384 - 4									

### ● DRAWING

Unit : mm

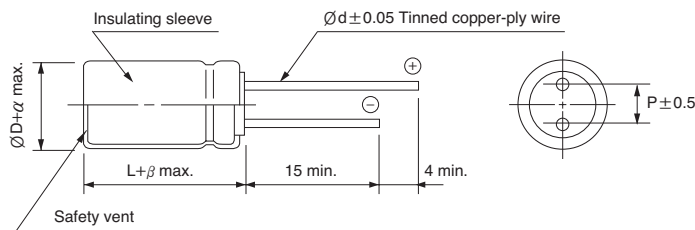

ØD	10	12.5	16	18	20	22
P	5.0	5.0	7.5	7.5	10.0	10.0
Ød	0.6	0.6	0.8	0.8	0.8	1.0
α	0.5				1.0	
β	2.0				3.0	

### ● FREQUENCY COEFFICIENT OF PERMISSIBLE RIPPLE CURRENT

µF	Frequency	60Hz	120Hz	1kHz	10kHz	50kHz	100kHz ≤
~ 4.7		0.25	0.30	0.60	0.80	0.90	1.00
6.8 ~ 15		0.30	0.40	0.70	0.90	0.95	1.00
22 ~		0.40	0.50	0.80	0.90	0.95	1.00



# MINIATURE ALUMINUM ELECTROLYTIC CAPACITORS

**RH** series

● DIMENSIONS & MAXIMUM PERMISSIBLE RIPPLE CURRENT

$\mu\text{F}$ \diagdown WV	160		200		250		350	
4.7							10 × 16	200
6.8			10 × 12.5	120	10 × 12.5	120	10 × 16	200
10	10 × 16	250	10 × 16	300	10 × 12.5	260	10 × 20	280
15					10 × 12.5	260		
22	10 × 16	360	10 × 16	360	12.5 × 20	600	12.5 × 20	350
	10 × 20	500	10 × 20	500				
33	10 × 20	500	10 × 20	500	12.5 × 20	600	16 × 20	500
			12.5 × 20	600				
47	12.5 × 20	600	12.5 × 20	660	12.5 × 25	720	16 × 25	660
68	12.5 × 25	600	12.5 × 25	760	16 × 25	920	16 × 31.5	800
82	16 × 20	760	16 × 20	880	16 × 25	1120	18 × 31.5	920
100	16 × 25	1100	16 × 25	1120	16 × 31.5	1200	18 × 31.5	1020
120	16 × 25	1180	16 × 31.5	1200	18 × 25	1200	18 × 31.5	1150
150	16 × 31.5	1300	16 × 31.5	1300	18 × 25	1250	18 × 40	1250
					18 × 31.5	1250		
220					18 × 35.5	1600		

$\mu\text{F}$ \diagdown WV	400		420		450		500	
1.0	10 × 12.5	90						
2.2	10 × 12.5	100	10 × 12.5	100	10 × 12.5	100		
3.3	10 × 12.5	128	10 × 12.5	128	10 × 12.5	128		
4.7	10 × 12.5	180	10 × 12.5	180	10 × 16	180		
6.8	10 × 16	200	10 × 16	200	10 × 16	200		
10	10 × 20	280	10 × 20	280	10 × 20	300	12.5 × 20	300
							12.5 × 25	360
15	12.5 × 16	280					12.5 × 25	360
22	12.5 × 25	430	12.5 × 25	430	12.5 × 20	430	16 × 25	420
					16 × 25	550		
33	16 × 25	640	16 × 25	660	16 × 31.5	700	16 × 31.5	560
47	16 × 31.5	750	16 × 31.5	750	16 × 31.5	700	18 × 35.5	700
56			18 × 25	750	18 × 25	750	18 × 35.5	740
68	16 × 31.5	880	16 × 31.5	900	18 × 25	900	18 × 35.5	900
					18 × 31.5	1000		
82	16 × 35.5	1000	16 × 35.5	1000	18 × 31.5	1035	18 × 40	1030
					18 × 35.5	1100		
100	18 × 35.5	1120	18 × 35.5	1170	18 × 35.5	1500	18 × 45	1100
							20 × 41	1200
120	18 × 40	1250	18 × 40	1280	18 × 40	1500		
150	20 × 41	1380	20 × 41	1500	20 × 41	1796		
180	20 × 41	1450	20 × 41	1600	22 × 45	1800		

↑ Ripple current (mA rms) at 105°C, 100kHz  
 ↑ Case size  $\varnothing D \times L$  (mm)

## BH For PSU, High Ripple Current Series

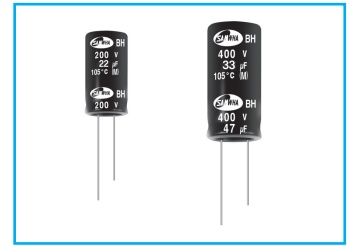

- Higher ripple current compared with RH series
- Operating temperature range of -40 ~ +105°C
- High reliability withstanding 5000 hours load life at 105°C
- Complied to the RoHS directive

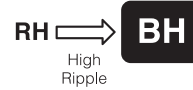

Item	Characteristics																					
Operating temperature range	-40 ~ +105°C																					
Leakage current max.	I = 0.04CV + 100µA (after 1 minute) I = 0.02CV + 25µA (after 5 minutes)																					
Capacitance tolerance	±20% at 120Hz, 20°C																					
Dissipation factor max. (at 120Hz, 20°C)	<table border="1"> <tr> <td>WV</td> <td>200</td> <td>250</td> <td>350</td> <td>400</td> <td>450</td> <td>500</td> </tr> <tr> <td>tanδ</td> <td>0.15</td> <td>0.15</td> <td>0.20</td> <td>0.24</td> <td>0.24</td> <td>0.24</td> </tr> </table>	WV	200	250	350	400	450	500	tanδ	0.15	0.15	0.20	0.24	0.24	0.24							
WV	200	250	350	400	450	500																
tanδ	0.15	0.15	0.20	0.24	0.24	0.24																
Low temperature characteristics (Impedance ratio at 120Hz)	<table border="1"> <tr> <td>WV</td> <td>200</td> <td>250</td> <td>350</td> <td>400</td> <td>450</td> <td>500</td> </tr> <tr> <td>Z-25°C/Z+20°C</td> <td>3</td> <td>3</td> <td>3</td> <td>3</td> <td>3</td> <td>3</td> </tr> <tr> <td>Z-40°C/Z+20°C</td> <td>11</td> <td>11</td> <td>11</td> <td>11</td> <td>11</td> <td>11</td> </tr> </table>	WV	200	250	350	400	450	500	Z-25°C/Z+20°C	3	3	3	3	3	3	Z-40°C/Z+20°C	11	11	11	11	11	11
WV	200	250	350	400	450	500																
Z-25°C/Z+20°C	3	3	3	3	3	3																
Z-40°C/Z+20°C	11	11	11	11	11	11																
Load life	<p>After an application of DC bias voltage plus the rated AC ripple current for 5000 hours at 105°C. The measurement shall meet the following limits. The DC voltage plus the peak AC voltage combined must not exceed the rated voltage.</p> <table border="1"> <tr> <td>Leakage current</td> <td>Less than specified value</td> </tr> <tr> <td>Capacitance change</td> <td>Within ±20% of initial value</td> </tr> <tr> <td>tanδ</td> <td>Less than 200% of specified value</td> </tr> </table>	Leakage current	Less than specified value	Capacitance change	Within ±20% of initial value	tanδ	Less than 200% of specified value															
Leakage current	Less than specified value																					
Capacitance change	Within ±20% of initial value																					
tanδ	Less than 200% of specified value																					
Shelf life (at 105°C)	After 1000 hours no load test, leakage current, capacitance and tanδ are same as load life value. The measurement shall be performed at 20°C by the KS C IEC 60384 - 4																					

● DRAWING (See page 89)

Unit : mm

● DIMENSIONS & MAXIMUM PERMISSIBLE RIPPLE CURRENT

µF \ WV	200		250		350		400	
2.2							10 × 12.5	130
3.3					10 × 12.5	140	10 × 12.5	140
4.7					10 × 16	220	10 × 16	220
6.8					10 × 16	280	10 × 16	280
8.2					8 × 20	300	8 × 20	400
					10 × 16	300	10 × 20	400
10	10 × 16	320	10 × 16	320	8 × 20	300	8 × 23	400
	8 × 20	300	8 × 23	350	10 × 20	400	10 × 20	400
22	10 × 20	550	10 × 20	550	10 × 30	500	12.5 × 20	700
					12.5 × 20	650	12.5 × 25	780
				12.5 × 25	680			
33	12.5 × 20	700	12.5 × 20	800	16 × 25	910	16 × 25	920
47	12.5 × 20	980	12.5 × 25	1040	12.5 × 30	1050		
					18 × 20	1150		
68	12.5 × 20	1100	12.5 × 30	1300	16 × 31.5	1300		
	12.5 × 25	1300	16 × 25	1350				
82	16 × 20	1450	12.5 × 30	1450				
100	12.5 × 30	1550						
	16 × 25	1630						

← Ripple current (mA rms) at 105°C, 100kHz  
Case size ØD×L (mm)

WV	Cap.(µF)	ØD×L(mm)	Rated ripple current (mA rms)105°C				
			120Hz	1kHz	10kHz	50kHz	100kHz≤
450	8.2	8×20	160	280	360	380	400
500	4.7	8×20	70	120	160	216	240
	5.6	8×20	120	210	270	285	300

● FREQUENCY COEFFICIENT OF PERMISSIBLE RIPPLE CURRENT

µF \ Frequency	120Hz	1kHz	10kHz	50kHz	100kHz≤
~ 4.7	0.40	0.60	0.80	0.90	1.00
6.8 ~ 10	0.40	0.70	0.90	0.95	1.00
22 ~	0.50	0.80	0.90	0.95	1.00

# MINIATURE ALUMINUM ELECTROLYTIC CAPACITORS

**KU** For PSU, High Ripple Current, Long Life Series

- High ripple current
- High reliability withstanding 5000 hours load life at 105°C
- Suited for ballast application
- Complied to the RoHS directive

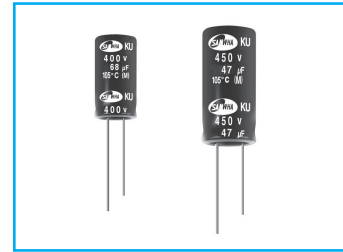
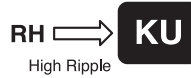

Item	Characteristics		
Operating temperature range	WV	400 ~ 450	500
	Temperature range	-40 ~ +105°C	-25 ~ +105°C
Leakage current max.	I = 0.02CV + 15μA (after 5 minutes)		
Capacitance tolerance	±20% at 120Hz, 20°C		
Dissipation factor max.	0.24max. at 120Hz, 20°C		
Low temperature characteristics (Impedance ratio at 120Hz)	WV	400 ~450	500
	Z-25°C/Z+20°C	6	6
	Z-40°C/Z+20°C	10	-
Load life	After an application of DC bias voltage plus the rated AC ripple current for 5000 hours at 105°C. The measurement shall meet the following limits. The DC voltage plus the peak AC voltage combined must not exceed the rated voltage.		
	Leakage current	Less than specified value	
	Capacitance change	Within ±20% of initial value	
	tanδ	Less than 200% of specified value	
Shelf life (at 105°C)	After 1000 hours no load test, leakage current, capacitance and tanδ are same as load life value. The measurement shall be performed at 20°C by the KS C IEC 60384 - 4		

● DRAWING (See page 89)

Unit : mm

● FREQUENCY COEFFICIENT OF PERMISSIBLE RIPPLE CURRENT

μF \ Frequency	60Hz	120Hz	1kHz	10kHz	50kHz	100kHz ≤
~ 4.7	0.25	0.30	0.60	0.80	0.90	1.00
6.8 ~ 15	0.30	0.40	0.70	0.90	0.95	1.00
22 ~	0.40	0.50	0.80	0.90	0.95	1.00

## KU series

### ● DIMENSIONS & MAXIMUM PERMISSIBLE RIPPLE CURRENT

WV Item $\mu\text{F}$	400		420		450		500	
	$\text{ØD} \times \text{L}(\text{mm})$	Ripple current (mA rms) 105°C, 100kHz	$\text{ØD} \times \text{L}(\text{mm})$	Ripple current (mA rms) 105°C, 100kHz	$\text{ØD} \times \text{L}(\text{mm})$	Ripple current (mA rms) 105°C, 100kHz	$\text{ØD} \times \text{L}(\text{mm})$	Ripple current (mA rms) 105°C, 100kHz
1.0	10×12.5	108						
2.2	10×12.5	120	10×12.5	120	10×12.5	120		
3.3	10×12.5	154	10×12.5	154	10×12.5	154		
4.7	10×16	216	10×16	216	10×20	216		
6.8	10×16	240	10×16	240	10×20	240		
10	10×20	336	10×20	336	12.5×20	360	12.5×20	360
15	12.5×16	336					12.5×25	432
22	12.5×25	516	12.5×25	516	12.5×25	516	16×25	504
33	16×25	768	16×25	792	16×25	768	16×31.5	672
47	16×31.5	900	16×31.5	900	16×31.5	840	18×35.5	840
56			18×25	900	18×25	900	18×35.5	888
68	16×31.5	1056	16×31.5	1080	16×35.5	1200	16×45	1080
82	16×35.5	1200	16×40	1260	16×35.5	1242	16×45	1236
100	18×35.5	1344	16×45	1440	16×45	1450	16×50	1320
120	18×40	1500	18×40	1536	16×50	1620	20×41	1570
150	20×41	1656	20×41	1800				

# MINIATURE ALUMINUM ELECTROLYTIC CAPACITORS

## BL For PSU, High Ripple Current, Long Life Series

- High ripple current
- Operating temperature range of -40 ~ +105°C
- For power supply and adapter
- Complied to the RoHS directive

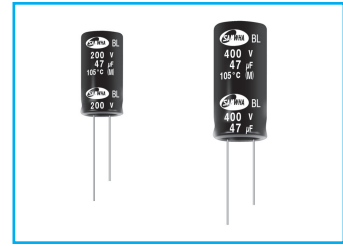

Item	Characteristics									
Operating temperature range	-40 ~ +105°C (160 ~ 450WV), -25 ~ +105°C (500WV)									
Leakage current max.	$I = 0.02CV + 25\mu A$ (after 5 minutes)									
Capacitance tolerance	$\pm 20\%$ at 120Hz, 20°C									
Dissipation factor max. (at 120Hz, 20°C)	WV	160	200	250	350	400	420	450	500	
	tan $\delta$	0.15	0.15	0.15	0.20	0.20	0.20	0.20	0.24	
Low temperature characteristics (Impedance ratio at 120Hz)	WV	160	200	250	350	400	420	450	500	
	Z-25°C/Z+20°C	3	3	3	4	6	6	6	6	
	Z-40°C/Z+20°C	4	4	4	6	6	6	6	-	
Load life	After an application of DC bias voltage plus the rated AC ripple current for 10000 hours at 105°C. The measurement shall meet the following limits. The DC voltage plus the peak AC voltage combined must not exceed the rated voltage.									
	Leakage current	Less than specified value								
	Capacitance change	Within $\pm 20\%$ of initial value								
	tan $\delta$	Less than 200% of specified value								
Shelf life (at 105°C)	After 1000 hours no load test, leakage current, capacitance and tan $\delta$ are same as load life value. The measurement shall be performed at 20°C by the KS C IEC 60384 - 4									

### ● DRAWING

Unit : mm

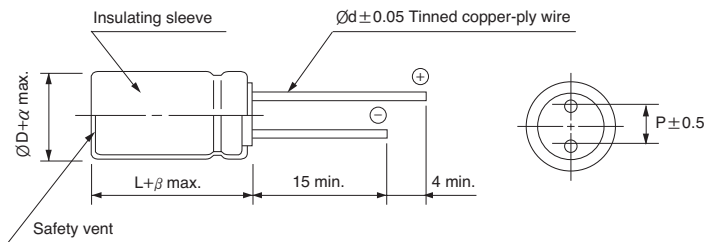

ØD	8	10	12.5	16	18	20
P	3.5	5.0	5.0	7.5	7.5	10.0
Ød	0.6	0.6	0.6	0.8	0.8	0.8
α	0.5					1.0
β	1.5	2.0			3.0	

### ● FREQUENCY COEFFICIENT OF PERMISSIBLE RIPPLE CURRENT

Frequency	60Hz	120Hz	1kHz	10kHz	50kHz	100kHz $\leq$
Coefficient	0.35	0.50	0.80	0.90	0.95	1.00

## BL series

### ● DIMENSIONS & MAXIMUM PERMISSIBLE RIPPLE CURRENT

$\mu\text{F}$ \diagdown WV	160		200		250		350	
4.7					8 × 11.5	193		
6.8					8 × 11.5	220	10 × 16	264
					10 × 12.5	230		
10	10 × 16	320	10 × 16	320	10 × 16	320	8 × 20	315
22	10 × 16	500	10 × 16	500	10 × 20	500	10 × 20	340
33	10 × 20	650	10 × 20	650	12.5 × 20	770	12.5 × 20	424
47	10 × 20	750	12.5 × 20	840	12.5 × 20	980	16 × 20	605
68	12.5 × 20	970	12.5 × 25	970	16 × 20	1080	16 × 25	800
82	12.5 × 25	1250	16 × 20	1125			18 × 25	1020
					16 × 20	1190	18 × 31.5	1090
100	12.5 × 25	1250	16 × 20	1230	18 × 25	1425		
150	16 × 25	1610	18 × 25	1740	18 × 25	2000		

$\mu\text{F}$ \diagdown WV	400		420		450		500	
1	8 × 11.5	72			8 × 11.5	100		
2.2	8 × 11.5	99			8 × 11.5	110		
3.3	8 × 11.5	160			8 × 11.5	160		
3.9	8 × 11.5	170			8 × 15	180		
4.7	8 × 15	175			8 × 20	240		
	10 × 12.5	230			10 × 16	240		
6.8	8 × 20	230			10 × 16	265		
	10 × 16	265						
10	10 × 20	340	10 × 20	360	10 × 20	385	12.5 × 25	385
15					10 × 20	385		
22	12.5 × 25	520	12.5 × 25	520	12.5 × 20	485	16 × 25	675
			16 × 20	520	12.5 × 25	485	16 × 31.5	820
				16 × 25	675			
33	16 × 25	775	16 × 25	825	18 × 25	845	18 × 35.5	870
47	18 × 25	1020	18 × 31.5	1015	18 × 31.5	1060	18 × 35.5	1000
68	18 × 31.5	1050	18 × 25	1090	18 × 25	1200	18 × 35.5	1200
			18 × 31.5	1125	18 × 31.5	1200	18 × 40	1300
82	18 × 35.5	1150	18 × 31.5	1210	18 × 35.5	1270	16 × 50	1350
100	18 × 40	1210	18 × 35.5	1270	18 × 35.5	1330		
			18 × 40	1330	18 × 40	1400		
120					18 × 40	1450		
150					20 × 41	1550		

Ripple current (mA rms) at 105°C, 100kHz  
 Case size  $\varnothing D \times L$  (mm)

# MINIATURE ALUMINUM ELECTROLYTIC CAPACITORS

**MT** For Display, 12000 hours at 105°C Series

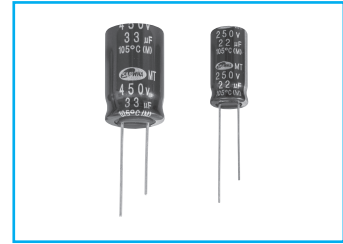

- High reliability withstanding 12000 Hours load life at 105°C
- For power supply and adapter
- Complied to the RoHS directive

Item	Characteristics									
Operating temperature range	-40 ~ +105°C									
Leakage current max.	I = 0.04CV+100μA (after 1 minutes) I = 0.02CV+25μA (after 5 minutes)									
Capacitance tolerance	±20% at 120Hz, 20°C									
Dissipation factor max. (at 120Hz, 20°C)	WV	160	200	250	350	400	420	450	500	
	tanδ	0.20			0.24					
Low temperature characteristics (Impedance ratio at 120Hz)	WV	160	200	250	350	400	420	450	500	
	Z-25°C/Z+20°C	3	3	3	3	6	6	6	6	
	Z-40°C/Z+20°C	4	4	4	6	6	6	6	6	
Load life	After an application of DC bias voltage plus the rated AC ripple current for 12000 hours at 105°C. The measurement shall meet the following limits. The DC voltage plus the peak AC voltage combined must not exceed the rated voltage.									
	Leakage current	Less than specified value								
	Capacitance change	Within ±20% of initial value								
	tanδ	Less than 200% of specified value								
Shelf life (at 105°C)	After 1000 hours no load test, leakage current, capacitance and tanδ are same as load life value. The measurement shall be performed at 20°C by the KS C IEC 60384 - 4									

## ● DRAWING

Unit : mm

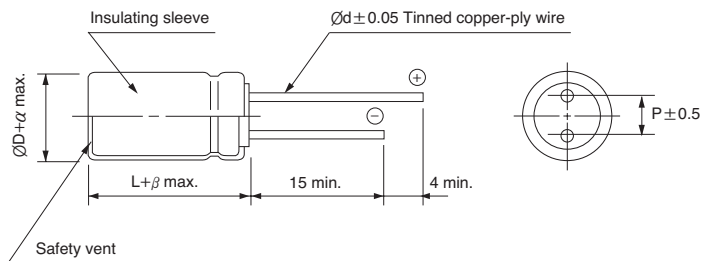

ØD	10	12.5	16	18	20
P	5.0	5.0	7.5	7.5	10.0
Ød	0.6	0.6	0.8	0.8	0.8
α	0.5				1.0
β	2.0				3.0

## ● FREQUENCY COEFFICIENT OF PERMISSIBLE RIPPLE CURRENT

μF	Frequency	120Hz	1kHz	10kHz	50kHz	100kHz≤
10 ~ 82		1.00	1.75	2.25	2.45	2.50
100 ~ 470		1.00	1.67	2.05	2.20	2.25

## MT series

### ● DIMENSIONS & MAXIMUM PERMISSIBLE RIPPLE CURRENT

$\mu\text{F}$ \diagdown WV	160		200		250		350	
10	10 × 16	102	10 × 16	110	10 × 12.5	110	10 × 16	135
22	10 × 16	195	10 × 16	200	10 × 16	195	12.5 × 20	270
27	10 × 16	222	10 × 16	222	10 × 20	240	12.5 × 20	285
33	10 × 16	245	10 × 20	280	12.5 × 20	294	12.5 × 25	290
39	10 × 16	265	10 × 20	305	12.5 × 20	322	12.5 × 25	320
47	10 × 20	335	10 × 20	335	12.5 × 20	400	16 × 25	410
			12.5 × 20	400				
68	12.5 × 20	400	12.5 × 20	447	12.5 × 25	540	16 × 25	550
			12.5 × 25	540		16 × 20		
82	12.5 × 20	450	12.5 × 25	560	16 × 20	600	18 × 25	625
			16 × 20	560				
100	12.5 × 25	525	16 × 25	652	16 × 25	652	18 × 31.5	743
	16 × 20	525			18 × 20	652		
120	12.5 × 25	580	16 × 25	714	16 × 25	714	18 × 35.5	840
	16 × 25	580						
150	16 × 25	750	16 × 25	760	18 × 25	820	18 × 35.5	942
180	16 × 25	810	16 × 31.5	850	18 × 31.5	920		
220	16 × 31.5	880	18 × 31.5	1000	18 × 31.5	1000		
	18 × 25	880						
270	16 × 35.5	1000	18 × 35.5	1150				
330	16 × 40	1142	18 × 40	1250				
	18 × 31.5	1119						
470	18 × 40	1401						

$\mu\text{F}$ \diagdown WV	400		420		450		500	
10	10 × 16	135	10 × 20	135	10 × 20	135	12.5 × 20	165
22	12.5 × 20	270	12.5 × 20	225	12.5 × 25	296	16 × 20	260
27	12.5 × 25	285	12.5 × 20	254	12.5 × 25	305	16 × 25	329
33	12.5 × 25	320	16 × 20	345	16 × 20	364	16 × 25	350
39	12.5 × 30	320	16 × 25	345	16 × 25	400	16 × 31.5	413
47	16 × 25	420	16 × 25	450	16 × 25	450	16 × 35.5	462
	18 × 20	436	18 × 20	450	18 × 20	450	18 × 31.5	468
68	16 × 31.5	540	18 × 25	520	18 × 25	560	16 × 45	630
	18 × 25	540	18 × 31.5	580	18 × 31.5	590	18 × 35.5	600
82	18 × 31.5	700	18 × 31.5	650	16 × 40	650	16 × 50	685
					18 × 31.5	670	18 × 40	670
100	18 × 31.5	743	16 × 45	770	16 × 45	770	18 × 45	800
	18 × 35.5	820	18 × 35.5	770	18 × 35.5	790	20 × 41	800
120	18 × 35.5	840	16 × 50	850	16 × 50	850	18 × 50	920
	18 × 40	912	18 × 40	850	18 × 40	850		
150	18 × 40	1020	18 × 45	1000				
			20 × 41	1000				
180	20 × 41	1080						

Ripple current (mA rms) at 105°C, 120Hz  
 Case size  $\varnothing D \times L$  (mm)



# MINIATURE ALUMINUM ELECTROLYTIC CAPACITORS

**KJ** For PSU, High Ripple, Long Life Series

- High reliability withstanding 12000 hours load life at 105°C
- Suitable for CFL, adapter and power supply
- Complied to the RoHS directive

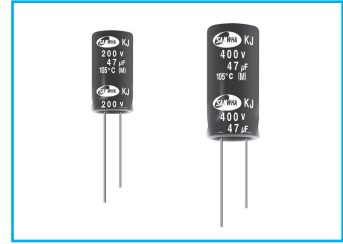

Item	Characteristics								
Operating temperature range	-40 ~ +105°C (160 ~ 450WV), -25 ~ +105°C (500WV)								
Leakage current max.	I = 0.04CV + 100µA (after 1 minute) I = 0.02CV + 25µA (after 5 minutes)								
Capacitance tolerance	±20% at 120Hz, 20°C								
Dissipation factor max. (at 120Hz, 20°C)	WV	160	200	250	350	400	420	450	500
	tanδ	0.15	0.15	0.15	0.20	0.20	0.20	0.20	0.24
Low temperature characteristics (Impedance ratio at 120Hz)	WV	160	200	250	350	400	420	450	500
	Z-25°C/Z+20°C	3	3	3	6	6	6	6	6
	Z-40°C/Z+20°C	4	4	4	10	10	10	10	-
Load life	After an application of DC bias voltage plus the rated AC ripple current for 12000 hours at 105°C. The measurement shall meet the following limits. The DC voltage plus the peak AC voltage combined must not exceed the rated voltage.								
	Leakage current	Less than specified value							
	Capacitance change	Within ±20% of initial value							
	tanδ	Less than 200% of specified value							
Shelf life (at 105°C)	After 1000 hours no load test, leakage current, capacitance and tanδ are same as load life value. The measurement shall be performed at 20°C by the KS C IEC 60384 - 4								

## ● DRAWING

Unit : mm

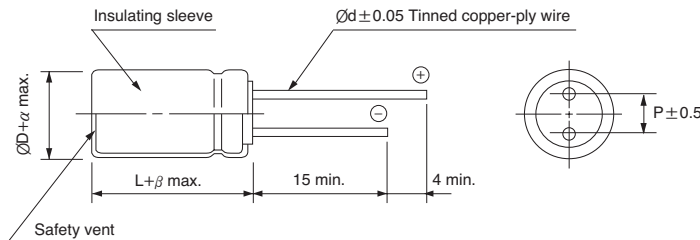

ØD	8	10	12.5	16	18	20
P	3.5	5.0	5.0	7.5	7.5	10.0
Ød	0.6	0.6	0.6	0.8	0.8	0.8
α	0.5					1.0
β	1.5	2.0			3.0	

## ● FREQUENCY COEFFICIENT OF PERMISSIBLE RIPPLE CURRENT

WV	µF	Frequency	120Hz	300Hz	1kHz	10kHz	50kHz	100kHz ≤
		~ 15	0.30	0.50	0.60	0.90	0.95	1.00
160~450	22 ~ 47	0.40	0.50	0.70	0.90	0.95	1.00	
	68 ~	0.50	0.60	0.80	0.90	0.95	1.00	
	~ 39	0.40	0.50	0.70	0.90	0.95	1.00	
500	~ 39	0.40	0.50	0.70	0.90	0.95	1.00	
	47 ~	0.50	0.60	0.80	0.90	0.95	1.00	

## KJ series

### ● DIMENSIONS & MAXIMUM PERMISSIBLE RIPPLE CURRENT

$\mu\text{F}$ \diagdown WV	160		200		250		350	
4.7					8 × 11.5	193	10 × 12.5	198
6.8					8 × 11.5	220	10 × 16	308
					10 × 12.5	319		
10	10 × 16	358	10 × 16	407	8 × 15	292	8 × 20	424
					10 × 16	407	10 × 20	462
22	10 × 16	572	10 × 20	638	10 × 20	580	12.5 × 20	743
27	10 × 16	611	10 × 20	638	10 × 20	660	12.5 × 20	784
33	10 × 16	690	10 × 20	825	12.5 × 20	853	16 × 20	858
39	10 × 20	759	12.5 × 20	839	12.5 × 20	886	16 × 20	880
47	10 × 20	924	12.5 × 20	1100	12.5 × 20	1100	16 × 25	1130
68	12.5 × 20	924	12.5 × 25	1188	16 × 20	1210	18 × 25	1220
			16 × 20	1210				
82	12.5 × 25	1040	16 × 25	1232	16 × 20	1340	18 × 25	1380
100	12.5 × 25	1210	16 × 25	1434	16 × 25	1540	18 × 31.5	1617
	16 × 20				18 × 20			
120	16 × 25	1325	16 × 25	1571	18 × 25	1645	18 × 35.5	1848
150	16 × 25	1645	18 × 25	1727	18 × 25	1914	18 × 40	2072
180	16 × 25	1782	18 × 25	1760	18 × 31.5	2024	20 × 41	2310
220	18 × 25	2090	18 × 31.5	2222	18 × 35.5	2200		
270	16 × 35.5	2200	18 × 35.5	2530				
330	16 × 40	2508	18 × 40	2750				
470	18 × 45	3084						

$\mu\text{F}$ \diagdown WV	400		420		450		500	
1	8 × 11.5	72			8 × 11.5	90		
2.2	8 × 11.5	99			8 × 11.5	105		
3.3	8 × 11.5	160			8 × 11.5	145		
3.9	8 × 11.5	171			8 × 15	165		
4.7	8 × 15	176			8 × 20	242		
	10 × 12.5	242			10 × 12.5	242		
6.8	8 × 20	231			10 × 16	363		
	10 × 16	308			10 × 20	440		
10	10 × 20	462	10 × 20	462	10 × 20	440	12.5 × 20	413
					12.5 × 20	528		
15	12.5 × 20	528	12.5 × 20	528	12.5 × 20	528	12.5 × 25	440
					12.5 × 25	660		
22	12.5 × 25	792	12.5 × 25	745	12.5 × 25	890	16 × 20	500
			16 × 20	780	16 × 20	900	16 × 25	675
27	16 × 20	803	16 × 20	875	16 × 20	950	16 × 25	823
33	16 × 20	960	12.5 × 30	980	16 × 25	1095	16 × 31.5	880
			16 × 25	1035	18 × 20		18 × 25	
39	16 × 20	1000	16 × 25	1050	16 × 25	1100	16 × 31.5	1033
47	16 × 25	1188	16 × 25	1125	18 × 25	1150	18 × 25	1000
	18 × 20						18 × 31.5	1033
68	16 × 31.5	1309	18 × 25	1265	18 × 31.5	1180	18 × 35.5	1100
							18 × 40	1200
82	18 × 31.5	1639	18 × 31.5	1450	18 × 35.5	1430	18 × 35.5	1250
							18 × 40	1340
100	18 × 35.5	1810	18 × 35.5	1700	18 × 35.5	1740	18 × 45	1400
					18 × 40	1740	20 × 41	1600
120	18 × 40	2006	18 × 40	1700	18 × 45	1740		
150	20 × 41	2244	20 × 41	2000				

WV  
 Ripple current (mA rms) at 105°C, 100kHz  
 Case size  $\varnothing D \times L$  (mm)

# MINIATURE ALUMINUM ELECTROLYTIC CAPACITORS

**BN** For Network, High Ripple, 12000 hours at 105°C Series

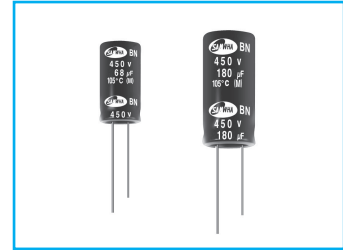

- High reliability withstanding 12000 hours load life at 105°C
- For DC-DC convertor
- Complied to the RoHS directive

Item	Characteristics		
Operating temperature range	-40 ~ +105°C		
Leakage current max.	I = 0.04CV + 100µA (after 1 minute) I = 0.02CV + 25µA (after 5 minutes)		
Capacitance tolerance	±20% at 120Hz, 20°C		
Dissipation factor max. (at 120Hz, 20°C)	WV	400 ~ 500	
	tanδ	0.24	
Low temperature characteristics (Impedance ratio at 120Hz)	WV	400, 450	500
	Z-25°C/Z+20°C	6	6
	Z-40°C/Z+20°C	6	11
Load life	After an application of DC bias voltage plus the rated AC ripple current for 12000 hours at 105°C. The measurement shall meet the following limits. The DC voltage plus the peak AC voltage combined must not exceed the rated voltage.		
	Leakage current	Less than specified value	
	Capacitance change	Within ±30% of initial value	
Shelf life (at 105°C)	After 1000 hours no load test, leakage current, capacitance and tanδ are same as load life value. The measurement shall be performed at 20°C by the KS C IEC 60384 - 4		

## ● DRAWING

Unit : mm

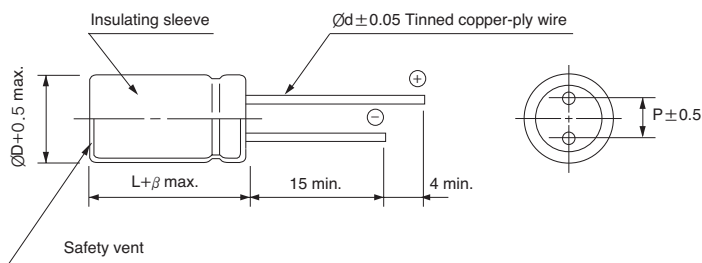

ØD	18	
P	7.5	
Ød	0.8	
β	L ≤ 40mm	2.0
	L ≥ 40mm	3.0

## ● DIMENSIONS & MAXIMUM PERMISSIBLE RIPPLE CURRENT

µF \ WV	400		450		500	
47	18 × 25	1150	18 × 25	1200	18 × 25	1350
68	18 × 25	1300	18 × 25	1500	18 × 31.5	1550
82	18 × 31.5	1400	18 × 31.5	1600	18 × 35.5	1650
100	18 × 31.5	1500	18 × 31.5	1700	18 × 40	1750
120	18 × 35.5	1700	18 × 35.5	1900	18 × 45	1950
150	18 × 40	1850	18 × 40	2000	18 × 50	2050
180	18 × 45	2050	18 × 45	2180		

↑ ↑  
Ripple current (mA rms) at 105°C, 100kHz  
Case size ØD × L (mm)

## ● FREQUENCY COEFFICIENT OF PERMISSIBLE RIPPLE CURRENT

Frequency	120Hz	1kHz	10kHz	50kHz	100kHz ≤
Coefficient	0.50	0.80	0.90	0.95	1.00

## MP For Display, 15000 hours at 105°C Series

- High reliability withstanding 15000 hours load life at 105°C
- For power supply and adapter
- Complied to the RoHS directive

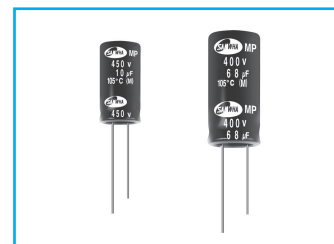

Item	Characteristics									
Operating temperature range	-40 ~ +105°C									
Leakage current max.	I = 0.04CV+100µA (after 1 minute) I = 0.02CV+25µA (after 5 minutes)									
Capacitance tolerance	±20% at 120Hz, 20°C									
Dissipation factor max. (at 120Hz, 20°C)	WV	160	200	250	350	400	420	450	500	
	tanδ	0.20			0.24					
Low temperature characteristics (Impedance ratio at 120Hz)	WV	160	200	250	350	400	420	450	500	
	Z-25°C/Z+20°C	3	3	3	3	6	6	6	6	
	Z-40°C/Z+20°C	4	4	4	6	6	6	6	6	
Load life	After an application of DC bias voltage plus the rated AC ripple current for 15000 hours at 105°C. The measurement shall meet the following limits. The DC voltage plus the peak AC voltage combined must not exceed the rated voltage. (where 12000 hours for Ø10)									
	Leakage current	Less than specified value								
	Capacitance change	Within ±20% of initial value								
	tanδ	Less than 200% of specified value								
Shelf life (at 105°C)	After 1000 hours no load test, leakage current, capacitance and tanδ are same as load life value. The measurement shall be performed at 20°C by the KS C IEC 60384 - 4									

### ● DRAWING

Unit : mm

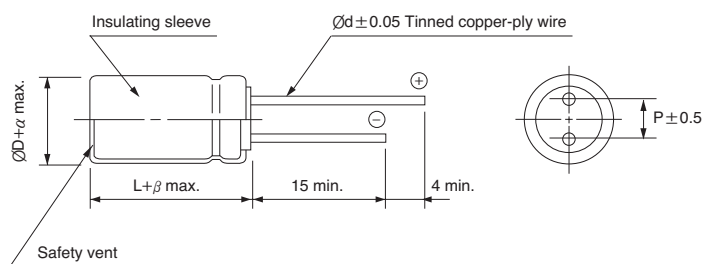

ØD	10	12.5	16	18
P	5.0	5.0	7.5	7.5
Ød	0.6	0.6	0.8	0.8
α	0.5			
β	2.0			

### ● FREQUENCY COEFFICIENT OF PERMISSIBLE RIPPLE CURRENT

µF \ Frequency	120Hz	1kHz	10kHz	50kHz	100kHz ≤
10 ~ 82	1.00	1.75	2.25	2.35	2.50
100 ~ 470	1.00	1.67	2.05	2.15	2.25

MINIATURE TYPES

# MINIATURE ALUMINUM ELECTROLYTIC CAPACITORS

**MP** series

● DIMENSIONS & MAXIMUM PERMISSIBLE RIPPLE CURRENT

$\mu\text{F}$ \diagdown WV	160		200		250		350	
10	10 × 12.5	110	10 × 12.5	110	10 × 12.5	160	10 × 16	149
15	10 × 12.5	150	10 × 12.5	150	10 × 16	220	10 × 20	197
22	10 × 12.5	243	10 × 16	243	10 × 20	240	12.5 × 20	297
27	10 × 16	264	10 × 20	280	10 × 20	270	12.5 × 20	314
33	10 × 16	270	10 × 20	308	12.5 × 20	323	12.5 × 25	325
39	10 × 20	320	12.5 × 20	350	12.5 × 20	354	12.5 × 30	352
47	10 × 20	369	12.5 × 20	440	12.5 × 25	460	16 × 20	451
68	12.5 × 20	480	12.5 × 25	594	12.5 × 30	610	16 × 31.5	623
82	12.5 × 25	525	16 × 20	616	16 × 25	680	18 × 25	688
100	12.5 × 25	575	16 × 25	717	16 × 31.5	717	18 × 31.5	817
120	12.5 × 30	670	16 × 25	785	16 × 31.5	804	18 × 35.5	924
	16 × 25	670						
150	16 × 25	825	16 × 31.5	813	16 × 35.5	902	18 × 40	1083
180	16 × 25	591	16 × 35.5	951	18 × 35.5	1012	18 × 45	1230
220	16 × 31.5	968	18 × 31.5	1100	18 × 40	1121		
	18 × 25	968						
270	16 × 35.5	1100	18 × 40	1290				
330	16 × 40	1231	18 × 45	1390				
	18 × 31.5	1231						
470	18 × 45	1626						

$\mu\text{F}$ \diagdown WV	400		420		450		500	
10	10 × 16	145	10 × 20	135	10 × 20	135	12.5 × 20	165
22	12.5 × 20	297	12.5 × 25	250	12.5 × 25	296	16 × 20	260
27	12.5 × 25	330	12.5 × 25	265	12.5 × 25	305	16 × 25	329
33	12.5 × 30	355	16 × 20	345	16 × 20	364	16 × 31.5	380
39	16 × 25	400	16 × 25	400	16 × 31.5	423	16 × 35.5	434
47	16 × 25	480	16 × 25	450	16 × 31.5	478	18 × 31.5	468
68	16 × 35.5	627	18 × 31.5	580	18 × 31.5	590	18 × 40	630
82	16 × 40	770	18 × 31.5	650	18 × 31.5	670	18 × 40	670
100	18 × 35.5	875	18 × 35.5	770	18 × 40	794	18 × 45	800
120	18 × 40	1000	18 × 45	900	18 × 45	940	18 × 50	920
150	18 × 45	1150						

↑  
 ↑  
 — Ripple current (mA rms) at 105°C, 120Hz  
 — Case size  $\varnothing D \times L$  (mm)

# MINIATURE ALUMINUM ELECTROLYTIC CAPACITORS



# MJ

For PSU, High Ripple, 20000 hours at 105°C Series

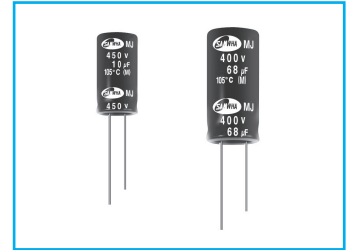

- High reliability withstanding 20000 hours load life at 105°C
- For power supply and adapter
- Complied to the RoHS directive



Item	Characteristics																											
<b>Operating temperature range</b>	-40 ~ +105°C (160 ~ 450WV), -25 ~ +105°C (500WV)																											
<b>Leakage current max.</b>	I = 0.04CV + 100µA (after 1 minute) I = 0.02CV + 25µA (after 5 minutes)																											
<b>Capacitance tolerance</b>	±20% at 120Hz, 20°C																											
<b>Dissipation factor max. (at 120Hz, 20°C)</b>	<table border="1"> <tr> <td>WV</td> <td>160</td> <td>200</td> <td>250</td> <td>350</td> <td>400</td> <td>420</td> <td>450</td> <td>500</td> </tr> <tr> <td>tanδ</td> <td colspan="3">0.20</td> <td colspan="6">0.24</td> </tr> </table>	WV	160	200	250	350	400	420	450	500	tanδ	0.20			0.24													
	WV	160	200	250	350	400	420	450	500																			
tanδ	0.20			0.24																								
<b>Low temperature characteristics (Impedance ratio at 120Hz)</b>	<table border="1"> <tr> <td>WV</td> <td>160</td> <td>200</td> <td>250</td> <td>350</td> <td>400</td> <td>420</td> <td>450</td> <td>500</td> </tr> <tr> <td>Z-25°C/Z+20°C</td> <td>3</td> <td>3</td> <td>3</td> <td>3</td> <td>6</td> <td>6</td> <td>6</td> <td>6</td> </tr> <tr> <td>Z-40°C/Z+20°C</td> <td>4</td> <td>4</td> <td>4</td> <td>6</td> <td>6</td> <td>6</td> <td>6</td> <td>-</td> </tr> </table>	WV	160	200	250	350	400	420	450	500	Z-25°C/Z+20°C	3	3	3	3	6	6	6	6	Z-40°C/Z+20°C	4	4	4	6	6	6	6	-
WV	160	200	250	350	400	420	450	500																				
Z-25°C/Z+20°C	3	3	3	3	6	6	6	6																				
Z-40°C/Z+20°C	4	4	4	6	6	6	6	-																				
<b>Load life</b>	After an application of DC bias voltage plus the rated AC ripple current for 20000 hours at 105°C. The measurement shall meet the following limits. The DC voltage plus the peak AC voltage combined must not exceed the rated voltage. (where 15000 hours for Ø10)																											
	Leakage current	Less than specified value																										
	Capacitance change	Within ±20% of initial value																										
	tanδ	Less than 200% of specified value																										
<b>Shelf life (at 105°C)</b>	After 1000 hours no load test, leakage current, capacitance and tanδ are same as load life value. The measurement shall be performed at 20°C by the KS C IEC 60384 - 4																											

## ● DRAWING

Unit : mm

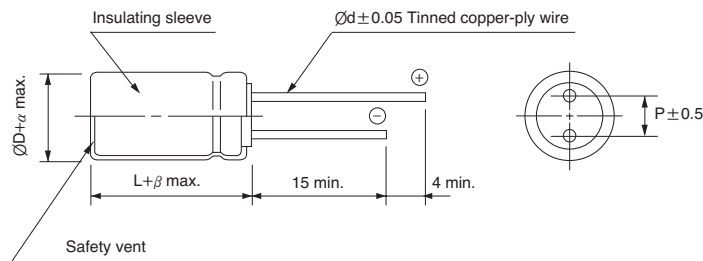

ØD	10	12.5	16	18	22
P	5.0	5.0	7.5	7.5	10.0
Ød	0.6	0.6	0.8	0.8	1.0
α	0.5			1.0	
β	2.0			3.0	

## ● FREQUENCY COEFFICIENT OF PERMISSIBLE RIPPLE CURRENT

µF \ Frequency	120Hz	1kHz	10kHz	50kHz	100kHz ≤
3.3 ~ 82	1.00	1.75	2.25	2.35	2.50
100 ~ 470	1.00	1.67	2.05	2.15	2.25

MINIATURE TYPES

# MINIATURE ALUMINUM ELECTROLYTIC CAPACITORS

**MJ** series

● DIMENSIONS & MAXIMUM PERMISSIBLE RIPPLE CURRENT

$\mu\text{F}$ \diagdown WV	160		200		250		350	
6.8					10 × 12.5	119	10 × 12.5	105
10					10 × 12.5	160	10 × 16	149
15			10 × 12.5	150	10 × 16	220	10 × 20	197
22	10 × 12.5	221	10 × 16	243	10 × 20	240	12.5 × 20	297
	10 × 16	243						
27	10 × 16	264	10 × 20	280	10 × 20	270	12.5 × 20	314
33	10 × 16	270	10 × 20	308	12.5 × 20	323	12.5 × 25	325
39	10 × 20	320	12.5 × 20	350	12.5 × 20	354	12.5 × 25	352
47	10 × 20	369	12.5 × 20	440	12.5 × 25	460	12.5 × 30	451
68	12.5 × 25	480	12.5 × 25	594	12.5 × 30	610	16 × 31.5	623
82	12.5 × 25	525	12.5 × 30	640	16 × 25	680	18 × 25	688
			16 × 20	616				
100	12.5 × 25	575	16 × 25	717	16 × 25	717	18 × 31.5	817
120	12.5 × 30	670	16 × 25	785	16 × 31.5	804	18 × 35.5	924
150	16 × 25	825	16 × 31.5	813	16 × 35.5	902	18 × 40	1083
180	16 × 25	891	16 × 35.5	951	18 × 31.5	1012	18 × 45	1230
220	16 × 31.5	968	18 × 31.5	1100	18 × 35.5	1121		
	18 × 25	968						
270	16 × 35.5	1100	18 × 40	1290				
330	18 × 31.5	1231	18 × 45	1390				
470	18 × 45	1626						

$\mu\text{F}$ \diagdown WV	400		420		450		500	
3.3							10 × 12.5	63
4.7					10 × 12.5	76	10 × 16	83
6.8	10 × 16	85			10 × 16	110	10 × 20	119
8.2	10 × 16	140	10 × 16	113	10 × 20	122	10 × 20	141
10	10 × 16	145	10 × 20	135	10 × 20	135	12.5 × 20	165
22	12.5 × 20	297	12.5 × 25	250	12.5 × 20	296	16 × 25	260
					12.5 × 25	296		
27	12.5 × 25	330	12.5 × 25	265	12.5 × 30	305	16 × 25	329
33	12.5 × 30	355	12.5 × 30	340	16 × 25	364	16 × 31.5	380
			16 × 20	345				
39	16 × 25	400	16 × 25	400	16 × 31.5	423	16 × 35.5	434
47	16 × 25	480	16 × 25	450	16 × 31.5	478	18 × 31.5	468
68	16 × 35.5	627	18 × 31.5	580	18 × 31.5	590	18 × 40	630
82	16 × 40	770	16 × 40	620	18 × 35.5	670	18 × 45	685
100	18 × 35.5	875	18 × 35.5	770	18 × 40	794	18 × 50	800
							22 × 41	800
120	18 × 40	1003	18 × 45	900	18 × 50	940	22 × 51	960
150	18 × 50	1192						

↑  
 ↑  
 — Ripple current (mA rms) at 105°C, 120Hz  
 — Case size  $\varnothing D \times L$  (mm)

## RB High Temperature, For 125°C Use Series

**S**  
Solvent Proof  
WV ≤ 100V

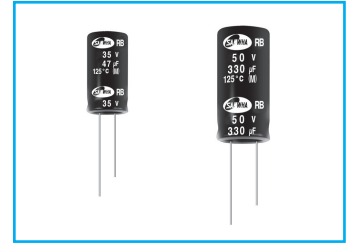

- Load life of 2000 hours at 125°C
- For Electronic Control unit and other high temperature applications
- Complied to the RoHS directive

Item	Characteristics																	
<b>Operating temperature range</b>	WV ≤ 50: -55 ~ +125°C, WV ≥ 63: -40 ~ +125°C																	
<b>Leakage current max.</b>	WV ≤ 50: I = 0.01CV or 3µA whichever is greater (after 2 minutes) WV ≥ 63: 0.03CV + 10µA (after 5 minutes)																	
<b>Capacitance tolerance</b>	±20% at 120Hz, 20°C																	
<b>Dissipation factor max. (at 120Hz, 20°C)</b>	Capacitance > 1000µF : tanδ increases by 0.02 for each 1000µF from below value.																	
	<table border="1"> <thead> <tr> <th>WV</th> <th>6.3</th> <th>10</th> <th>16</th> <th>25</th> <th>35</th> <th>50</th> <th>63 ~ 100</th> <th>160 ~ 250</th> </tr> </thead> <tbody> <tr> <td>tanδ</td> <td>0.22</td> <td>0.19</td> <td>0.16</td> <td>0.14</td> <td>0.12</td> <td>0.10</td> <td>0.08</td> <td>0.15</td> </tr> </tbody> </table>	WV	6.3	10	16	25	35	50	63 ~ 100	160 ~ 250	tanδ	0.22	0.19	0.16	0.14	0.12	0.10	0.08
WV	6.3	10	16	25	35	50	63 ~ 100	160 ~ 250										
tanδ	0.22	0.19	0.16	0.14	0.12	0.10	0.08	0.15										
<b>Low temperature characteristics (Impedance ratio at 120Hz)</b>	<table border="1"> <thead> <tr> <th>WV</th> <th>6.3 ~ 10</th> <th>16 ~ 250</th> </tr> </thead> <tbody> <tr> <td>Z-25°C/Z+20°C</td> <td>3</td> <td>2</td> </tr> <tr> <td>Z-40°C/Z+20°C</td> <td>5</td> <td>4</td> </tr> </tbody> </table>	WV	6.3 ~ 10	16 ~ 250	Z-25°C/Z+20°C	3	2	Z-40°C/Z+20°C	5	4								
	WV	6.3 ~ 10	16 ~ 250															
	Z-25°C/Z+20°C	3	2															
Z-40°C/Z+20°C	5	4																
<table border="1"> <tbody> <tr> <td>Leakage current</td> <td>Less than specified value</td> </tr> <tr> <td>Capacitance change</td> <td>Within ±20% of initial value</td> </tr> <tr> <td>tanδ</td> <td>Less than 300% of specified value</td> </tr> </tbody> </table>	Leakage current	Less than specified value	Capacitance change	Within ±20% of initial value	tanδ	Less than 300% of specified value												
Leakage current	Less than specified value																	
Capacitance change	Within ±20% of initial value																	
tanδ	Less than 300% of specified value																	
<b>Load life (after application of the rated voltage for 2000 hours at 125°C)</b>	Ø5, 6.3 and WV ≥ 100 products are for 1000 hours																	
<b>Shelf life (at 125°C)</b>	After 1000 hours no load test, leakage current, capacitance and tanδ are same as load life value. The measurement shall be performed at 20°C by the KS C IEC 60384 - 4																	

### ● DRAWING

Unit : mm

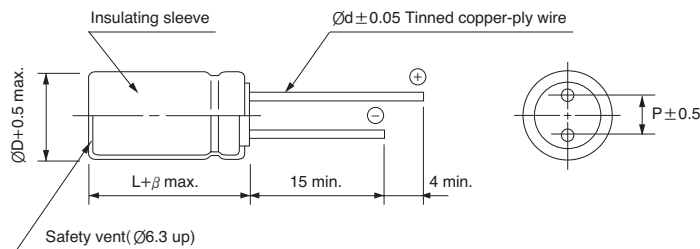

ØD	5	6.3	8	10	12.5	16	18
P	2.0	2.5	3.5	5.0	5.0	7.5	7.5
Ød	0.5	0.5	0.6	0.6	0.6	0.8	0.8
β	1.5			2.0			

### ● FREQUENCY COEFFICIENT OF PERMISSIBLE RIPPLE CURRENT

WV	µF	Frequency					
		60Hz	120Hz	1kHz	10kHz	50kHz	100kHz ≤
6.3~100	~ 47	0.38	0.50	0.78	1.00	1.00	1.00
	68 ~ 680	0.46	0.57	0.77	0.86	0.93	1.00
	1000 ~	0.57	0.67	0.77	0.77	0.88	1.00
160~250	1 ~ 33	0.44	0.56	0.78	0.89	0.94	1.00



# MINIATURE ALUMINUM ELECTROLYTIC CAPACITORS

**RB** series

● DIMENSIONS & MAXIMUM PERMISSIBLE RIPPLE CURRENT

WV Item $\mu$ F	6.3		10		16	
	$\varnothing D \times L$ (mm)	Ripple current (mA rms) 125°C 100kHz	$\varnothing D \times L$ (mm)	Ripple current (mA rms) 125°C 100kHz	$\varnothing D \times L$ (mm)	Ripple current (mA rms) 125°C 100kHz
47					5×11	165
68			5×11	165	6.3×11	230
100	5×11	160	6.3×11	220	6.3×11	280
150	6.3×11	240	6.3×11	280	8×11.5	410
220	6.3×11	300	8×11.5	410	8×11.5	485
330	8×11.5	310	8×11.5	485	10×12.5	660
470	10×12.5	605	10×12.5	635	10×16	815
680	10×16	740	10×16	815	10×20	1075
1000	10×20	1005	10×20	1120	12.5×20	1490
1500	12.5×20	1290	12.5×20	1495	12.5×25	1755
2200	12.5×20	1520	12.5×25	1805	16×20	1900
3300	12.5×25	1805	16×20	1955	16×25	2210
4700	16×25	2045	16×31.5	2555	16×35.5	2830
6800	16×31.5	2505	16×35.5	2830	18×35.5	3060
10000	16×40	2905	18×40	3210		
15000	18×40	3125				

WV Item $\mu$ F	25		35		50	
	$\varnothing D \times L$ (mm)	Ripple current (mA rms) 125°C 100kHz	$\varnothing D \times L$ (mm)	Ripple current (mA rms) 125°C 100kHz	$\varnothing D \times L$ (mm)	Ripple current (mA rms) 125°C 100kHz
1.0					5×11	40
1.5					5×11	50
2.2					5×11	55
3.3					5×11	70
4.7					5×11	85
6.8					5×11	95
10					5×11	120
15					5×11	155
22			5×11	170	6.3×11	205
33	5×11	165	6.3×11	240	6.3×11	255
47	6.3×11	220	6.3×11	285	8×11.5	365
68	6.3×11	275	8×11.5	405	8×11.5	435
100	8×11.5	405	8×11.5	485	10×16	615
150	8×11.5	485	10×12.5	660	10×20	865
220	10×12.5	635	10×16	815	12.5×20	1100
330	10×16	790	10×20	1120	12.5×20	1330
470	10×20	1075	12.5×20	1480	12.5×25	1585
680	12.5×20	1470	12.5×25	1755	16×20	1720
1000	12.5×25	1755	16×20	1870	16×31.5	2240
1500	16×20	1870	16×31.5	2520	16×40	2545
2200	16×25	2165	16×35.5	2830	18×40	2705
3300	16×35.5	2830	18×40	3210		
4700	18×40	3125				

## RB series

### ● DIMENSIONS & MAXIMUM PERMISSIBLE RIPPLE CURRENT

WV Item $\mu\text{F}$	63		100		160	
	$\text{ØD} \times \text{L}$ (mm)	Ripple current (mA rms) 125°C 100kHz	$\text{ØD} \times \text{L}$ (mm)	Ripple current (mA rms) 125°C 100kHz	$\text{ØD} \times \text{L}$ (mm)	Ripple current (mA rms) 125°C 100kHz
1.0			8×11.5	25	10×12.5	20
2.2			8×11.5	45	10×16	32
3.3			10×16	60	10×16	42
4.7			10×16	70	10×20	50
10	8×11.5	80	10×20	110	12.5×20	85
22	10×16	150	12.5×25	205	16×25	155
33	10×20	200	16×25	280	16×31.5	210
47	12.5×20	280	16×31.5	370		
100	12.5×25	445				

WV Item $\mu\text{F}$	200		250	
	$\text{ØD} \times \text{L}$ (mm)	Ripple current (mA rms) 125°C 100kHz	$\text{ØD} \times \text{L}$ (mm)	Ripple current (mA rms) 125°C 100kHz
1.0	10×12.5	20	10×12.5	18
2.2	10×16	32	10×16	32
3.3	10×20	42	10×20	42
4.7	10×20	50	12.5×20	60
10	12.5×20	95	16×25	105
22	16×31.5	170		

# MINIATURE ALUMINUM ELECTROLYTIC CAPACITORS

## WP Series 125°C, Low ESR, Long Life

- Downsize and long life
- Low ESR at -40°C
- Endurance with ripple current : 5000 hours at 125°C
- Complied to the RoHS directive

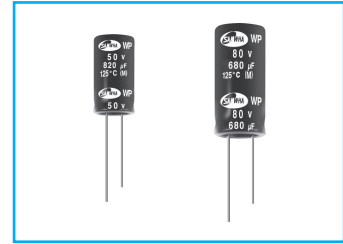

Item	Characteristics				
Operating temperature range	-40 ~ +125°C				
Leakage current max.	I = 0.01CV or 3μA whichever is greater (after 2 minutes)				
Capacitance tolerance	±20% at 120Hz, 20°C				
Dissipation factor max. (at 120Hz, 20°C)	Capacitance > 1000μF : tanδ increases by 0.02 for each 1000μF from below value.				
	WV	35	50	80	100
	tanδ	0.12	0.10	0.10	0.10
Low temperature characteristics (Impedance ratio at 120Hz)	WV	35	50	80	100
	Z-25°C/Z+20°C	2	2	2	2
	Z-40°C/Z+20°C	4	4	4	4
Load life (after application of the rated voltage for 5000 hours at 125°C)	Leakage current	Less than specified value			
	Capacitance change	Within ±30% of initial value			
	tanδ	Less than 300% of specified value			
Shelf life (at 125°C)	After 1000 hours no load test, leakage current, capacitance and tanδ are same as load life value. The measurement shall be performed at 20°C by the KS C IEC 60384 - 4				

### ● DRAWING

Unit : mm

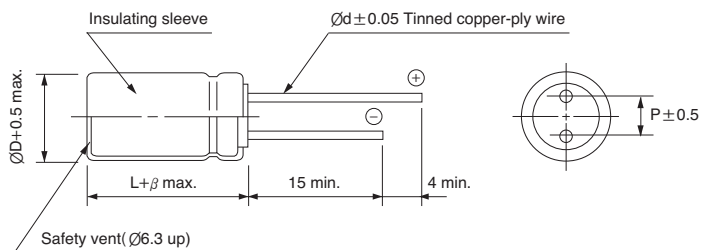

ØD	10	12.5	16	18
P	5.0	5.0	7.5	7.5
Ød	0.6	0.6	0.8	0.8
β	2.0			

### ● FREQUENCY COEFFICIENT OF PERMISSIBLE RIPPLE CURRENT

μF \ Frequency	120Hz	1kHz	10kHz	50kHz	100kHz ≤
270 ~ 560	0.50	0.85	0.95	0.99	1.00
680 ~ 1800	0.60	0.90	0.95	0.99	1.00
2200 ~ 3300	0.75	0.90	0.95	0.99	1.00
4700 ~	0.85	0.95	0.98	0.99	1.00

## WP series

### ● DIMENSIONS & MAXIMUM PERMISSIBLE RIPPLE CURRENT

WV Item μF	35			50		
	∅D×L (mm)	Impedance (Ω)max. 20°C 100kHz	Ripple current (mA rms) 125°C 100kHz	∅D×L (mm)	Impedance (Ω)max. 20°C 100kHz	Ripple current (mA rms) 125°C 100kHz
470				12.5 × 20	0.065	1500
560	10 × 20	0.070	1700	12.5 × 25	0.060	1700
680	12.5 × 20	0.044	1820	12.5 × 25	0.048	1900
				16 × 20	0.043	2040
820	12.5 × 25	0.042	2100	12.5 × 25	0.043	2150
				12.5 × 30	0.041	2150
1000	12.5 × 25	0.033	2400	16 × 25	0.031	2620
				18 × 20	0.039	2240
1200	12.5 × 30	0.029	2560	16 × 31.5	0.027	2940
	16 × 20	0.034	2280	18 × 25	0.029	2750
1500	18 × 20	0.032	2490	16 × 35.5	0.023	3300
1800	16 × 25	0.026	3100	18 × 31.5	0.026	3140
2200	16 × 31.5	0.023	3160	16 × 40	0.020	3720
	18 × 25	0.024	3200	18 × 35.5	0.022	3510
2700	16 × 35.5	0.020	3590	18 × 40	0.018	3940
	18 × 31.5	0.022	3390			
3300	16 × 40	0.017	4300			
	18 × 35.5	0.019	4200			
4700	18 × 40	0.016	4600			

WV Item μF	80			100		
	∅D×L (mm)	Impedance (Ω)max. 20°C 100kHz	Ripple current (mA rms) 125°C 100kHz	∅D×L (mm)	Impedance (Ω)max. 20°C 100kHz	Ripple current (mA rms) 125°C 100kHz
270				18 × 20	0.091	1690
300				16 × 25	0.079	1990
330	12.5 × 30	0.085	1790	16 × 31.5	0.065	2200
	16 × 20	0.085	1790			
470	16 × 25	0.061	2140	16 × 35.5	0.056	2500
	12.5 × 30	0.10	2140			
560	18 × 20	0.07	1910	16 × 40	0.046	2700
	16 × 31.5	0.053	2330			
680	18 × 25	0.049	2280	18 × 40	0.039	2880
	16 × 25	0.045	2300			
820	16 × 35.5	0.044	2580			
	16 × 40	0.036	2900			
1200	18 × 35.5	0.035	2890			
	18 × 40	0.030	3210			

# MINIATURE ALUMINUM ELECTROLYTIC CAPACITORS

**WT** High Temperature, For 125°C Use  
Long Life Series

- Load life of 5000 hours at 125°C
- Low impedance at high frequency
- For electronic control unit and other high temperature applications
- Complied to the RoHS directive

**IZI** Low Impedance      **S** Solvent Proof

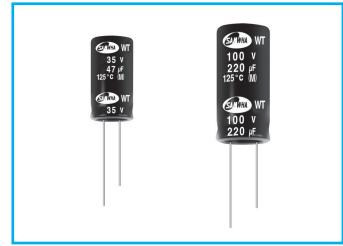

**RB** → **WT**  
Long life  
Low Imp.

Item	Characteristics																											
Operating temperature range	-40 ~ +125°C																											
Leakage Current max.	$I = 0.03CV$ or $3\mu A$ whichever is greater (after 2 minutes)																											
Capacitance Tolerance	$\pm 20\%$ at 120Hz, 20°C																											
Dissipation Factor max. (at 120Hz, 20°C)	Capacitance > 1000 $\mu F$ : $\tan\delta$ increases by 0.02 for each 1000 $\mu F$ from below value.																											
	<table border="1"> <thead> <tr> <th>WV</th> <th>6.3</th> <th>10</th> <th>16</th> <th>25</th> <th>35</th> <th>50</th> <th>63</th> <th>100</th> </tr> </thead> <tbody> <tr> <td><math>\tan\delta</math></td> <td>0.22</td> <td>0.20</td> <td>0.16</td> <td>0.14</td> <td>0.12</td> <td>0.10</td> <td>0.10</td> <td>0.08</td> </tr> </tbody> </table>	WV	6.3	10	16	25	35	50	63	100	$\tan\delta$	0.22	0.20	0.16	0.14	0.12	0.10	0.10	0.08									
WV	6.3	10	16	25	35	50	63	100																				
$\tan\delta$	0.22	0.20	0.16	0.14	0.12	0.10	0.10	0.08																				
Low temperature characteristics (Impedance ratio at 120Hz)	<table border="1"> <thead> <tr> <th>WV</th> <th>6.3</th> <th>10</th> <th>16</th> <th>25</th> <th>35</th> <th>50</th> <th>63</th> <th>100</th> </tr> </thead> <tbody> <tr> <td>Z-25°C/Z+20°C</td> <td>3</td> <td>3</td> <td>3</td> <td>2</td> <td>2</td> <td>2</td> <td>2</td> <td>2</td> </tr> <tr> <td>Z-40°C/Z+20°C</td> <td>6</td> <td>6</td> <td>4</td> <td>3</td> <td>3</td> <td>3</td> <td>3</td> <td>3</td> </tr> </tbody> </table>	WV	6.3	10	16	25	35	50	63	100	Z-25°C/Z+20°C	3	3	3	2	2	2	2	2	Z-40°C/Z+20°C	6	6	4	3	3	3	3	3
	WV	6.3	10	16	25	35	50	63	100																			
	Z-25°C/Z+20°C	3	3	3	2	2	2	2	2																			
Z-40°C/Z+20°C	6	6	4	3	3	3	3	3																				
Load life (after application of the rated voltage for 5000 hours at 125°C)	<table border="1"> <tbody> <tr> <td>Capacitance change</td> <td colspan="3">Within <math>\pm 30\%</math> of initial value</td> </tr> <tr> <td><math>\tan\delta</math></td> <td colspan="3">Less than 300% of the specified value</td> </tr> <tr> <td>Leakage current</td> <td colspan="3">Less than specified value</td> </tr> <tr> <td><math>\varnothing D</math></td> <td><math>\varnothing D = 5, 6.3</math></td> <td><math>\varnothing D = 8</math></td> <td><math>\varnothing D \geq 10</math></td> </tr> <tr> <td>Life time</td> <td>2000 hours</td> <td>3000 hours</td> <td>5000 hours</td> </tr> </tbody> </table>	Capacitance change	Within $\pm 30\%$ of initial value			$\tan\delta$	Less than 300% of the specified value			Leakage current	Less than specified value			$\varnothing D$	$\varnothing D = 5, 6.3$	$\varnothing D = 8$	$\varnothing D \geq 10$	Life time	2000 hours	3000 hours	5000 hours							
Capacitance change	Within $\pm 30\%$ of initial value																											
$\tan\delta$	Less than 300% of the specified value																											
Leakage current	Less than specified value																											
$\varnothing D$	$\varnothing D = 5, 6.3$	$\varnothing D = 8$	$\varnothing D \geq 10$																									
Life time	2000 hours	3000 hours	5000 hours																									
Shelf life (at 125°C)	After 1000 hours no load test, leakage current, capacitance and $\tan\delta$ are same as load life value. The measurement shall be performed at 20°C by the KS C IEC 60384 - 4																											

## DRAWING

Unit : mm

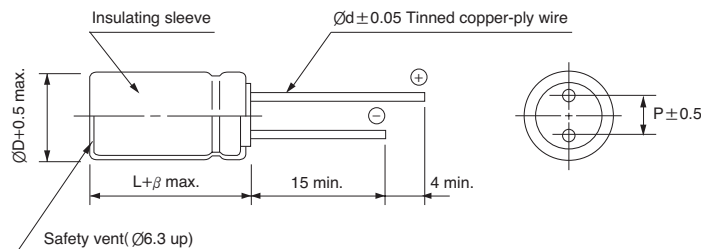

$\varnothing D$	5	6.3	8	10	12.5	16
P	2.0	2.5	3.5	5.0	5.0	7.5
$\varnothing d$	0.5	0.5	0.6	0.6	0.6	0.8
$\beta$	1.5		2.0			

## FREQUENCY COEFFICIENT OF PERMISSIBLE RIPPLE CURRENT

$\mu F$ \ Frequency	120Hz	1kHz	10kHz	50kHz	100kHz $\leq$
~ 33	0.20	0.50	0.80	0.90	1.00
47 ~ 100	0.25	0.60	0.90	0.95	1.00
150 ~ 220	0.35	0.70	0.92	0.96	1.00
330 ~ 680	0.45	0.75	0.95	0.97	1.00
1000 ~ 1500	0.50	0.80	0.96	0.98	1.00
2200 ~	0.55	0.85	0.98	0.99	1.00

## WT series

### ● DIMENSIONS & MAXIMUM PERMISSIBLE RIPPLE CURRENT

WV Item μF	6.3			10			16			25		
	∅D×L (mm)	Impedance (Ω)max. 20°C 100kHz	Ripple current (mA rms) 125°C 100kHz	∅D×L (mm)	Impedance (Ω)max. 20°C 100kHz	Ripple current (mA rms) 125°C 100kHz	∅D×L (mm)	Impedance (Ω)max. 20°C 100kHz	Ripple current (mA rms) 125°C 100kHz	∅D×L (mm)	Impedance (Ω)max. 20°C 100kHz	Ripple current (mA rms) 125°C 100kHz
47										5×11	0.80	250
68				5×11	0.80	250	5×11	0.80	250	6.3×11	0.34	405
100	5×11	0.80	250	6.3×11	0.34	405	6.3×11	0.34	405	6.3×11	0.34	405
150	6.3×11	0.34	405	6.3×11	0.34	405	6.3×11	0.34	405	8×11.5	0.28	760
220	6.3×11	0.34	405	8×11.5	0.30	760	8×11.5	0.28	760	10×12.5	0.14	1030
330	8×11.5	0.28	760	8×11.5	0.28	760	10×12.5	0.14	1030	10×16	0.10	1430
470	10×12.5	0.14	1030	10×12.5	0.14	1030	10×16	0.10	1430	10×20	0.08	1500
680	10×16	0.10	1430	10×16	0.10	1430	10×20	0.06	1500	12.5×20	0.06	1720
1000	10×20	0.06	1500	10×20	0.06	1500	12.5×20	0.06	1720	12.5×25	0.05	1900
1500	12.5×20	0.06	1620	12.5×20	0.06	1720	12.5×25	0.05	1900			
2200	12.5×20	0.06	1720	12.5×25	0.05	1900						
3300	12.5×25	0.05	1900									

WV Item μF	35			50			63			100		
	∅D×L (mm)	Impedance (Ω)max. 20°C 100kHz	Ripple current (mA rms) 125°C 100kHz	∅D×L (mm)	Impedance (Ω)max. 20°C 100kHz	Ripple current (mA rms) 125°C 100kHz	∅D×L (mm)	Impedance (Ω)max. 20°C 100kHz	Ripple current (mA rms) 125°C 100kHz	∅D×L (mm)	Impedance (Ω)max. 20°C 100kHz	Ripple current (mA rms) 125°C 100kHz
10												
22	5×11	0.80	250							10×12.5	0.80	480
33	6.3×11	0.34	405	8×11.5	0.70	300	8×11.5	1.50	150	10×12.5	0.80	480
47	6.3×11	0.34	405	8×11.5	0.70	440	10×12.5	0.59	530	10×16	0.65	630
68	8×11.5	0.28	760									
100	8×11.5	0.19	760	10×12.5	0.40	555	10×16	0.41	690	12.5×20	0.25	990
150	10×12.5	0.14	1030									
220	10×16	0.10	1430	10×20	0.15	930	12.5×20	0.16	1050	16×25	0.11	1500
330	12.5×20	0.06	1620	12.5×20	0.13	1330	12.5×25	0.12	1290	16×31.5	0.08	1790
470	12.5×20	0.06	1720	12.5×25	0.10	1650						
680	12.5×25	0.05	1900	16×31.5	0.05	2430						

# MINIATURE ALUMINUM ELECTROLYTIC CAPACITORS



130°C, Long Life, Low Impedance Series

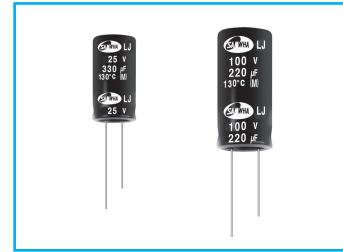

- For LED Lighting, LED Display
- High reliability withstanding 4000 hours load life at 130°C
- Complied to the RoHS directive

Item	Characteristics																														
Operating temperature range	-40 ~ +130°C(10 ~ 100WV), -25 ~ +130°C(200, 400WV)																														
Leakage current max.	<table border="1"> <tr> <th>WV ≤ 100</th> <th>WV &gt; 100</th> </tr> <tr> <td>I = 0.01CV or 3μA whichever is greater (after 2 min.) I = 0.03CV or 4μA whichever is greater (after 1 min.)</td> <td>I = 0.02CV + 15μA (after 5 min.)</td> </tr> </table>	WV ≤ 100	WV > 100	I = 0.01CV or 3μA whichever is greater (after 2 min.) I = 0.03CV or 4μA whichever is greater (after 1 min.)	I = 0.02CV + 15μA (after 5 min.)																										
	WV ≤ 100	WV > 100																													
I = 0.01CV or 3μA whichever is greater (after 2 min.) I = 0.03CV or 4μA whichever is greater (after 1 min.)	I = 0.02CV + 15μA (after 5 min.)																														
Capacitance tolerance	±20% at 120Hz, 20°C																														
Dissipation factor max. (at 120Hz, 20°C)	Capacitance > 1000μF : tanδ increases by 0.02 for each 1000μF from below value.																														
	<table border="1"> <tr> <th>WV</th> <td>10</td> <td>16</td> <td>25</td> <td>35</td> <td>50</td> <td>63</td> <td>100</td> <td>200</td> <td>400</td> </tr> <tr> <th>tanδ</th> <td>0.19</td> <td>0.16</td> <td>0.14</td> <td>0.12</td> <td>0.1</td> <td>0.09</td> <td>0.08</td> <td>0.15</td> <td>0.2</td> </tr> </table>	WV	10	16	25	35	50	63	100	200	400	tanδ	0.19	0.16	0.14	0.12	0.1	0.09	0.08	0.15	0.2										
WV	10	16	25	35	50	63	100	200	400																						
tanδ	0.19	0.16	0.14	0.12	0.1	0.09	0.08	0.15	0.2																						
Low temperature characteristics (Impedance ratio at 120Hz)	<table border="1"> <tr> <th>WV</th> <td>10</td> <td>16</td> <td>25</td> <td>35</td> <td>50</td> <td>63</td> <td>100</td> <td>200</td> <td>400</td> </tr> <tr> <th>Z-25°C/Z+20°C</th> <td>3</td> <td>2</td> <td>2</td> <td>2</td> <td>2</td> <td>2</td> <td>2</td> <td>3</td> <td>6</td> </tr> <tr> <th>Z-40°C/Z+20°C</th> <td>6</td> <td>4</td> <td>3</td> <td>3</td> <td>3</td> <td>3</td> <td>3</td> <td>-</td> <td>-</td> </tr> </table>	WV	10	16	25	35	50	63	100	200	400	Z-25°C/Z+20°C	3	2	2	2	2	2	2	3	6	Z-40°C/Z+20°C	6	4	3	3	3	3	3	-	-
	WV	10	16	25	35	50	63	100	200	400																					
	Z-25°C/Z+20°C	3	2	2	2	2	2	2	3	6																					
Z-40°C/Z+20°C	6	4	3	3	3	3	3	-	-																						
Load life (after application of the rated voltage for 4000 hours at 130°C)	Rated voltage (Vdc)	10 ~ 100WV	200, 400WV																												
	Capacitance change	Within ±30% of initial value	Within ±20% of initial value																												
	tanδ	Within ±300% of initial value	Within ±200% of initial value																												
	Leakage current	Less than specified value																													
		<table border="1"> <tr> <th rowspan="2">∅D</th> <th colspan="2">Life time(hrs)</th> </tr> <tr> <th>~100V</th> <th>200, 400V</th> </tr> <tr> <td>∅D = 6.3</td> <td>1,000</td> <td>-</td> </tr> <tr> <td>∅D = 8,10</td> <td>2,000</td> <td>3,000</td> </tr> <tr> <td>∅D ≥ 12.5</td> <td>4,000</td> <td>-</td> </tr> </table>			∅D	Life time(hrs)		~100V	200, 400V	∅D = 6.3	1,000	-	∅D = 8,10	2,000	3,000	∅D ≥ 12.5	4,000	-													
∅D	Life time(hrs)																														
	~100V	200, 400V																													
∅D = 6.3	1,000	-																													
∅D = 8,10	2,000	3,000																													
∅D ≥ 12.5	4,000	-																													
Shelf life (at 130°C)	After 1000 hours no load test, leakage current, capacitance and tanδ are same as load life value. The measurement shall be performed at 20°C by the KS C IEC 60384 - 4																														

## ● DRAWING

Unit : mm

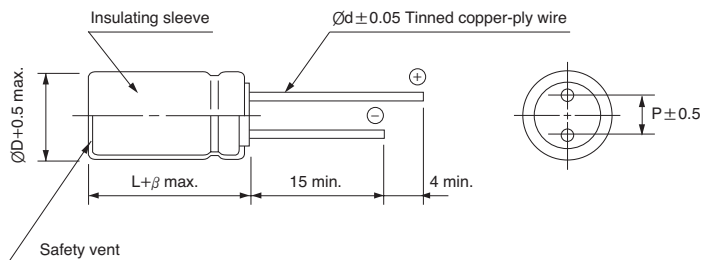

∅D	8	10	12.5	16	18
P	3.5	5.0	5.0	7.5	7.5
∅d	0.6	0.6	0.6	0.8	0.8
β	1.5	2.0			

## ● FREQUENCY COEFFICIENT OF PERMISSIBLE RIPPLE CURRENT

WV	μF	Frequency					
		120Hz	1kHz	10kHz	50kHz	100kHz ≤	
10~100	~ 4.7	0.42	0.60	0.80	0.90	1.00	
	10 ~ 33	0.55	0.75	0.90	0.95	1.00	
	47 ~ 330	0.70	0.85	0.95	0.98	1.00	
	470 ~ 1500	0.75	0.90	0.98	1.00	1.00	
	2200 ~	0.80	0.95	1.00	1.00	1.00	
200, 400	~ 5.6	0.20	0.40	0.80	0.90	1.00	
	6.8 ~ 15	0.30	0.60	0.90	0.95	1.00	
	22 ~	0.50	0.80	0.90	0.95	1.00	

**LJ** series

● DIMENSIONS & MAXIMUM PERMISSIBLE RIPPLE CURRENT

WV Item μF	10			16			25			35			50		
	∅D×L (mm)	IMP. (Ω)max. 20°C 100kHz	Ripple current (mA rms) 130°C 100kHz	∅D×L (mm)	IMP. (Ω)max. 20°C 100kHz	Ripple current (mA rms) 130°C 100kHz	∅D×L (mm)	IMP. (Ω)max. 20°C 100kHz	Ripple current (mA rms) 130°C 100kHz	∅D×L (mm)	IMP. (Ω)max. 20°C 100kHz	Ripple current (mA rms) 130°C 100kHz	∅D×L (mm)	IMP. (Ω)max. 20°C 100kHz	Ripple current (mA rms) 130°C 100kHz
4.7													8 × 11.5	1.000	100
10													8 × 11.5	0.800	200
22													8 × 11.5	0.800	260
33													8 × 11.5	0.600	300
47													8 × 11.5	0.600	300
100										8 × 11.5	0.220	360	10 × 12.5	0.180	520
220							8 × 11.5	0.220	360	10 × 12.5	0.150	620	10 × 20	0.082	890
330	8 × 11.5	0.220	360	8 × 11.5	0.220	360	10 × 12.5	0.150	620	10 × 16	0.100	800	12.5 × 20	0.065	1000
470	10 × 12.5	0.150	620	10 × 12.5	0.150	620	10 × 16	0.100	800	10 × 20	0.073	960	12.5 × 25	0.051	1200
1000	10 × 20	0.070	960	10 × 20	0.070	960	12.5 × 20	0.060	1100	12.5 × 25	0.040	1430	16 × 31.5	0.037	2180
2200	12.5 × 25	0.040	1430	12.5 × 25	0.040	1430	16 × 31.5	0.034	2300	16 × 35.5	0.031	2550	18 × 40	0.029	2800
3300	16 × 25	0.038	1900	16 × 31.5	0.034	2300	16 × 35.5	0.031	2550	18 × 35.5	0.028	2800			
4700	16 × 31.5	0.034	2300	16 × 35.5	0.031	2550									

WV Item μF	63			100			200		400	
	∅D×L (mm)	IMP. (Ω)max. 20°C 100kHz	Ripple current (mA rms) 130°C 100kHz	∅D×L (mm)	IMP. (Ω)max. 20°C 100kHz	Ripple current (mA rms) 130°C 100kHz	∅D×L (mm)	Ripple current (mA rms) 130°C 100kHz	∅D×L (mm)	Ripple current (mA rms) 130°C 100kHz
1.0									8 × 11.5	65
1.5									8 × 11.5	75
									8 × 15	80
1.8									8 × 11.5	75
									8 × 15	85
2.2									8 × 11.5	75
									8 × 15	90
									8 × 20	110
2.7									8 × 15	95
									8 × 20	115
3.3									8 × 20	120
									8 × 20	120
4.7				8 × 11.5	1.300	100	8 × 11.5	120	10 × 16	125
									8 × 20	120
5.6							8 × 11.5	130	10 × 16	130
							8 × 15	180	10 × 20	145
6.8							8 × 11.5	130	10 × 20	150
							8 × 15	180		
10				8 × 11.5	1.000	200	8 × 15	200		
							8 × 20	240		
15							8 × 15	200		
							8 × 20	240		
22				8 × 11.5	1.000	220	8 × 20	240		
							10 × 16	240		
33	8 × 11.5	0.500	250	10 × 12.5	0.670	260	10 × 20	320		
47	10 × 12.5	0.370	400	10 × 16	0.330	330				
100	10 × 16	0.300	450	12.5 × 20	0.170	670				
220	12.5 × 20	0.120	820	16 × 25	0.130	1100				
330	12.5 × 25	0.102	1000	16 × 31.5	0.100	1300				
470	16 × 25	0.089	1500	18 × 31.5	0.092	1600				
1000	16 × 31.5	0.076	1850							
1500	18 × 40	0.063	2350							



# MINIATURE ALUMINUM ELECTROLYTIC CAPACITORS

Upgrade

# BK

For PSU, High Temperature Series

- High reliability withstanding 5000 hours load life at 125°C
- Suitable for compact energy saving lamp
- Complied to the RoHS directive

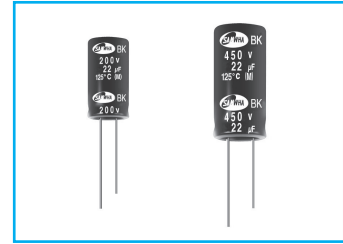

Item	Characteristics						
Operating temperature range	-40 ~ +125°C						
Leakage current max.	$I = 0.03CV + 15\mu A$ ( $CV \leq 1000$ ), $I = 0.02CV + 25\mu A$ ( $CV > 1000$ ) (after 5 minutes)						
Capacitance tolerance	$\pm 20\%$ at 120Hz, 20°C						
Dissipation factor max. (at 120Hz, 20°C)	WV	160	200	250	350	400	450
	tan $\delta$	0.15	0.15	0.15	0.20	0.24	0.24
Low temperature characteristics (Impedance ratio at 120Hz)	WV	160	200	250	350	400	450
	Z-25°C/Z+20°C	3	3	3	3	6	6
	Z-40°C/Z+20°C	4	4	4	6	6	6
Load life	After an application of DC bias voltage plus the rated AC ripple current for 5000 hours at 125°C. The measurement shall meet the following limits. The DC voltage plus the peak AC voltage combined must not exceed the rated voltage.						
	Leakage current	Less than specified value					
	Capacitance change	Within $\pm 20\%$ of initial value					
Shelf life (at 125°C)	After 1000 hours no load test, leakage current, capacitance and tan $\delta$ are same as load life value. The measurement shall be performed at 20°C by the KS C IEC 60384 - 4						

## ● DRAWING

Unit : mm

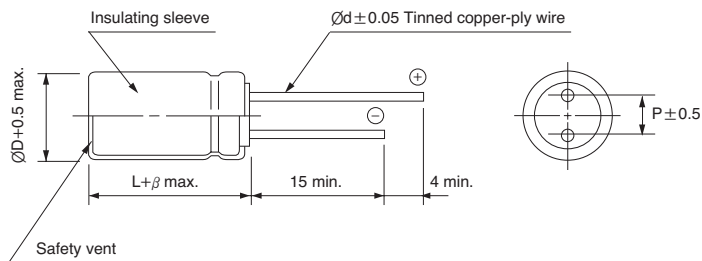

ØD	10	12.5	16	18
P	5.0	5.0	7.5	7.5
Ød	0.6	0.6	0.8	0.8
β	2.0			

## ● FREQUENCY COEFFICIENT OF PERMISSIBLE RIPPLE CURRENT

Frequency	60Hz	120Hz	1kHz	10kHz	50kHz	100kHz ≤
Coefficient	0.30	0.40	0.70	0.90	0.95	1.00

## BK series

### ● DIMENSIONS & MAXIMUM PERMISSIBLE RIPPLE CURRENT

$\mu\text{F}$ \diagdown WV	160		200		250	
3.3					10 × 12.5	135
4.7	10 × 12.5	135	10 × 12.5	150	10 × 12.5	150
					10 × 16	180
10	10 × 12.5	165	10 × 12.5	195	10 × 16	210
					10 × 16	240
22	10 × 20	420	10 × 20	420	12.5 × 20	450
					10 × 20	580
33	12.5 × 20	600	12.5 × 20	600	12.5 × 25	675
			10 × 20	580	12.5 × 20	650
47	12.5 × 20	780	12.5 × 20	780	12.5 × 25	900
56	12.5 × 20	900	12.5 × 20	1220	16 × 20	1100
68	12.5 × 20	1100	12.5 × 25	1250	16 × 25	1200
75	12.5 × 25	1220	12.5 × 25	1300	18 × 20	1400
82	12.5 × 25	1300	12.5 × 25	1400	18 × 20	1730
					16 × 25	1730
100	16 × 20	1340	16 × 20	1500	16 × 25	1850
120	16 × 20	1500	18 × 20	1610	18 × 25	1910
150	16 × 25	1610	16 × 25	1730		
180	18 × 25	1730	18 × 25	1850		

↑ Ripple current (mA rms) at 125°C, 100kHz  
 ↑ Case size  $\varnothing D \times L$  (mm)

$\mu\text{F}$ \diagdown WV	350		400		450	
2.2	10 × 12.5	135	10 × 12.5	135		
3.3	10 × 16	180	10 × 16	150		
4.7	10 × 16	195	10 × 20	255		
	10 × 20	255				
10	12.5 × 20	375	12.5 × 20	375	12.5 × 20	232
18	12.5 × 20	438	12.5 × 20	650	16 × 20	320
22	12.5 × 20	500	12.5 × 25	700	16 × 25	415
27	12.5 × 25	575	12.5 × 25	775	16 × 25	450
33	12.5 × 25	650	16 × 20	888	16 × 25	480
	16 × 20	900				
39	16 × 20	950	16 × 25	1013	16 × 31.5	514
47	16 × 25	1100	16 × 25	1125	16 × 31.5	548
			18 × 20	1088	18 × 25	548
56	16 × 25	1400	18 × 25	1375	16 × 35.5	650
	18 × 20	1400			18 × 31.5	650
68	18 × 25	1500	16 × 31.5	1413	18 × 35.5	720
75	18 × 25	1730	16 × 35.5	1520	18 × 35.5	750
82			16 × 35.5	1613	18 × 40	880
			16 × 40	1688		
			18 × 31.5	1600		
100			18 × 35.5	1665		

# MINIATURE ALUMINUM ELECTROLYTIC CAPACITORS

New

# BQ

For PSU, Long Life, High Temperature Series

- High reliability withstanding 5000 hours load life at 125°C
- Suitable for compact energy saving lamp
- Complied to the RoHS directive

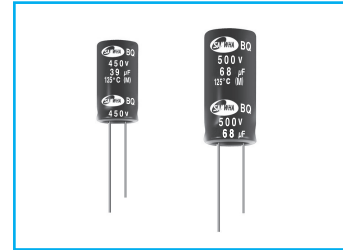

Item	Characteristics		
Operating temperature range	-40 ~ +125°C		
Leakage current max.	I = 0.03CV+15μA (CV ≤ 1000), I = 0.02CV+25μA (CV > 1000) (after 5 minutes)		
Capacitance tolerance	±20% at 120Hz, 20°C		
Dissipation factor max. (at 120Hz, 20°C)	WV	450	500
	tanδ	0.24	0.25
Low temperature characteristics (Impedance ratio at 120Hz)	WV	450	500
	Z-25°C/Z+20°C	6	6
	Z-40°C/Z+20°C	6	6
Load life	After an application of DC bias voltage plus the rated AC ripple current for 5000 hours at 125°C. The measurement shall meet the following limits. The DC voltage plus the peak AC voltage combined must not exceed the rated voltage.		
	Leakage current	Less than specified value	
	Capacitance change	Within ±20% of initial value	
	tanδ	Less than 200% of specified value	
Shelf life (at 125°C)	After 1000 hours no load test, leakage current, capacitance and tanδ are same as load life value. The measurement shall be performed at 20°C by the KS C IEC 60384 - 4		

● DRAWING (See page 162)

Unit : mm

● DIMENSIONS & MAXIMUM PERMISSIBLE RIPPLE CURRENT

μF	WV	450		500	
		Case size	Ripple current	Case size	Ripple current
22	16 × 20	690	16 × 20	675	
27				16 × 25	800
33	16 × 20	860	18 × 20	788	
39			18 × 25	900	
47	16 × 25	1000	16 × 31.5	1013	
	18 × 25		18 × 25	1000	
56	16 × 31.5	1163	16 × 35.5	1150	
	18 × 25		18 × 31.5	1150	
68	16 × 35.5	1325	16 × 40	1313	
	18 × 31.5		18 × 35.5	1313	
82	16 × 40	1513	18 × 40	1500	
	18 × 35.5				1650
100	18 × 40	1665	18 × 45	1700	

↑ Ripple current (mA rms) at 105°C, 100kHz  
 ↑ Case size ØD × L (mm)

● FREQUENCY COEFFICIENT OF PERMISSIBLE RIPPLE CURRENT

Frequency	60Hz	120Hz	1kHz	10kHz	50kHz	100kHz ≤
Coefficient	0.30	0.40	0.70	0.90	0.95	1.00

# MINIATURE ALUMINUM ELECTROLYTIC CAPACITORS



## MW High Ripple Current Series

- Load life of 5000 hours at 105°C
- Voltage range 25 ~ 500V
- Complied to the RoHS directive

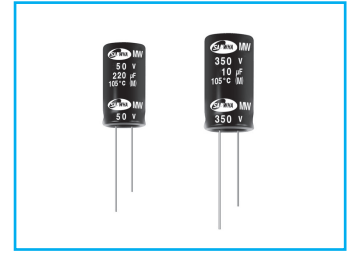

Item	Characteristics											
Operating temperature range	WV		25 ~ 450					500				
	Temperature range		-40 ~ +105°C					-25 ~ +105°C				
Leakage current max.	WV ≤ 100						WV > 100					
	I = 0.01CV or 3μA whichever is greater (after 2 min.) I = 0.03CV or 4μA whichever is greater (after 1 min.)						I = 0.02CV + 15μA (after 5 min.)					
Capacitance tolerance	±20% at 120Hz, 20°C											
Dissipation factor max. (at 120Hz, 20°C)	WV	25	35	50	160	200	250	350	400	450	500	
	tanδ	0.14	0.12	0.10	0.15	0.15	0.15	0.20	0.24	0.24	0.24	
Low temperature characteristics (Impedance ratio at 120Hz)	WV	25	35	50	160	200	250	350	400	450	500	
	Z-25°C/Z+20°C	2	2	2	3	3	4	4	6	6	6	
	Z-40°C/Z+20°C	3	3	3	4	4	4	8	10	10	-	
Load life	After an application of DC bias voltage plus the rated AC ripple current for 5000 hours at 105°C. The measurement shall meet the following limits. The DC voltage plus the peak AC voltage combined must not exceed the rated voltage.											
	Rated voltage (Vdc)	25 ~ 50					160 ~ 500					
	Capacitance change	Within ±25% of initial value					Within ±20% of initial value					
	tanδ	Less than 200% of specified value										
	Leakage current	Less than specified value										
Shelf life (at 105°C)	After 1000 hours no load test, leakage current, capacitance and tanδ are same as load life value. The measurement shall be performed at 20°C by the KS C IEC 60384 - 4											

### ● DRAWING

Unit : mm

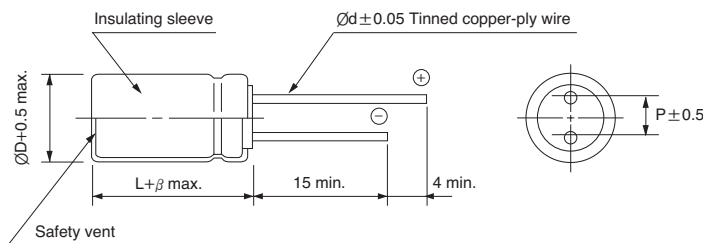

ØD	10
P	5.0
Ød	0.6
β	1.0

Vdc	Cap.(μF)	ØD×L (mm)	Rated ripple current (mA rms / 105°C)		
			120Hz	50kHz	100kHz
25	470	10 × 12.5	680	1987	2092
35	330		680	1862	1960
50	220		495	1568	1650
160	27		240	608	640
200	22		220	565	595
250	6.8		123	323	340
250	15		174	485	510
350	10		145	394	415
400	8.2		132	342	360
450	3.3		92	292	307
500	4.7		88	230	250

# MINIATURE ALUMINUM ELECTROLYTIC CAPACITORS



For Airbag application Series

- High capacitance, low impedance, and good low temperature behavior
- High reliability withstanding 5000 hours load life at 105°C
- Complied to the RoHS directive

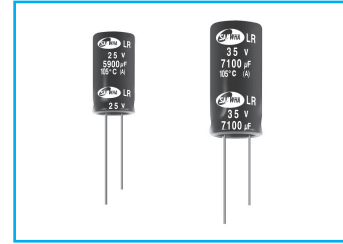

Item	Characteristics		
Operating temperature range	-55 ~ +105°C		
Leakage current max.	I = 0.01CV or 3µA whichever is greater (after 2 minutes) I = 0.03CV or 4µA whichever is greater (after 1 minutes)		
Capacitance tolerance	0 to + 30% at 120Hz, 20°C		
Dissipation factor max. (at 120Hz, 20°C)	Capacitance > 1000µF : tanδ increases by 0.02 for each 1000µF from below value.		
	WV	25	35
	tanδ	0.20	0.14
Low temperature characteristics (Impedance ratio at 120Hz)	WV	25	35
	Z-55°C/Z+20°C	3	3
Load life	After an application of DC bias voltage plus the rated AC ripple current for 5000 hours at 105°C. The measurement shall meet the following limits. The DC voltage plus the peak AC voltage combined must not exceed the rated voltage.		
	Leakage current	Less than specified value	
	Capacitance change	Within ±30% of initial value	
	tanδ	Less than 300% of specified value	
Shelf life (at 105°C)	After 1000 hours no load test, leakage current, capacitance and tanδ are same as load life value. The measurement shall be performed at 20°C by the KS C IEC 60384 - 4		

## ● DRAWING

Unit : mm

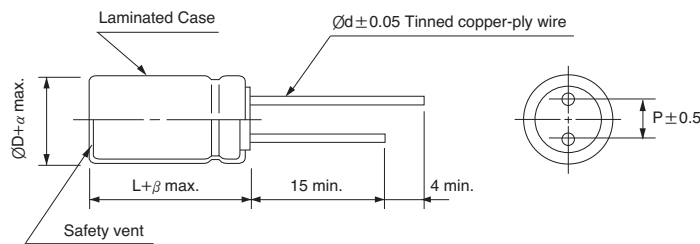

ØD	16	18
P	7.5	7.5
Ød	0.8	0.8
β	2.0	

## ● DIMENSIONS & MAXIMUM PERMISSIBLE RIPPLE CURRENT

µF	WV	25		µF	35		
	4200	16 × 20	0.033		2250	2500	16 × 20
5300	18 × 20	0.029	2500	3100	18 × 20	0.029	2500
5900	16 × 25	0.024	2600	3500	16 × 25	0.024	2600
7500	18 × 25	0.022	2800	4500	18 × 25	0.022	2800
8000	16 × 31.5	0.021	3200	4700	16 × 31.5	0.021	3200
9500	16 × 35.5	0.019	3500	5600	16 × 35.5	0.019	3500
10000	18 × 31.5	0.019	3500	6000	18 × 31.5	0.019	3500
11000	16 × 40	0.017	3800	6600	16 × 40	0.017	3800
11000	18 × 35.5	0.017	3700	7100	18 × 35.5	0.017	3700
14000	18 × 40	0.015	4000	8400	18 × 40	0.015	4000

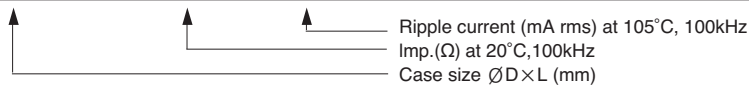

## ● FREQUENCY COEFFICIENT OF PERMISSIBLE RIPPLE CURRENT

µF	Frequency	120Hz	1kHz	10kHz	50kHz	100kHz ≤
	2500 ~ 3500		0.75	0.90	0.95	0.97
4200 ~ 14000		0.85	0.95	0.98	0.99	1.00

## VP 135°C, Long Life, Low Impedance Series

- Applied Laminated case series
- Suited for automobile applications
- Complied to the RoHS directive
- AEC-Q200 compliant. Please contact us for details

RB → **VP**  
Long Life  
High Temp.

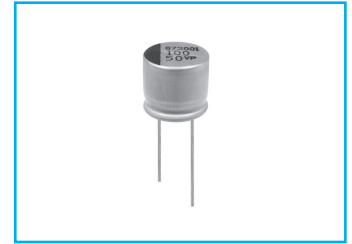

Item	Characteristics				
Operating temperature range	-40 ~ +135°C				
Leakage current max.	I = 0.01CV or 3μA whichever is greater (after 2 minutes)				
Capacitance tolerance	±20% at 120Hz, 20°C				
Dissipation factor max. (at 120Hz, 20°C)	Capacitance > 1000μF : tanδ increases by 0.02 for each 1000μF from below value.				
	WV	10	16	25	35
Low temperature characteristics (Impedance ratio at 120Hz)	tanδ	0.20	0.16	0.14	0.12
	WV	10	16	25	35
	Z-25°C/Z+20°C	3	2	2	2
Load life (after application of the rated voltage for 3000 hours at 135°C)	Z-40°C/Z+20°C	6	4	3	3
	Leakage current	Less than specified value			
	Capacitance change	Within ±30% of initial value			
Shelf life (at 135°C)	tanδ	Less than 300% of specified value			
	After 1000 hours no load test, leakage current, capacitance and tanδ are same as load life value. The measurement shall be performed at 20°C by the KS C IEC 60384 - 4				

### DRAWING

Unit : mm

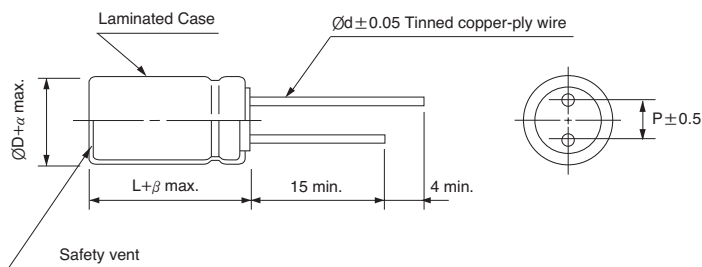

ØD	10	12.5	16	18
P	5.0	5.0	7.5	7.5
Ød	0.6	0.6	0.8	0.8
α	0.5			
β	2.0			

(Ø10)

(Ø12.5≤)

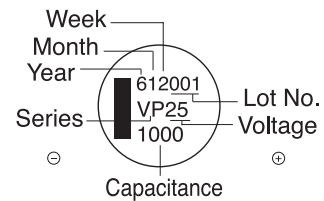
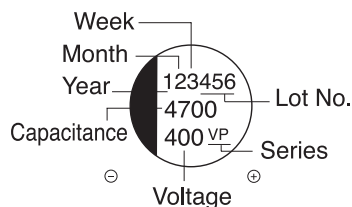

### FREQUENCY COEFFICIENT OF PERMISSIBLE RIPPLE CURRENT

μF \ Frequency	120Hz	1kHz	10kHz	50kHz	100kHz ≤
~ 330	0.50	0.85	0.95	0.97	1.00
470 ~ 1500	0.55	0.90	0.98	0.99	1.00
2200 ~	0.60	0.95	0.98	0.99	1.00

# MINIATURE ALUMINUM ELECTROLYTIC CAPACITORS

**VP** series

● DIMENSIONS & MAXIMUM PERMISSIBLE RIPPLE CURRENT

WV Item μF	10			16		
	∅D × L (mm)	Impedance (Ω)max. 20°C 100kHz	Ripple current (mA rms) 135°C 100kHz	∅D × L (mm)	Impedance (Ω)max. 20°C 100kHz	Ripple current (mA rms) 135°C 100kHz
470	10 × 12.5	0.15	690	10 × 12.5	0.10	960
1000	10 × 20	0.07	1005	10 × 20	0.060	1150
2200	12.5 × 25	0.050	1280	12.5 × 25	0.060	1430
3300	12.5 × 30	0.050	1900	12.5 × 30	0.050	2300
4700	16 × 25	0.035	2200	16 × 25	0.035	2440
5600	18 × 25	0.030	3300	18 × 25	0.030	3660
6800	18 × 31.5	0.028	3600	18 × 31.5	0.028	4000

WV Item μF	25			35		
	∅D × L (mm)	Impedance (Ω)max. 20°C 100kHz	Ripple current (mA rms) 135°C 100kHz	∅D × L (mm)	Impedance (Ω)max. 20°C 100kHz	Ripple current (mA rms) 135°C 100kHz
220				10 × 12.5	0.15	620
330				10 × 16	0.10	800
470	10 × 20	0.10	1130	10 × 20	0.070	960
1000	12.5 × 25	0.060	1800	12.5 × 30	0.040	1430
1500	12.5 × 30	0.055	2000	16 × 25	0.038	2100
2200	12.5 × 30	0.050	2300	18 × 25	0.035	2500
	16 × 25	0.050	2200			
3300	18 × 25	0.045	3300	18 × 25	0.032	2700
				18 × 31.5	0.032	3800
3900	18 × 25	0.040	3400	18 × 25	0.032	2900
	18 × 31.5	0.040	3600	18 × 35.5	0.032	3900
4700	16 × 25	0.035	2870			
	18 × 31.5	0.040	3600			

## VQ 150°C, High Temperature Range Series

- Applied Laminated case series
- Suited for automobile applications
- Complied to the RoHS directive
- AEC-Q200 compliant. Please contact us for details

VP → VQ  
High Temp.

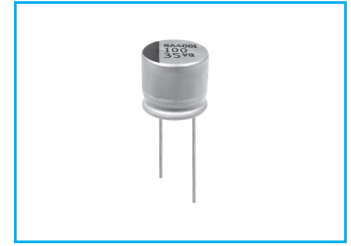

Item	Characteristics																											
Operating temperature range	-40 ~ +150°C																											
Leakage current max.	$I = 0.03CV$ or $4\mu A$ whichever is greater (after 1 minute)																											
Capacitance tolerance	$\pm 20\%$ at 120Hz, 20°C																											
Dissipation factor max. (at 120Hz, 20°C)	Capacitance > 1000 $\mu F$ : $\tan\delta$ increases by 0.02 for each 1000 $\mu F$ from below value.																											
	<table border="1"> <tr> <td>WV</td> <td>10</td> <td>16</td> <td>25</td> <td>35</td> <td>50</td> <td>63</td> <td>80</td> <td>100</td> </tr> <tr> <td><math>\tan\delta</math></td> <td>0.20</td> <td>0.16</td> <td>0.14</td> <td>0.12</td> <td>0.10</td> <td>0.10</td> <td>0.08</td> <td>0.08</td> </tr> </table>	WV	10	16	25	35	50	63	80	100	$\tan\delta$	0.20	0.16	0.14	0.12	0.10	0.10	0.08	0.08									
WV	10	16	25	35	50	63	80	100																				
$\tan\delta$	0.20	0.16	0.14	0.12	0.10	0.10	0.08	0.08																				
Low temperature characteristics (Impedance ratio at 120Hz)	<table border="1"> <tr> <td>WV</td> <td>10</td> <td>16</td> <td>25</td> <td>35</td> <td>50</td> <td>63</td> <td>80</td> <td>100</td> </tr> <tr> <td>Z-25°C/Z+20°C</td> <td>3</td> <td>2</td> <td>2</td> <td>2</td> <td>2</td> <td>2</td> <td>2</td> <td>2</td> </tr> <tr> <td>Z-40°C/Z+20°C</td> <td>4</td> <td>4</td> <td>4</td> <td>4</td> <td>4</td> <td>4</td> <td>4</td> <td>4</td> </tr> </table>	WV	10	16	25	35	50	63	80	100	Z-25°C/Z+20°C	3	2	2	2	2	2	2	2	Z-40°C/Z+20°C	4	4	4	4	4	4	4	4
	WV	10	16	25	35	50	63	80	100																			
	Z-25°C/Z+20°C	3	2	2	2	2	2	2	2																			
Z-40°C/Z+20°C	4	4	4	4	4	4	4	4																				
Load life (after application of the rated voltage for 1000 hours at 150°C)	<table border="1"> <tr> <td>Leakage current</td> <td>Less than specified value</td> </tr> <tr> <td>Capacitance change</td> <td>Within <math>\pm 30\%</math> of initial value</td> </tr> <tr> <td><math>\tan\delta</math></td> <td>Less than 300% of specified value</td> </tr> </table>	Leakage current	Less than specified value	Capacitance change	Within $\pm 30\%$ of initial value	$\tan\delta$	Less than 300% of specified value																					
Leakage current	Less than specified value																											
Capacitance change	Within $\pm 30\%$ of initial value																											
$\tan\delta$	Less than 300% of specified value																											
Shelf life (at 150°C)	After 1000 hours no load test, leakage current, capacitance and $\tan\delta$ are same as load life value. The measurement shall be performed at 20°C by the KS C IEC 60384 - 4																											

### DRAWING

Unit : mm

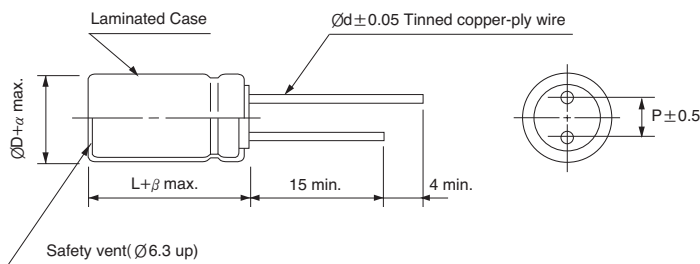

ØD	10	12.5	16	18
P	5.0	5.0	7.5	7.5
Ød	0.6	0.6	0.8	0.8
$\alpha$	0.5			
$\beta$	2.0			

(Ø10)

(Ø12.5)

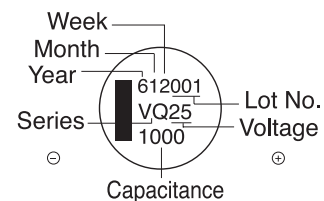
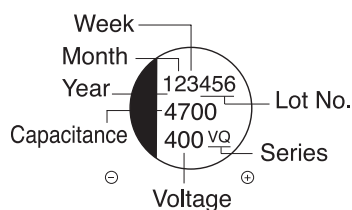

### FREQUENCY COEFFICIENT OF PERMISSIBLE RIPPLE CURRENT

CV	Frequency	120Hz	1kHz	50kHz	100kHz $\leq$
$1000 \leq CV$		0.67	0.91	0.95	1.00
$1000 > CV$		0.50	0.83	0.91	1.00



# MINIATURE ALUMINUM ELECTROLYTIC CAPACITORS

**VO** series

● DIMENSIONS & MAXIMUM PERMISSIBLE RIPPLE CURRENT

WV Item μF	10		16		25		35	
	ØD×L(mm)	Ripple current (mA rms) 150°C, 100kHz	ØD×L(mm)	Ripple current (mA rms) 150°C, 100kHz	ØD×L(mm)	Ripple current (mA rms) 150°C, 100kHz	ØD×L(mm)	Ripple current (mA rms) 150°C, 100kHz
82							10 × 12.5	620
100							10 × 16	660
220					10 × 16	660	12.5 × 20	700
330			10 × 16	660	12.5 × 20	760	12.5 × 25	840
470	10 × 12.5	660	10 × 20	760	12.5 × 25	840	12.5 × 30	1000
							16 × 25	1000
1000	10 × 20	760	12.5 × 25	840	16 × 25	1100	18 × 31.5	1700
2200	12.5 × 25	840	16 × 25	1100	18 × 31.5	1700		
3300	16 × 25	1100	18 × 31.5	1700				
4700	18 × 25	1700						
5600	18 × 31.5	1900						

WV Item μF	50		63		80		100	
	ØD×L(mm)	Ripple current (mA rms) 150°C, 100kHz	ØD×L(mm)	Ripple current (mA rms) 150°C, 100kHz	ØD×L(mm)	Ripple current (mA rms) 150°C, 100kHz	ØD×L(mm)	Ripple current (mA rms) 150°C, 100kHz
33							10 × 12.5	260
47					10 × 12.5	260	10 × 16	330
56			10 × 12.5	450	10 × 16	330	10 × 16	390
68			10 × 16	650	10 × 16	390	10 × 20	465
100	10 × 16	700	10 × 20	820	10 × 20	465	12.5 × 20	670
220	12.5 × 20	890	12.5 × 25	1000	12.5 × 25	670	12.5 × 30	1100
330	12.5 × 25	1000	12.5 × 30	1300			18 × 31.5	1500
470	12.5 × 30	1200	16 × 25	1500	18 × 25	1600	18 × 31.5	1750
560	16 × 25	1300	18 × 25	1650	18 × 31.5	1700		
680			18 × 31.5	1850	18 × 31.5	1900		

# MINIATURE ALUMINUM ELECTROLYTIC CAPACITORS



150°C, High Temperature Range Series

- Applied Laminated case series
- Suited for automobile applications
- Complied to the RoHS directive
- AEC-Q200 compliant. Please contact us for details

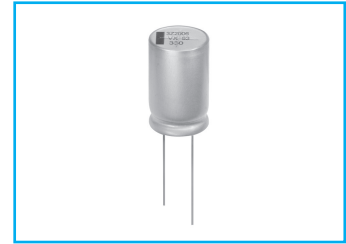

Item	Characteristics															
Operating temperature range	-40 ~ +150°C															
Leakage current max.	$I = 0.03CV$ or $4\mu A$ whichever is greater (after 1 minutes)															
Capacitance tolerance	$\pm 20\%$ at 120Hz, 20°C															
Dissipation factor max. (at 120Hz, 20°C)	Capacitance > 1000 $\mu F$ : $\tan\delta$ increases by 0.02 for each 1000 $\mu F$ from below value.															
	<table border="1"> <thead> <tr> <th>WV</th> <th>50</th> <th>63</th> <th>80</th> <th>100</th> </tr> </thead> <tbody> <tr> <td><math>\tan\delta</math></td> <td>0.10</td> <td>0.10</td> <td>0.08</td> <td>0.08</td> </tr> </tbody> </table>	WV	50	63	80	100	$\tan\delta$	0.10	0.10	0.08	0.08					
WV	50	63	80	100												
$\tan\delta$	0.10	0.10	0.08	0.08												
Low temperature characteristics (Impedance ratio at 120Hz)	<table border="1"> <thead> <tr> <th>WV</th> <th>50</th> <th>63</th> <th>80</th> <th>100</th> </tr> </thead> <tbody> <tr> <td>Z-25°C/Z+20°C</td> <td>2</td> <td>2</td> <td>2</td> <td>2</td> </tr> <tr> <td>Z-40°C/Z+20°C</td> <td>4</td> <td>4</td> <td>4</td> <td>4</td> </tr> </tbody> </table>	WV	50	63	80	100	Z-25°C/Z+20°C	2	2	2	2	Z-40°C/Z+20°C	4	4	4	4
	WV	50	63	80	100											
	Z-25°C/Z+20°C	2	2	2	2											
Z-40°C/Z+20°C	4	4	4	4												
Load life (after application of the rated voltage for 2000 hours at 150°C)	<table border="1"> <tbody> <tr> <td>Leakage current</td> <td>Less than specified value</td> </tr> <tr> <td>Capacitance change</td> <td>Within <math>\pm 30\%</math> of initial value</td> </tr> <tr> <td><math>\tan\delta</math></td> <td>Less than 300% of specified value</td> </tr> </tbody> </table>	Leakage current	Less than specified value	Capacitance change	Within $\pm 30\%$ of initial value	$\tan\delta$	Less than 300% of specified value									
Leakage current	Less than specified value															
Capacitance change	Within $\pm 30\%$ of initial value															
$\tan\delta$	Less than 300% of specified value															
Shelf life (at 150°C)	After 1000 hours no load test, leakage current, capacitance and $\tan\delta$ are same as load life value. The measurement shall be performed at 20°C by the KS C IEC 60384 - 4															

## ● DRAWING (See page 169)

Unit : mm

ØD	10	12.5	16	18
P	5.0	5.0	7.5	7.5
Ød	0.6	0.6	0.8	0.8
$\beta$	2.0			

## ● DIMENSIONS & MAXIMUM PERMISSIBLE RIPPLE CURRENT

$\mu F$ \ WV	50	63	80	100
68				12.5 × 20, 760
100			12.5 × 20, 820	12.5 × 25, 950
220		12.5 × 25, 1040	16 × 25, 1250	16 × 31.5, 1380
330	12.5 × 20, 770	16 × 25, 1170	16 × 31.5, 1480	18 × 31.5, 1430
470	12.5 × 25, 960	16 × 25, 1280	18 × 31.5, 1530	
560	16 × 25, 1080	16 × 31.5, 1520		
680	16 × 25, 1190	16 × 35.5, 1520		
1000	16 × 31.5, 1420			

↑ Ripple current (mA rms) at 150°C, 100kHz  
 ↑ Case size ØD×L (mm)

## ● FREQUENCY COEFFICIENT OF PERMISSIBLE RIPPLE CURRENT

$\mu F$ \ Frequency	120Hz	10kHz	50kHz	100kHz $\leq$
1000 $\leq$ CV	0.67	0.91	0.95	1.00
1000 > CV	0.50	0.83	0.91	1.00

MINIATURE TYPES

# MINIATURE ALUMINUM ELECTROLYTIC CAPACITORS

## NP Non-Polarized Series

- Standard non-polarized series
- Designed for use in circuits with reversing polarity
- Higher voltage ratings available up to 250V
- Load life of 2000 hours at 85°C
- Complied to the RoHS directive

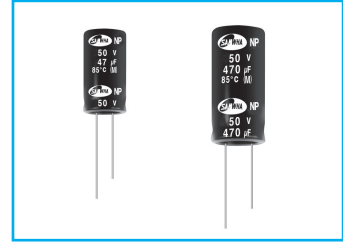
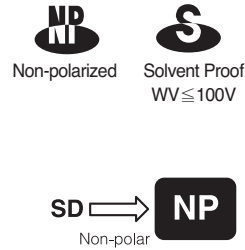

Item	Characteristics																							
Operating temperature range	-40 ~ +85°C																							
Leakage current max.	$I = 0.03CV$ or $3\mu A$ whichever is greater (after 5 minutes)																							
Capacitance tolerance	±20% at 120Hz, 20°C																							
Dissipation factor max. (at 120Hz, 20°C)	Capacitance > 1000 $\mu F$ : $\tan\delta$ increases by 0.02 for each 1000 $\mu F$ from below value.																							
	<table border="1"> <thead> <tr> <th>WV</th> <th>6.3</th> <th>10</th> <th>16</th> <th>25</th> <th>35</th> <th>50</th> <th>63</th> <th>80</th> <th>100</th> <th>160</th> <th>200,250</th> </tr> </thead> <tbody> <tr> <td><math>\tan\delta</math></td> <td>0.25</td> <td>0.23</td> <td>0.20</td> <td>0.15</td> <td>0.15</td> <td>0.12</td> <td>0.12</td> <td>0.12</td> <td>0.12</td> <td>0.15</td> <td>0.20</td> </tr> </tbody> </table>	WV	6.3	10	16	25	35	50	63	80	100	160	200,250	$\tan\delta$	0.25	0.23	0.20	0.15	0.15	0.12	0.12	0.12	0.12	0.15
WV	6.3	10	16	25	35	50	63	80	100	160	200,250													
$\tan\delta$	0.25	0.23	0.20	0.15	0.15	0.12	0.12	0.12	0.12	0.15	0.20													
Low temperature characteristics (Impedance ratio at 120Hz)	<table border="1"> <thead> <tr> <th>WV</th> <th>6.3</th> <th>10</th> <th>16</th> <th>25 ~ 100</th> <th>160 ~ 250</th> </tr> </thead> <tbody> <tr> <td>Z-25°C/Z+20°C</td> <td>4</td> <td>3</td> <td>2</td> <td>2</td> <td>3</td> </tr> <tr> <td>Z-40°C/Z+20°C</td> <td>10</td> <td>8</td> <td>6</td> <td>4</td> <td>5</td> </tr> </tbody> </table>	WV	6.3	10	16	25 ~ 100	160 ~ 250	Z-25°C/Z+20°C	4	3	2	2	3	Z-40°C/Z+20°C	10	8	6	4	5					
	WV	6.3	10	16	25 ~ 100	160 ~ 250																		
	Z-25°C/Z+20°C	4	3	2	2	3																		
Z-40°C/Z+20°C	10	8	6	4	5																			
Load life (after application of the rated voltage for 2000 hours at 85°C)	<table border="1"> <tbody> <tr> <td>Leakage current</td> <td>Less than specified value</td> </tr> <tr> <td>Capacitance change</td> <td>Within ±20% of initial value</td> </tr> <tr> <td><math>\tan\delta</math></td> <td>Less than 200% of specified value</td> </tr> <tr> <td>Test method</td> <td>Polarity reverse each 250 hours</td> </tr> </tbody> </table>	Leakage current	Less than specified value	Capacitance change	Within ±20% of initial value	$\tan\delta$	Less than 200% of specified value	Test method	Polarity reverse each 250 hours															
Leakage current	Less than specified value																							
Capacitance change	Within ±20% of initial value																							
$\tan\delta$	Less than 200% of specified value																							
Test method	Polarity reverse each 250 hours																							
Shelf life (at 85°C)	After 1000 hours no load test, leakage current, capacitance and $\tan\delta$ are same as load life value. The measurement shall be performed at 20°C by the KS C IEC 60384 - 4																							

### ● DRAWING

Unit : mm

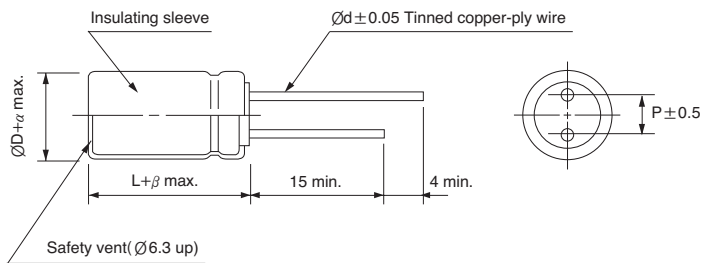

ØD	5	6.3	8	10	12.5	16	18	22
P	2.0	2.5	3.5	5.0	5.0	7.5	7.5	10.0
Ød	0.5	0.5	0.6	0.6	0.6	0.8	0.8	1.0
α	0.5							1.0
β	1.5		2.0			3.0		

### ● FREQUENCY COEFFICIENT OF PERMISSIBLE RIPPLE CURRENT

µF	Frequency	50Hz	120Hz	1kHz	10kHz ≤
~ 47		0.75	1.00	1.55	2.00
68 ~ 680		0.80	1.00	1.34	1.50
1000 ~		0.85	1.00	1.13	1.15

## NP series

### ● DIMENSIONS & MAXIMUM PERMISSIBLE RIPPLE CURRENT

WV μF	6.3	10	16	25	35	50	63	80	100	160	200	250
1.0						5 × 11 18	5 × 11 18	5 × 11 18	5 × 11 18			
1.5						5 × 11 21	5 × 11 21	5 × 11 21	5 × 11 21			
2.2						5 × 11 26	5 × 11 26	5 × 11 26	5 × 11 26			
3.3						5 × 11 32	5 × 11 32	5 × 11 32	5 × 11 32	10 × 16 49	10 × 16 42	10 × 20 46
4.7						5 × 11 38	5 × 11 38	5 × 11 38	6.3 × 11 44	10 × 16 59	10 × 20 55	12.5 × 20 63
6.8						5 × 11 46	5 × 11 46	6.3 × 11 52	8 × 11.5 62	10 × 20 77	12.5 × 20 78	12.5 × 20 78
10						5 × 11 55	6.3 × 11 64	6.3 × 11 64	8 × 11.5 75	12.5 × 20 109	12.5 × 20 95	12.5 × 25 103
15					5 × 11 61	6.3 × 11 78	6.3 × 11 78	8 × 11.5 92	10 × 12.5 107	12.5 × 20 134	12.5 × 25 127	16 × 25 140
22				5 × 11 73	6.3 × 11 84	6.3 × 11 94	8 × 11.5 111	10 × 12.5 129	10 × 16 142	12.5 × 25 177	16 × 25 170	16 × 31.5 186
33			5 × 11 78	6.3 × 11 103	6.3 × 11 103	8 × 11.5 136	10 × 12.5 158	10 × 16 173	10 × 20 189	16 × 25 240	16 × 35.5 239	18 × 35.5 256
47		5 × 11 87	6.3 × 11 107	6.3 × 11 123	8 × 11.5 145	10 × 12.5 189	10 × 16 207	10 × 20 226	12.5 × 20 265	16 × 35.5 329	18 × 40 321	
68	5 × 11 100	6.3 × 11 120	6.3 × 11 129	8 × 11.5 175	10 × 12.5 203	10 × 16 249	10 × 20 272	12.5 × 20 319	12.5 × 25 348	18 × 35.5 425		
100	6.3 × 11 139	6.3 × 11 145	8 × 11.5 184	10 × 12.5 247	10 × 16 270	10 × 20 329	10 × 20 329	12.5 × 20 387	16 × 25 468			
150	6.3 × 11 171	8 × 11.5 210	10 × 12.5 262	10 × 16 331	10 × 20 361	10 × 20 404	12.5 × 20 474	12.5 × 25 516	16 × 25 573			
220	8 × 11.5 244	10 × 12.5 295	10 × 16 347	10 × 20 437	10 × 20 437	12.5 × 20 574	12.5 × 25 625	16 × 25 694	16 × 35.5 797			
330	10 × 12.5 347	10 × 16 396	10 × 20 464	10 × 20 535	12.5 × 20 628	16 × 25 850	16 × 25 850	16 × 35.5 976	18 × 40 1098			
470	10 × 16 454	10 × 20 516	10 × 20 553	12.5 × 20 750	12.5 × 25 818	16 × 31.5 1110	16 × 35.5 1164	18 × 40 1311	22 × 41 1443			
680	10 × 20 595	12.5 × 20 729	12.5 × 20 781	12.5 × 25 984	16 × 25 1091	18 × 35.5 1503	18 × 40 1577	22 × 41 1736				
1000	12.5 × 20 847	12.5 × 20 883	12.5 × 25 1033	16 × 25 1323	16 × 35.5 1519	18 × 40 1912	22 × 41 2105					
1500	12.5 × 20 999	12.5 × 25 1132	16 × 25 1338	16 × 35.5 1748	18 × 40 1968	22 × 41 2386						
2200	12.5 × 25 1272	16 × 25 1463	16 × 35.5 1781	18 × 40 2254	22 × 41 2481							
3300	16 × 25 1672	16 × 35.5 1985	18 × 40 2360	22 × 41 2890								
4700	16 × 35.5 2221	18 × 40 2579	22 × 41 2987									
6800	18 × 41 2840	22 × 41 3214										
10000	22 × 41 3516	← Case size ØD × L (mm) ← Ripple current (mA rms) at 85°C, 120Hz										

# MINIATURE ALUMINUM ELECTROLYTIC CAPACITORS

**NS** Non-Polarized, Height 7mmL Series

- Non-polarized series with 7mmL height
- Load life of 2000 hours at 85°C
- Complied to the RoHS directive

**NP** Non-polarized  
**S** Solvent Proof

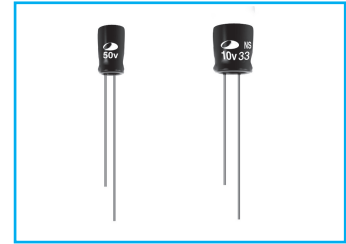

**SS** → **NS**  
Non-polar

Item	Characteristics								
Operating temperature range	-40 ~ +85°C								
Leakage current max.	$I = 0.05CV$ or $10\mu A$ whichever is greater (after 2 minutes)								
Capacitance tolerance	$\pm 20\%$ at 120Hz, 20°C								
Dissipation factor max. (at 120Hz, 20°C)	WV	6.3	10	16	25	35	40	50	63
	tan $\delta$	0.24	0.20	0.17	0.16	0.15	0.14	0.12	0.10
Low temperature characteristics (Impedance ratio at 120Hz)	WV	6.3	10	16~25	35~63				
	Z-25°C/Z+20°C	4	3	2	2				
	Z-40°C/Z+20°C	8	6	4	4				
Load life (after application of the rated voltage for 2000 hours at 85°C)	Leakage current	Less than specified value							
	Capacitance change	Within $\pm 20\%$ of initial value							
	tan $\delta$	Less than 200% of specified value							
	Test method	Polarity reverse each 250 hours							
Shelf life (at 85°C)	After 1000 hours no load test, leakage current, capacitance and tan $\delta$ are same as load life value. The measurement shall be performed at 20°C by the KS C IEC 60384 - 4								

## ● DRAWING

Unit : mm

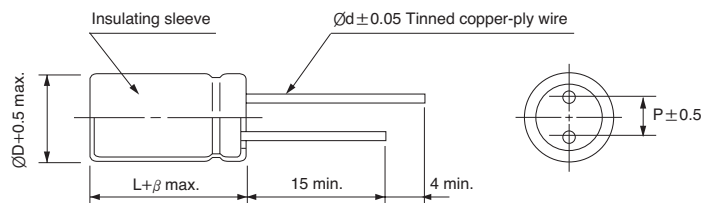

ØD	4	5	6.3
P	1.5	2.0	2.5
Ød	0.45	0.5	0.5
β	1.0	1.5	

## ● DIMENSIONS & MAXIMUM PERMISSIBLE RIPPLE CURRENT

µF \ WV	6.3	10	16	25	35	40	50	63						
1.0							4×7	13	4×7	14				
1.5							4×7	16	4×7	17				
2.2							4×7	19	5×7	24				
3.3				4×7	20	4×7	21	4×7	18	5×7	27	6.3×7	34	
4.7			4×7	23	4×7	24	5×7	29	5×7	25	6.3×7	37	6.3×7	40
6.8		4×7	26	5×7	32	5×7	33	6.3×7	39	5×7	29			
10		4×7	31	5×7	39	6.3×7	47	6.3×7	48	6.3×7	41			
15	4×7	35	5×7	44	6.3×7	55								
22	5×7	49	6.3×7	62	6.3×7	67								
33	6.3×7	69	6.3×7	76										
47	6.3×7	83												

↑ ↑  
 Ripple current (mA rms) at 85°C, 120Hz  
 Case size ØD×L (mm)

## ● FREQUENCY COEFFICIENT OF PERMISSIBLE RIPPLE CURRENT

Frequency	50Hz	120Hz	1kHz	10kHz $\leq$
Coefficient	0.75	1.00	1.55	2.00

# MINIATURE ALUMINUM ELECTROLYTIC CAPACITORS



## NE Non-Polarized, Height 5mmL Series

Miniaturized 
 Non-polarized 
 Solvent Proof

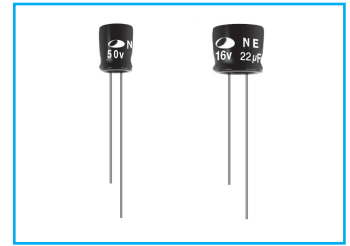

- Non-polarized and low profile series with 5mmL height
- Uniquely designed for use in lightweight and portable equipment
- Complied to the RoHS directive

SE → NE  
Non-polar

Item	Characteristics						
Operating temperature range	-40 ~ +85°C						
Leakage current max.	I = 0.05CV or 10µA whichever is greater (after 2 minutes)						
Capacitance tolerance	± 20% at 120Hz, 20°C						
Dissipation factor max. (at 120Hz, 20°C)	WV	6.3	10	16	25	35	50
	tanδ	0.24	0.20	0.17	0.17	0.15	0.15
Low temperature characteristics (Impedance ratio at 120Hz)	WV	6.3	10	16, 25	35, 50		
	Z-25°C/Z+20°C	4	3	2	2		
	Z-40°C/Z+20°C	8	6	4	3		
Load life (after application of the rated voltage for 1000 hours at 85°C)	Leakage current	Less than specified value					
	Capacitance change	Within ±20% of initial value					
	tanδ	Less than 200% of specified value					
	Test method	Polarity reverse each 250 hours					
Shelf life (at 85°C)	After 1000 hours no load test, leakage current, capacitance and tanδ are same as load life value. The measurement shall be performed at 20°C by the KS C IEC 60384 - 4						

### DRAWING

Unit : mm

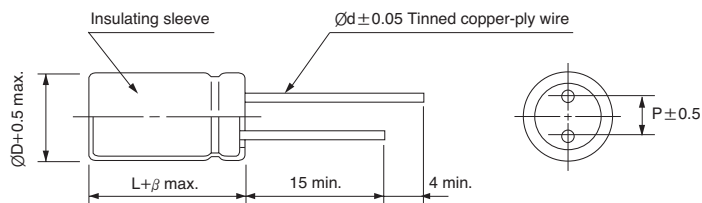

ØD	4	5	6.3
P	1.5	2.0	2.5
Ød	0.45	0.45	0.45
β	1.0	1.5	

### DIMENSIONS & MAXIMUM PERMISSIBLE RIPPLE CURRENT

µF \ WV	6.3		10		16		25		35		50	
1.0											4×5	10
1.5											4×5	12
2.2							4×5	14	4×5	15	5×5	17
3.3							5×5	20	5×5	21	5×5	21
4.7					4×5	21	5×5	24	5×5	25	6.3×5	30
6.8					5×5	29	6.3×5	33	6.3×5	36	6.3×5	36
10			4×5	28	5×5	35	6.3×5	41	6.3×5	43		
15	4×5	31	5×5	39	6.3×5	50						
22	5×5	43	6.3×5	55	6.3×5	60						
33	6.3×5	62	6.3×5	68								
47	6.3×5	74										

Ripple current (mA rms) at 85°C, 120Hz  
 Case size ØD×L (mm)

### FREQUENCY COEFFICIENT OF PERMISSIBLE RIPPLE CURRENT

Frequency	50Hz	120Hz	1kHz	10kHz ≤
Coefficient	0.75	1.00	1.55	2.00

MINIATURE TYPES

# MINIATURE ALUMINUM ELECTROLYTIC CAPACITORS

## RN Non-Polarized, Wide Temperature Range Series

- Wide operating temperature range of -40 ~ +105°C
- Designed for use in circuits with reversing polarity
- Complied to the RoHS directive

**NP** Non-polarized **S** Solvent Proof

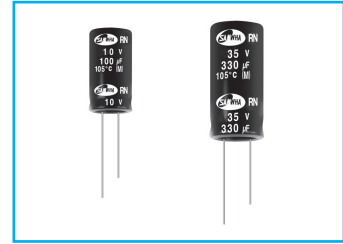

**RD** ⇒ **RN**  
Non-polar

Item	Characteristics																			
Operating temperature range	-40 ~ +105°C																			
Leakage current max.	$I = 0.03CV$ or $3\mu A$ whichever is greater (after 5 minutes)																			
Capacitance tolerance	$\pm 20\%$ at 120Hz, 20°C																			
Dissipation factor max. (at 120Hz, 20°C)	Capacitance > 1000 $\mu F$ : $\tan\delta$ increases by 0.02 for each 1000 $\mu F$ from below value.																			
	<table border="1"> <thead> <tr> <th>WV</th> <th>6.3</th> <th>10</th> <th>16</th> <th>25</th> <th>35</th> <th>50</th> <th>63</th> <th>80</th> <th>100</th> </tr> </thead> <tbody> <tr> <td><math>\tan\delta</math></td> <td>0.24</td> <td>0.20</td> <td>0.16</td> <td>0.16</td> <td>0.14</td> <td>0.12</td> <td>0.12</td> <td>0.12</td> <td>0.12</td> </tr> </tbody> </table>	WV	6.3	10	16	25	35	50	63	80	100	$\tan\delta$	0.24	0.20	0.16	0.16	0.14	0.12	0.12	0.12
WV	6.3	10	16	25	35	50	63	80	100											
$\tan\delta$	0.24	0.20	0.16	0.16	0.14	0.12	0.12	0.12	0.12											
Low temperature characteristics (Impedance ratio at 120Hz)	<table border="1"> <thead> <tr> <th>WV</th> <th>6.3</th> <th>10</th> <th>16</th> <th>25 ~ 100</th> </tr> </thead> <tbody> <tr> <td>Z-25°C/Z+20°C</td> <td>4</td> <td>3</td> <td>2</td> <td>2</td> </tr> <tr> <td>Z-40°C/Z+20°C</td> <td>8</td> <td>6</td> <td>4</td> <td>3</td> </tr> </tbody> </table>	WV	6.3	10	16	25 ~ 100	Z-25°C/Z+20°C	4	3	2	2	Z-40°C/Z+20°C	8	6	4	3				
	WV	6.3	10	16	25 ~ 100															
	Z-25°C/Z+20°C	4	3	2	2															
Z-40°C/Z+20°C	8	6	4	3																
Load life (after application of the rated voltage for 1000 hours at 105°C)	Leakage current	Less than specified value																		
	Capacitance change	Within $\pm 20\%$ of initial value																		
	$\tan\delta$	Less than 200% of specified value																		
	Test method	Polarity reverse each 250 hours																		
Shelf life (at 105°C)	After 1000 hours no load test, leakage current, capacitance and $\tan\delta$ are same as load life value. The measurement shall be performed at 20°C by the KS C IEC 60384 - 4																			

### DRAWING

Unit : mm

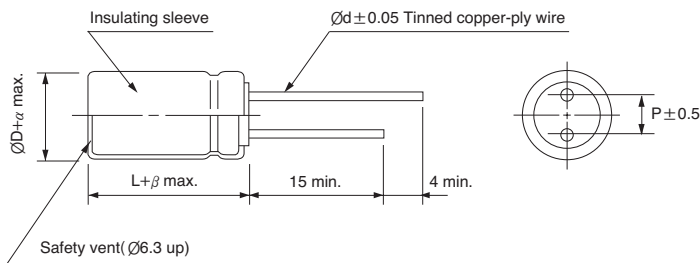

ØD	5	6.3	8	10	12.5	16	18	22
P	2.0	2.5	3.5	5.0	5.0	7.5	7.5	10.0
Ød	0.5	0.5	0.6	0.6	0.6	0.8	0.8	1.0
α	0.5							1.0
β	1.5		2.0				3.0	

### FREQUENCY COEFFICIENT OF PERMISSIBLE RIPPLE CURRENT

µF	Frequency	50Hz	120Hz	1kHz	10kHz ≤
~ 47		0.75	1.00	1.55	2.00
68 ~ 680		0.80	1.00	1.34	1.50
1000 ~		0.85	1.00	1.13	1.15

## RN series

### ● DIMENSIONS & MAXIMUM PERMISSIBLE RIPPLE CURRENT

$\mu\text{F}$ \diagdown WV	6.3	10	16	25	35	50	63	80	100
1.0						5 × 11 11	5 × 11 12	5 × 11 12	
1.5						5 × 11 14	5 × 11 15	5 × 11 15	5 × 11 16
2.2						5 × 11 17	5 × 11 18	5 × 11 18	5 × 11 19
3.3						5 × 11 21	5 × 11 23	6.3 × 11 26	6.3 × 11 27
4.7					5 × 11 23	5 × 11 25	6.3 × 11 31	6.3 × 11 31	8 × 11.5 39
6.8				5 × 11 26	5 × 11 27	6.3 × 11 34	6.3 × 11 37	8 × 11.5 44	10 × 12.5 54
10			5 × 11 31	5 × 11 31	6.3 × 11 38	6.3 × 11 41	8 × 11.5 53	10 × 12.5 62	10 × 12.5 65
15		5 × 11 34	5 × 11 38	6.3 × 11 44	8 × 11.5 55	8 × 11.5 60	10 × 12.5 76	10 × 12.5 76	10 × 16 88
22	5 × 11 38	5 × 11 41	6.3 × 11 53	8 × 11.5 63	8 × 11.5 67	10 × 12.5 84	10 × 16 101	10 × 16 101	
33	5 × 11 46	6.3 × 11 58	8 × 11.5 77	8 × 11.5 77	10 × 12.5 95	10 × 16 113	10 × 16 124	10 × 20 135	
47	6.3 × 11 63	6.3 × 11 69	8 × 11.5 92	10 × 12.5 106	10 × 16 125	10 × 20 147	10 × 20 161	12.5 × 20 189	
68	6.3 × 11 76	8 × 11.5 98	10 × 12.5 128	10 × 16 140	10 × 20 164	10 × 20 177	12.5 × 20 227	12.5 × 25 248	
100	8 × 11.5 109	10 × 12.5 139	10 × 16 170	10 × 20 185	10 × 20 198	12.5 × 20 251	12.5 × 25 300	16 × 25 333	
150	10 × 12.5 155	10 × 16 186	10 × 20 227	12.5 × 20 267	12.5 × 20 285	12.5 × 25 336	16 × 25 408	16 × 35.5 468	
220	10 × 12.5 188	10 × 20 246	12.5 × 20 323	12.5 × 20 323	12.5 × 25 376	16 × 25 451	16 × 35.5 567	18 × 35.5 609	
330	10 × 16 252	12.5 × 20 354	12.5 × 20 396	12.5 × 25 431	16 × 25 511	16 × 35.5 634	18 × 35.5 745	18 × 40 782	
470	10 × 20 328	12.5 × 20 422	12.5 × 25 515	16 × 25 571	16 × 35.5 701	18 × 35.5 812	18 × 40 933	22 × 41 1027	
680	12.5 × 20 464	12.5 × 25 554	16 × 25 687	16 × 35.5 788	18 × 35.5 904	18 × 40 1025	22 × 41 1236		
1000	12.5 × 25 613	16 × 25 745	16 × 35.5 956	18 × 35.5 1026	18 × 40 1151	22 × 41 1368			
1500	16 × 25 800	16 × 35.5 999	18 × 35.5 1184	18 × 40 1243	22 × 41 1451				
2200	16 × 35.5 1072	18 × 35.5 1242	18 × 40 1428	22 × 41 1572					
3300	18 × 35.5 1361	18 × 40 1534	22 × 41 1835	← Case size $\varnothing D \times L$ (mm) ← Ripple current (mA rms) at 105°C, 120Hz					
4700	18 × 40 1650	22 × 41 1942							
6800	22 × 41 2060								



## MINIATURE ALUMINUM ELECTROLYTIC CAPACITORS

---

# 5 LARGE ALUMINUM ELECTROLYTIC CAPACITORS

---



# LARGE ALUMINUM ELECTROLYTIC CAPACITORS

## PART NUMBER SYSTEM

### ● Part Number System

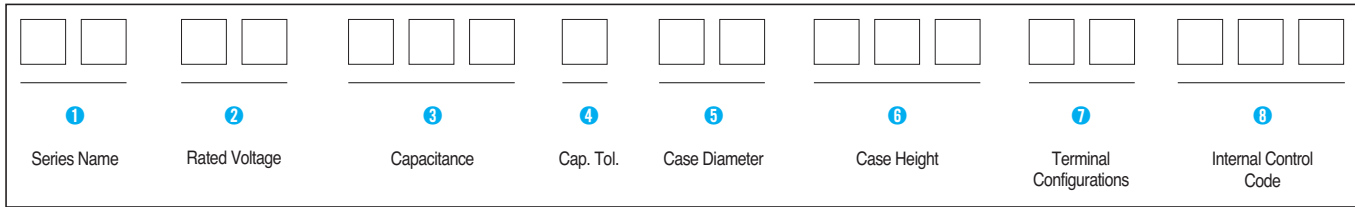

#### 1 Series Name See page 8

#### 2 Rated Working Voltage

<b>WV</b>	<b>6.3</b>	<b>10</b>	<b>16</b>	<b>25</b>	<b>35</b>
<b>Code</b>	0J	1A	1C	1E	1V
<b>WV</b>	<b>40</b>	<b>50</b>	<b>63</b>	<b>80</b>	<b>100</b>
<b>Code</b>	1G	1H	1J	1K	2A
<b>WV</b>	<b>160</b>	<b>200</b>	<b>220</b>	<b>250</b>	<b>315</b>
<b>Code</b>	2C	2D	7D	2E	2F
<b>WV</b>	<b>330</b>	<b>350</b>	<b>360</b>	<b>375</b>	<b>400</b>
<b>Code</b>	2L	2V	2Z	7S	2G
<b>WV</b>	<b>450</b>	<b>475</b>	<b>500</b>	<b>550</b>	<b>600</b>
<b>Code</b>	2W	7W	2H	7H	2X

#### 3 Capacitance

ex) 47 $\mu$ F    476  
 470 $\mu$ F    477  
 4700 $\mu$ F    478  
 47000 $\mu$ F    479

#### 4 Capacitance Tolerance

<b>Tolerance (%)</b>	$\pm 10$	$\pm 15$	$\pm 20$	0 +20	-10 +20	-10 +30	-10 +50	-10 +75
<b>Code</b>	K	L	M	W	V	Q	T	U

#### 5 Case Diameter

ex)  $\varnothing 22$     22  
 $\varnothing 25.4$     25  
 $\varnothing 30$     30  
 $\varnothing 35$     35  
 $\varnothing 40$     40  
 $\varnothing 51$     51  
 $\varnothing 63.5$     64  
 $\varnothing 76.2$     76  
 $\varnothing 89$     89

#### 6 Case Height

ex) 30mm    030  
 105mm    105

#### 7 Terminal Configurations

Terminal Configurations		Code
Snap-in Terminal for PC board mounting	Terminal Length 6mm	HA
	Terminal Length 4mm	HC
Lug Terminal for Soldering	$\varnothing D \leq 35$	LC
	$\varnothing D = 40$	LA
	$\varnothing D = 51$	LD
	$\varnothing D \geq 63.5$	LE
Photo Flash	$\varnothing D = 22$	PK
	$\varnothing D = 25.4, 30$	LC
	$\varnothing D = 35$	LF
Screw Terminal Type		SB
Screw Terminal Type (Stud Type)		TB
Screw Terminal Type (M6)		S6
Screw Terminal Type (Stud Type, M6)		T6

# PACKING

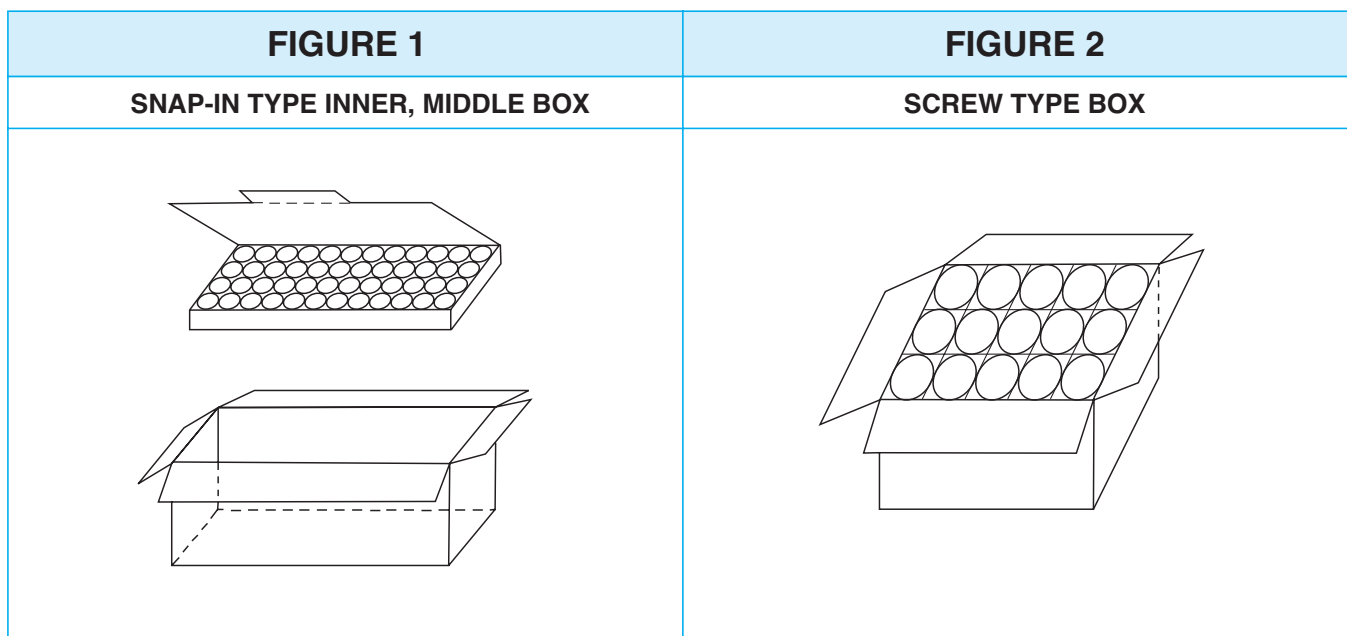

● SNAP-IN TYPE PACKAGING Quantity (pcs) / BOX (FIGURE 1)

ØD	SIZE	SNAP-IN(QUANTITY)	
	L	INNER BOX	MIDDLE BOX
22	20 ~ 40	200	600
	45 ~ 50		
25	20 ~ 45	150	450
	50 ~ 60	150	300
30	20 ~ 40	100	300
	45 ~ 55	100	200
	60 ~ 80		
35	20 ~ 40	50	200
	45 ~ 55		150
	60 ~ 80		
	100 ~ 120		
40	30 ~ 40	50	150
	50		
	60 ~ 80		100
	90 ~ 110		

● SCREW TYPE PACKAGING Quantity (pcs) / BOX & BOX SIZE (FIGURE 2)

SIZE	SCREW
ØD	QUANTITY
35	45
51	23
64	16
76	12
89	9

# LARGE ALUMINUM ELECTROLYTIC CAPACITORS

## ● SNAP-IN DRAWING

STANDARD 2 PIN (Ø22~Ø40)	2 PIN - 1 (Ø25, Ø30, Ø35)	4 PIN (Ø35, Ø40)
<p>Type : HA, HC</p>	<p>Type : HR</p>	<p>Type : HA, HC (4pin)</p>

## ● SCREW CASE DRAWING

STANDARD	STUD TYPE
<p>Type : SB</p>	<p>Type : TB</p>

## ● STUD TYPE DRAWING

NON-INSULATED VERSION	INSULATED VERSION	Stud Type Washer	
		<p>Stud Type Nut</p>	
<p>Stud Type Washer</p> <p>Stud Type Nut</p>	<p>Insulation Cap</p>	<p>Insulation Cap (A Type)</p>	

## HC Snap-in Terminal Type, Standard Series

- Standard snap-in terminal type
- Including 550WV products
- Complied to the RoHS directive



Item	Characteristics																	
Operating temperature range	WV < 350 : -40 ~ +85°C, WV ≥ 350 : -25 ~ +85°C																	
Capacitance tolerance	±20% at 120Hz, 20°C																	
Leakage current max.	$I = 3 \sqrt{CV}$ (µA) (after 5 minutes)																	
Dissipation factor max. (at 120Hz, 20°C)	Capacitance > 1000µF : tanδ increases by 0.01 for each 1000µF from below value.																	
	<table border="1"> <thead> <tr> <th>WV</th> <th>6.3</th> <th>10</th> <th>16, 25</th> <th>35</th> <th>50, 63</th> <th>80, 100</th> <th>160 ~ 400</th> <th>450~550</th> </tr> </thead> <tbody> <tr> <td>tanδ</td> <td>0.45</td> <td>0.40</td> <td>0.35</td> <td>0.30</td> <td>0.25</td> <td>0.20</td> <td>0.15</td> <td>0.20</td> </tr> </tbody> </table>	WV	6.3	10	16, 25	35	50, 63	80, 100	160 ~ 400	450~550	tanδ	0.45	0.40	0.35	0.30	0.25	0.20	0.15
WV	6.3	10	16, 25	35	50, 63	80, 100	160 ~ 400	450~550										
tanδ	0.45	0.40	0.35	0.30	0.25	0.20	0.15	0.20										
Load life (after application of the rated voltage for 2000 hours at 85°C)	Leakage current	Less than specified value																
	Capacitance change	Within ±20% of initial value																
	tanδ	Less than 200% of specified value																
Shelf life (at 85°C)	After 1000 hours no load test, leakage current, capacitance and tanδ are same as load life value. The measurement shall be performed at 20°C by the KS C IEC 60384 - 4																	

### DRAWING

Unit : mm

#### • ∅D ≤ 40

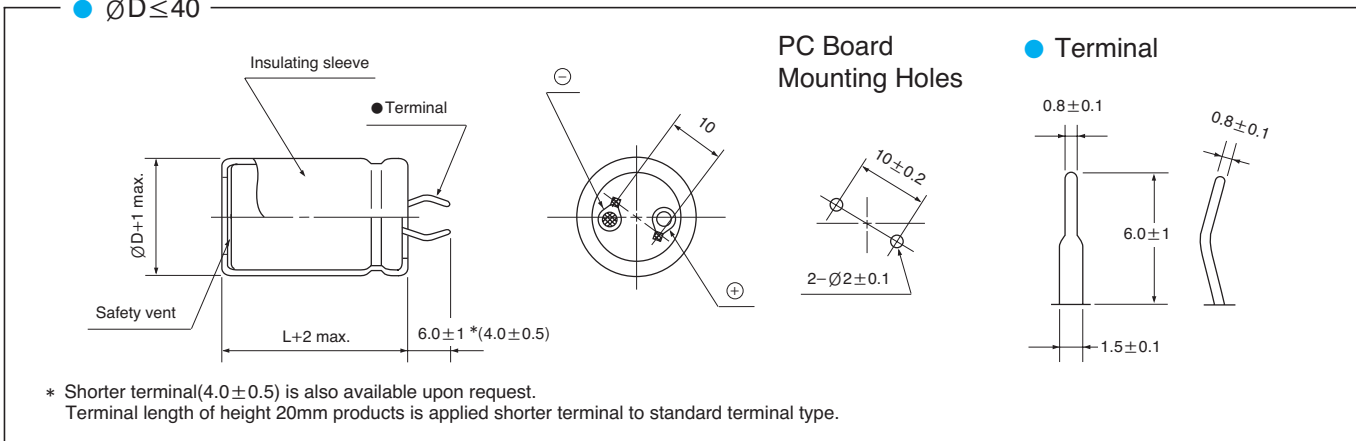

#### • ∅D = 35, 40

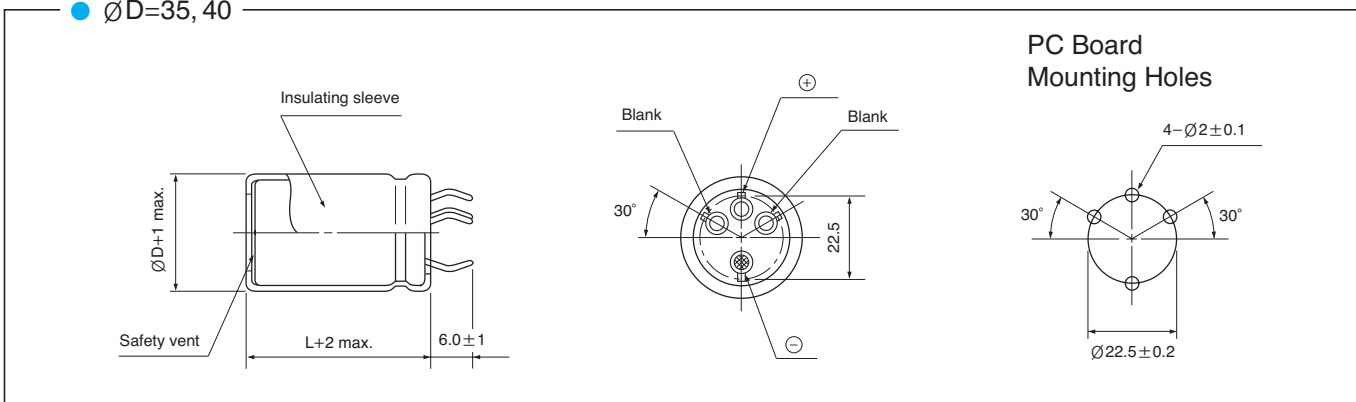

### FREQUENCY COEFFICIENT OF PERMISSIBLE RIPPLE CURRENT

WV	Frequency	50Hz	120Hz	300Hz	1kHz	10kHz ≤
~ 100		0.85	1.00	1.06	1.15	1.20
160 ~ 250		0.85	1.00	1.20	1.25	1.45
315 ~		0.85	1.00	1.15	1.20	1.40

# LARGE ALUMINUM ELECTROLYTIC CAPACITORS

**HC** series

● DIMENSIONS & MAXIMUM PERMISSIBLE RIPPLE CURRENT

WV μF ∅D	6.3					10					16				
	22	25.4	30	35	40	22	25.4	30	35	40	22	25.4	30	35	40
10000											22×25 3.32				
12000						22×25 3.31					22×30 3.55	25.4×25 3.89			
15000	22×25 3.39					22×30 3.42	25.4×25 3.39				22×35 4.29	25.4×30 4.45	30×25 4.56		
18000	22×30 3.85	25.4×25 3.96				22×35 4.28	25.4×25 4.17				22×40 4.77	25.4×35 4.96	30×30 5.10		
22000	22×35 4.34	25.4×25 4.22				22×40 4.79	25.4×30 4.71	30×25 4.83			22×50 5.51	25.4×40 5.51	30×30 5.39		
27000	22×40 4.85	25.4×30 4.77	30×25 4.89			22×45 5.30	25.4×30 5.26	30×30 5.41				25.4×45 6.06	30×35 5.98	35×25 5.80	
33000	22×45 5.36	25.4×35 5.32	30×30 5.47			22×50 5.82	25.4×40 5.81	30×30 5.69	35×25 5.81				30×40 6.56	35×30 6.41	
39000	22×50 5.83	25.4×40 5.82	30×30 5.70	35×25 5.82			25.4×45 6.31	30×35 6.22	35×30 6.38				30×45 7.08	35×35 6.96	
47000		25.4×45 6.35	30×35 6.26	35×30 6.41			25.4×50 6.83	30×40 6.78	35×30 6.62				30×50 7.62	35×40 7.54	
56000		25.4×50 6.85	30×40 6.80	35×30 6.64				30×45 7.31	35×35 7.18					35×45 8.08	40×40 8.23
68000			30×45 7.35	35×35 7.23					35×40 7.76					35×50 8.63	40×50 9.13
100000				35×45 8.34	40×40 8.49										40×60 10.2

WV μF ∅D	25					35					50				
	22	25.4	30	35	40	22	25.4	30	35	40	22	25.4	30	35	40
3300											22×30 2.97	25.4×25 3.06			
4700						22×30 3.06	25.4×25 2.98				22×40 3.83	25.4×35 3.98	30×25 3.86	35×25 4.19	
5600	22×25 2.65					22×35 3.28	25.4×30 3.39				22×45 4.26	25.4×40 4.44	30×30 4.35	35×25 4.44	
6800	22×30 3.06	25.4×25 3.15				22×40 3.73	25.4×30 3.67	30×25 3.76			22×50 4.77	25.4×40 4.76	30×35 4.92	35×30 5.04	
8200	22×35 3.45	25.4×30 3.57				22×45 4.13	25.4×35 4.10	30×30 4.22				25.4×50 5.43	30×40 5.38	35×30 5.26	
10000	22×40 3.95	25.4×30 3.89	30×25 3.99			22×50 4.68	25.4×40 4.68	30×30 4.58					30×45 6.07	35×35 5.97	
12000	22×45 4.41	25.4×35 4.37	30×30 4.50				25.4×45 5.18	30×35 5.11	35×30 5.24				30×50 6.62	35×40 6.55	
15000	22×50 4.94	25.4×40 4.94	30×35 5.10					30×40 5.72	35×35 5.88					35×45 7.20	
18000		25.4×45 5.45	30×35 5.38	35×30 5.51				30×45 6.28	35×40 6.46					35×50 7.74	40×40 7.62
22000			30×45 6.22	35×35 6.12					35×45 7.07	40×40 7.20					40×50 8.54
27000			30×50 6.82	35×40 6.74						40×50 8.14					40×60 9.45
33000				35×45 7.35	40×40 7.48					40×50 8.46					

WV μF ∅D	63					80					100				
	22	25.4	30	35	40	22	25.4	30	35	40	22	25.4	30	35	40
1200						22×25 2.24					22×30 2.39	25.4×25 2.46			
1500						22×30 2.67					22×35 2.83	25.4×30 2.93	30×25 3.00		
1800	22×25 2.20					22×30 2.92	25.4×25 3.01				22×40 3.26	25.4×35 3.39	30×30 3.49		
2200	22×30 2.50	25.4×25 2.58				22×35 3.25	25.4×30 3.36	30×25 3.45			22×45 3.58	25.4×40 3.74	30×30 3.66		
2700	22×35 2.94	25.4×30 3.04				22×40 3.79	25.4×35 3.94	30×30 4.05				25.4×45 4.33	30×35 4.27	35×30 4.37	
3300	22×35 3.14	25.4×30 3.26	30×25 3.34			22×45 4.18	25.4×40 4.36	30×30 4.27				25.4×50 4.76	30×40 4.72	35×35 4.85	
3900	22×40 3.60	25.4×35 3.74	30×30 3.85			22×50 4.75	25.4×45 4.96	30×35 4.89					30×45 5.36	35×35 5.27	
4700	22×50 4.19	25.4×40 4.19	30×35 4.10	35×30 4.19			25.4×50 5.44	30×40 5.39	35×30 5.27				30×50 5.86	35×40 5.80	
5600		25.4×45 4.65	30×35 4.58	35×30 4.70				30×45 5.91	35×35 5.81					35×45 6.34	40×40 6.45
6800		25.4×50 5.20	30×40 5.16	35×30 5.04					35×40 6.45						40×50 7.40
8200			30×45 5.62	35×35 5.53					35×45 6.91	40×40 7.04					40×50 7.60
10000			30×50 6.32	35×40 6.25						40×50 8.14	← Case size ∅D×L (mm) ← Ripple current (Arms) at 85°C, 120Hz				
12000				35×45 6.83	40×40 6.95										

## HC series

### ● DIMENSIONS & MAXIMUM PERMISSIBLE RIPPLE CURRENT

WV μF / ØD	160					200					250				
	22	25.4	30	35	40	22	25.4	30	35	40	22	25.4	30	35	40
150											22×25 0.90	25.4×20 0.92			
180						22×20 0.91					22×25 0.90	25.4×20 1.01			
220	22×20 1.01					22×25 1.09	25.4×20 1.11				22×25 1.09	25.4×25 1.19	30×20 1.22		
270	22×25 1.20	25.4×20 1.32				22×25 1.20	25.4×25 1.32	30×20 1.35			22×30 1.28	25.4×25 1.32	30×20 1.35		
330	22×25 1.33	25.4×20 1.36				22×30 1.42	25.4×25 1.46	30×20 1.49			22×30 1.42	25.4×30 1.56	30×20 1.49		
390	22×25 1.45	25.4×25 1.59	30×20 1.62			22×30 1.54	25.4×25 1.59	30×25 1.74			22×35 1.63	25.4×30 1.69	30×25 1.73		
470	22×30 1.69	25.4×25 1.75	30×20 1.78			22×35 1.79	25.4×30 1.86	30×25 1.90			22×40 1.89	25.4×30 1.84	30×25 1.90	35×25 2.06	
560	22×35 1.96	25.4×30 2.03	30×25 2.08			22×40 2.06	25.4×35 2.14	30×25 2.08	35×25 2.25		22×50 2.26	25.4×40 2.25	30×30 2.20	35×25 2.25	
680	22×40 2.27	25.4×30 2.23	30×25 2.29			22×45 2.38	25.4×40 2.48	30×30 2.43	35×25 2.48			25.4×45 2.60	30×35 2.56	35×30 2.62	
820	22×45 2.61	25.4×35 2.59	30×30 2.67	35×25 2.73		22×50 2.73	25.4×45 2.85	30×35 2.81	35×30 2.88			25.4×45 2.82	30×40 2.95	35×30 2.88	
1000	22×50 3.01	25.4×40 3.01	30×30 2.95	35×25 3.01				30×40 3.26	35×30 3.18				30×45 3.40	35×35 3.35	
1200		25.4×45 3.23	30×35 3.18	35×30 3.26				30×45 3.49	35×35 3.43					35×40 3.59	40×40 3.81
1500			30×40 3.73	35×35 3.83				30×50 4.06	35×40 4.01					35×50 4.35	40×50 4.60
1800				35×40 4.39	40×40 4.66				35×45 4.58	40×40 4.66					40×60 5.39

WV μF / ØD	315					350					400				
	22	25.4	30	35	40	22	25.4	30	35	40	22	25.4	30	35	40
68											22×20 0.56	25.4×20 0.61			
82						22×20 0.62					22×25 0.66	25.4×20 0.68			
100	22×20 0.68					22×25 0.73	25.4×20 0.75				22×25 0.74	25.4×25 0.81	30×20 0.82		
120	22×25 0.80	25.4×20 0.82				22×25 0.81	25.4×25 0.88	30×20 0.90			22×30 0.86	25.4×25 0.88	30×20 0.90		
150	22×25 0.89	25.4×25 0.99	30×20 1.01			22×30 0.96	25.4×25 0.97	30×20 1.01			22×30 0.96	25.4×30 1.05	30×25 1.08		
180	22×30 1.05	25.4×25 1.07	30×20 1.10			22×35 1.12	25.4×30 1.14	30×25 1.18			22×40 1.17	25.4×35 1.21	30×25 1.18	35×25 1.28	
220	22×35 1.23	25.4×30 1.27	30×25 1.30			22×40 1.29	25.4×30 1.26	30×25 1.30	35×25 1.41		22×45 1.35	25.4×40 1.41	30×30 1.38	35×25 1.41	
270	22×40 1.43	25.4×30 1.40	30×25 1.44	35×25 1.56			25.4×35 1.47	30×30 1.53	35×25 1.65			25.4×40 1.55	30×30 1.55	35×25 1.56	
330	22×50 1.73	25.4×35 1.63	30×30 1.69	35×25 1.73			25.4×40 1.71	30×35 1.78	35×30 1.83			25.4×45 1.80	30×35 1.78	35×30 1.83	
390		25.4×40 1.86	30×35 1.94	35×30 1.99				30×40 2.03	35×30 1.98				30×40 2.03	35×30 1.98	
470			30×35 2.13	35×30 2.18				30×40 2.23	35×35 2.30				30×45 2.30	35×35 2.30	
560			30×40 2.44	35×35 2.50				30×45 2.55	35×40 2.62					35×40 2.62	40×40 2.78
680			30×45 2.80	35×40 2.88				30×50 2.92	35×45 3.01	40×40 3.06				35×50 3.13	40×50 3.31
820			30×50 3.21	35×50 3.44	40×40 3.37				35×50 3.44	40×50 3.63					40×60 3.89

WV μF / ØD	450					500					550				
	22	25.4	30	35	40	22	25.4	30	35	40	22	25.4	30	35	40
47											22×30 0.41	25.4×25 0.42	30×20 0.43		
56	22×20 0.51										22×30 0.45	25.4×30 0.49	30×25 0.50		
68	22×25 0.60	25.4×20 0.61				22×25 0.64					22×35 0.52	25.4×30 0.53	30×25 0.55		
82	22×30 0.71	25.4×25 0.72	30×20 0.74			22×30 0.76	25.4×25 0.77				22×40 0.60	25.4×35 0.62	30×30 0.64	35×25 0.66	
100	22×30 0.78	25.4×30 0.85	30×25 0.88			22×40 0.92	25.4×30 0.92	30×25 0.94			22×45 0.70	25.4×40 0.72	30×30 0.71	35×25 0.73	
120	22×35 0.91	25.4×30 0.93	30×25 0.96				25.4×40 1.09	30×30 1.09				25.4×45 0.83	30×35 0.82	35×30 0.84	
150	22×40 1.07	25.4×35 1.10	30×30 1.14	35×25 1.16				30×30 1.10				25.4×50 0.96	30×40 0.96	35×35 0.99	
180		25.4×35 1.20	30×30 1.25	35×25 1.28				30×35 1.26					30×45 1.10	35×35 1.08	
220		25.4×40 1.40	30×35 1.45	35×30 1.49				30×40 1.46	35×30 1.75					35×45 1.33	40×40 1.33
270			30×40 1.62	35×30 1.65					35×35 1.83					35×50 1.51	40×50 1.59
330			30×45 1.94	35×35 1.94					35×40 1.94						40×50 1.76
390			30×50 2.21	35×35 2.09					35×45 2.16						40×60 2.05
470			30×50 2.42	35×40 2.42	40×40 2.55				35×50 2.23	40×50 2.94					40×60 2.25
560				35×50 2.84	40×50 3.00					40×60 3.43					
680					40×60 3.54					40×60 3.78					

← Case size ØD×L (mm)  
← Ripple current (Arms) at 85°C, 120Hz



# LARGE ALUMINUM ELECTROLYTIC CAPACITORS

## HJ Snap-in Terminal Type, Series

- High voltage, high capacitance series
- Load life of 3000 hours at 85°C
- Complied to the RoHS directive



Item	Characteristics															
Operating temperature range	WV<350 : -40 ~ +85°C, WV ≥ 350 : -25 ~ +85°C															
Capacitance tolerance	± 20% at 120Hz, 20°C															
Leakage current max.	$I=3\sqrt{CV}$ (μA) (after 5 minutes)															
Dissipation factor max. (at 120Hz, 20°C)	Capacitance > 1000μF : tanδ increases by 0.01 for each 1000μF from below value.															
	<table border="1"> <thead> <tr> <th>WV</th> <th>10</th> <th>16, 25</th> <th>35</th> <th>50, 63</th> <th>80, 100</th> <th>160 ~ 400</th> <th>450, 500</th> </tr> </thead> <tbody> <tr> <td>tanδ</td> <td>0.40</td> <td>0.35</td> <td>0.30</td> <td>0.25</td> <td>0.20</td> <td>0.15</td> <td>0.20</td> </tr> </tbody> </table>	WV	10	16, 25	35	50, 63	80, 100	160 ~ 400	450, 500	tanδ	0.40	0.35	0.30	0.25	0.20	0.15
WV	10	16, 25	35	50, 63	80, 100	160 ~ 400	450, 500									
tanδ	0.40	0.35	0.30	0.25	0.20	0.15	0.20									
Load life (after application of the rated voltage for 3000 hours at 85°C)	Leakage current	Less than specified value														
	Capacitance change	Within ± 20% of initial value														
	tanδ	Less than 200% of specified value														
Shelf life (at 85°C)	After 1000 hours no load test, leakage current, capacitance and tanδ are same as load life value. The measurement shall be performed at 20°C by the KS C IEC 60384 - 4															

### ● DRAWING

Unit : mm

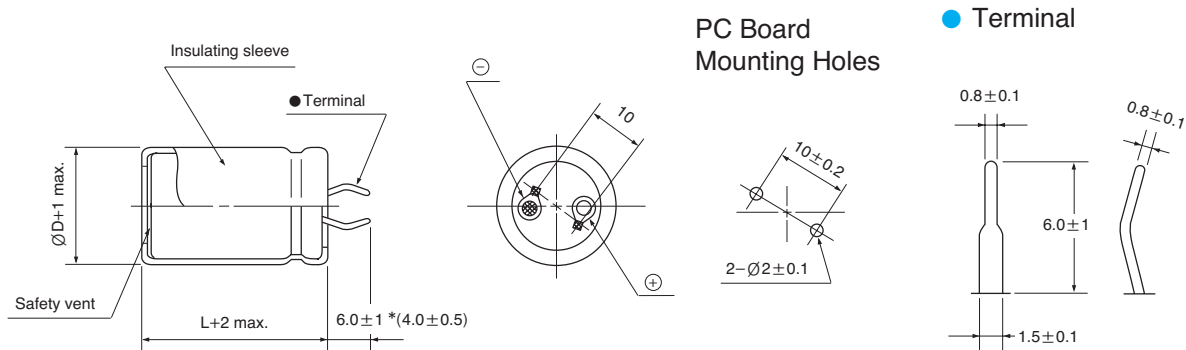

\* Shorter terminal(4.0±0.5) is also available upon request.  
Terminal length of height 20mm products is applied shorter terminal to standard terminal type.

### ● FREQUENCY COEFFICIENT OF PERMISSIBLE RIPPLE CURRENT

WV	Frequency	50Hz	120Hz	300Hz	1kHz	10kHz ≤
~ 100	~ 100	0.85	1.00	1.06	1.15	1.20
	160 ~ 250	0.85	1.00	1.20	1.25	1.45
350 ~		0.85	1.00	1.15	1.20	1.40

# LARGE ALUMINUM ELECTROLYTIC CAPACITORS



**HJ** series

● DIMENSIONS & MAXIMUM PERMISSIBLE RIPPLE CURRENT

WV μF / ØD	10				16				25			
	22	25.4	30	35	22	25.4	30	35	22	25.4	30	35
6800									22×25 2.24			
8200									22×30 2.61			
10000					22×30 2.68				22×35 3.24	25.4×30 3.14	30×25 3.25	
12000	22×25 2.39				22×35 3.12	25.4×25 3.00			22×40 3.70	25.4×35 3.63	30×25 3.56	
15000	22×30 2.86				22×40 3.67	25.4×30 3.58	30×25 3.70			25.4×40 4.09	30×30 4.00	35×25 4.07
18000	22×35 3.21	25.4×25 3.05			22×45 4.15	25.4×35 4.13	30×25 3.93			25.4×45 4.62	30×35 4.60	35×30 4.64
22000	22×40 3.74	25.4×30 3.64				25.4×40 4.44	30×30 4.38			25.4×50 5.14	30×40 5.17	35×30 5.05
27000	22×45 4.06	25.4×35 3.98	30×25 3.57			25.4×45 4.89	30×35 4.84	35×25 4.71			30×45 5.98	35×35 5.88
33000		25.4×40 4.50	30×30 3.99	35×25 4.57			30×40 5.50	35×30 5.41				35×40 6.59
39000		25.4×45 5.17	30×30 4.55	35×30 5.18			30×45 6.19	35×35 6.09				
47000			30×35 5.15	35×35 5.76			30×50 6.80	35×40 6.75				
56000			30×40 5.61	35×40 6.45								

WV μF / ØD	35				50				63			
	22	25.4	30	35	22	25.4	30	35	22	25.4	30	35
2200									22×30 2.15			
2700					22×25 1.95				22×30 2.38	25.4×25 2.42		
3300					22×30 2.40	25.4×25 2.35			22×35 2.72	25.4×30 2.74		
3900	22×25 1.89				22×30 2.50	25.4×25 2.50			22×40 3.07	25.4×35 3.16	30×25 3.00	
4700	22×30 2.29	25.4×25 2.26			22×35 2.91	25.4×30 2.98	30×25 3.01		22×45 3.44	25.4×40 3.55	30×30 3.51	
5600	22×30 2.42	25.4×25 2.42			22×40 3.31	25.4×35 3.44	30×30 3.42		22×50 3.92	25.4×45 4.01	30×35 3.98	35×30 3.93
6800	22×35 2.82	25.4×30 2.89	30×25 2.89		22×45 3.70	25.4×40 3.81	30×35 3.93	35×25 3.80		25.4×50 4.47	30×40 4.48	35×30 4.38
8200	22×40 3.26	25.4×35 3.30	30×25 3.19			25.4×45 4.32	30×40 4.51	35×30 4.41			30×45 5.07	35×35 4.99
10000	22×45 3.57	25.4×40 3.65	30×30 3.60	35×25 3.60		25.4×50 4.83	30×45 5.04	35×35 4.88			30×50 5.75	35×40 5.68
12000		25.4×45 4.15	30×35 4.13	35×30 4.23			30×45 5.44	35×40 5.60				35×45 6.47
15000		25.4×50 4.76	30×40 4.76	35×35 4.90				35×45 6.53				
18000			30×45 5.22	35×40 5.44				35×45 7.04				
22000				35×45 6.28								
27000				35×50 6.90								

WV μF / ØD	80				100			
	22	25.4	30	35	22	25.4	30	35
1200	22×25 1.77				22×30 2.02	25.4×25 2.06		
1500	22×30 2.00	25.4×25 2.02			22×35 2.40	25.4×30 2.45		
1800	22×35 2.35	25.4×30 2.35			22×40 2.76	25.4×35 2.81	30×30 2.84	
2200	22×40 2.86	25.4×30 2.79	30×25 2.85		22×45 3.00	25.4×40 3.10	30×30 3.06	35×25 3.13
2700	22×45 3.23	25.4×35 3.05	30×30 3.17			25.4×45 3.59	30×35 3.57	35×30 3.66
3300	22×50 3.18	25.4×40 3.28	30×30 3.24				30×40 4.15	35×35 4.18
3900		25.4×45 3.62	30×35 3.60				30×45 4.58	35×35 4.51
4700		25.4×50 4.22	30×40 4.23	35×30 4.12				35×40 5.18
5600			30×45 4.66	35×35 4.59				35×50 5.91
6800				35×40 5.20				
8200				35×45 5.86				
10000				35×50 6.61				

Case size ØD×L (mm)  
Ripple current (A rms) at 85°C, 120Hz

# LARGE ALUMINUM ELECTROLYTIC CAPACITORS

**HJ** series

● DIMENSIONS & MAXIMUM PERMISSIBLE RIPPLE CURRENT

WV μF / ØD	160				200				250			
	22	25.4	30	35	22	25.4	30	35	22	25.4	30	35
220					22×20 1.18				22×25 1.24	25.4×20 1.22		
270	22×20 1.30				22×25 1.37	25.4×20 1.35			22×25 1.50	25.4×25 1.32		
330	22×25 1.50				22×25 1.51	25.4×20 1.49			22×30 1.66	25.4×25 1.61	30×20 1.58	
390	22×25 1.63	25.4×20 1.62			22×25 1.73	25.4×25 1.71	30×20 1.71		22×35 1.88	25.4×30 1.88	30×25 1.86	
470	22×30 1.86	25.4×20 1.86			22×30 1.97	25.4×25 1.95	30×20 1.88		22×35 2.15	25.4×35 2.15	30×25 2.04	
560	22×30 2.15	25.4×25 2.15	30×20 2.05		22×35 2.18	25.4×30 2.15	30×25 2.15		22×40 2.48	25.4×35 2.35	30×25 2.35	35×25 2.35
680	22×35 2.35	25.4×30 2.33	30×25 2.33		22×40 2.48	25.4×30 2.48	30×25 2.48	35×25 2.33	22×50 2.61	25.4×40 2.67	30×30 2.71	35×25 2.58
820	22×40 2.68	25.4×30 2.65	30×25 2.64		22×45 2.81	25.4×35 2.79	30×30 2.80	35×25 2.83		25.4×45 3.01	30×35 2.98	35×30 2.96
1000	22×45 3.02	25.4×35 3.00	30×30 2.96	35×25 3.13	22×50 3.28	25.4×40 3.28	30×35 3.15	35×30 3.26			30×40 3.56	35×35 3.48
1200	22×50 3.47	25.4×40 3.43	30×30 3.41	35×25 3.40		25.4×45 3.61	30×35 3.61	35×30 3.57			30×45 3.99	35×35 3.84
1500		25.4×45 3.96	30×35 3.96	35×30 3.94			30×45 4.13	35×35 4.06			30×50 4.33	35×40 4.33
1800			30×40 4.31	35×35 4.28			30×50 4.60	35×40 4.59				35×50 4.76
2200			30×50 4.96	35×40 4.96				35×45 5.25				

WV μF / ØD	350				400				450			
	22	25.4	30	35	22	25.4	30	35	22	25.4	30	35
68					22×20 0.65				22×20 0.71			
82					22×20 0.85				22×25 0.86	25.4×20 0.84		
100	22×20 0.80				22×25 0.99	25.4×20 0.82			22×25 0.95	25.4×25 0.97		
120	22×25 1.04	25.4×20 1.05			22×25 1.09	25.4×20 1.13			22×30 1.07	25.4×25 1.09	30×20 1.12	
150	22×25 1.20	25.4×25 1.22			22×30 1.24	25.4×25 1.27	30×20 1.20		22×35 1.18	25.4×30 1.25	30×25 1.29	
180	22×30 1.34	25.4×25 1.37			22×30 1.41	25.4×25 1.44	30×25 1.52		22×35 1.32	25.4×35 1.40	30×25 1.45	
220	22×30 1.47	25.4×30 1.53	30×25 1.54		22×35 1.58	25.4×30 1.64	30×25 1.66		22×40 1.48	25.4×35 1.59	30×25 1.64	35×25 1.59
270	22×35 1.70	25.4×30 1.73	30×25 1.80		22×40 1.65	25.4×35 1.79	30×30 1.82	35×25 1.63	22×50 1.88	25.4×40 1.87	30×30 1.89	35×25 1.90
330	22×45 1.87	25.4×35 1.97	30×30 2.03	35×25 1.80	22×50 1.95	25.4×40 2.00	30×30 2.05	35×25 2.05		25.4×45 2.12	30×35 2.12	35×30 2.15
390	22×50 2.08	25.4×40 2.14	30×30 2.23	35×25 2.30		25.4×45 2.12	30×35 2.26	35×30 2.28			30×40 2.30	35×35 2.35
470		25.4×45 2.55	30×35 2.53	35×30 2.55		25.4×50 2.46	30×40 2.51	35×30 2.51			30×45 2.68	35×35 2.68
560		25.4×50 2.70	30×40 2.73	35×35 2.75			30×45 2.85	35×35 2.85				35×40 2.88
680			30×45 3.15	35×35 3.15			30×50 3.01	35×40 3.01				35×50 3.44
820				35×40 3.47								

← Case size ØD×L (mm)  
← Ripple current (Arms) at 85°C, 120Hz

WV μF / ØD	500			
	22	25.4	30	35
56	22×20 0.50			
68	22×25 0.59	25.4×20 0.59		
82	22×30 0.68	25.4×25 0.65		
100	22×35 0.79	25.4×30 0.82	30×25 0.82	
120	22×40 0.94	25.4×35 0.94	30×25 0.95	
150	22×45 1.09	25.4×35 1.10	30×30 1.13	
180	22×50 1.27	25.4×40 1.30	30×35 1.30	35×25 1.27
220		25.4×45 1.50	30×40 1.50	35×30 1.48
270			30×45 1.81	35×35 1.72
330				35×40 1.99
390				35×45 2.34
470				35×50 2.81

## HF Snap-in Terminal Type, Long life Series

- Long life than HJ series
- Load life at 5000 hours at 85°C
- Complied to the RoHS directive

HJ  $\Rightarrow$  HF  
Long life

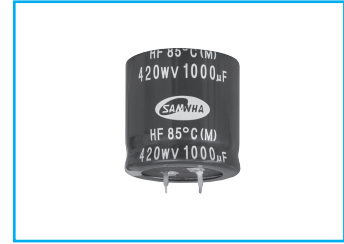

Item	Characteristics													
Operating temperature range	WV<350 : -40 ~ +85°C, WV ≥ 350 : -25 ~ +85°C													
Capacitance tolerance	±20% at 120Hz, 20°C													
Leakage current max.	$I=3\sqrt{CV}$ (µA) (after 5 minutes)													
Dissipation factor max. (at 120Hz, 20°C)	Capacitance > 1000µF : tanδ increases by 0.01 for each 1000µF from below value.													
	<table border="1"> <thead> <tr> <th>WV</th> <th>160</th> <th>200</th> <th>250</th> <th>350</th> <th>400</th> <th>450</th> </tr> </thead> <tbody> <tr> <td>tanδ</td> <td>0.15</td> <td>0.15</td> <td>0.15</td> <td>0.15</td> <td>0.15</td> <td>0.20</td> </tr> </tbody> </table>	WV	160	200	250	350	400	450	tanδ	0.15	0.15	0.15	0.15	0.15
WV	160	200	250	350	400	450								
tanδ	0.15	0.15	0.15	0.15	0.15	0.20								
Load life (after application of the rated voltage for 5000 hours at 85°C)	Leakage current	Less than specified value												
	Capacitance change	Within ±20% of initial value												
	tanδ	Less than 200% of specified value												
Shelf life (at 85°C)	After 1000 hours no load test, leakage current, capacitance and tanδ are same as load life value. The measurement shall be performed at 20°C by the KS C IEC 60384 - 4													

### ● DRAWING

Unit : mm

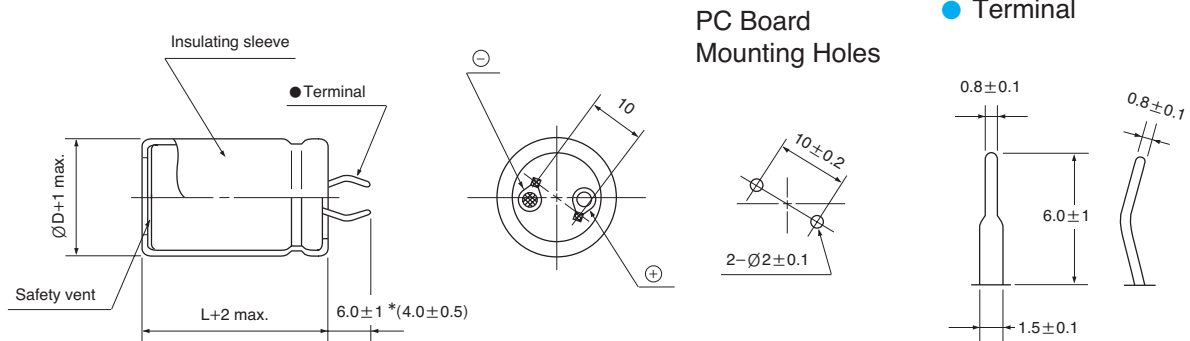

\* Shorter terminal ( $4.0 \pm 0.5$ ) is also available upon request.  
Terminal length of height 20mm products is applied shorter terminal to standard terminal type.

### ● FREQUENCY COEFFICIENT OF PERMISSIBLE RIPPLE CURRENT

WV	Frequency	50Hz	120Hz	300Hz	1kHz	10kHz ≤
160 ~ 250	50Hz	0.85	1.00	1.20	1.25	1.45
	120Hz	0.85	1.00	1.15	1.20	1.40

# LARGE ALUMINUM ELECTROLYTIC CAPACITORS

## HF series

### ● DIMENSIONS & MAXIMUM PERMISSIBLE RIPPLE CURRENT

WV μF ∅D	160				200				250			
	22	25.4	30	35	22	25.4	30	35	22	25.4	30	35
150									22×20 0.97			
180					22×20 0.91				22×20 1.06			
220					22×20 1.18				22×25 1.24	25.4×20 1.22		
270	22×20 1.30				22×25 1.37	25.4×20 1.35			22×25 1.50	25.4×25 1.32		
330	22×25 1.50				22×25 1.51	25.4×20 1.49			22×30 1.66	25.4×25 1.61	30×20 1.58	
390	22×25 1.63	25.4×20 1.62			22×25 1.73	25.4×25 1.71	30×20 1.71		22×35 1.88	25.4×30 1.88	30×25 1.86	
470	22×30 1.86	25.4×20 1.86			22×30 1.97	25.4×25 1.95	30×20 1.88		22×35 2.15	25.4×35 2.15	30×25 2.04	
560	22×30 2.15	25.4×25 2.15	30×20 2.05		22×35 2.18	25.4×30 2.15	30×25 2.15		22×40 2.48	25.4×35 2.35	30×25 2.35	35×25 2.35
680	22×35 2.35	25.4×30 2.33	30×25 2.33		22×40 2.48	25.4×30 2.48	30×25 2.48	35×25 2.33	22×50 2.61	25.4×40 2.67	30×30 2.71	35×25 2.58
820	22×40 2.68	25.4×30 2.65	30×25 2.64		22×45 2.81	25.4×35 2.79	30×30 2.80	35×25 2.83		25.4×45 3.01	30×35 2.98	35×30 2.96
1000	22×45 3.02	25.4×35 3.00	30×30 2.96	35×25 3.13	22×50 3.28	25.4×40 3.28	30×35 3.15	35×30 3.26			30×40 3.56	35×35 3.48
1200	22×50 3.47	25.4×40 3.43	30×30 3.41	35×25 3.40		25.4×45 3.61	30×35 3.61	35×30 3.57			30×45 3.99	35×35 3.84
1500		25.4×45 3.96	30×35 3.96	35×30 3.94			30×45 4.13	35×35 4.06			30×50 4.33	35×40 4.33
1800			30×40 4.31	35×35 4.28			30×50 4.60	35×40 4.59				35×50 4.76
2200			30×50 4.96	35×40 4.96				35×45 5.25				
2700				35×45 5.57								
3300				35×50 6.21								

WV μF ∅D	350				400				450			
	22	25.4	30	35	22	25.4	30	35	22	25.4	30	35
56									22×20 0.61			
68					22×20 0.65				22×20 0.71			
82					22×20 0.85				22×25 0.86	25.4×20 0.84		
100	22×20 0.80				22×25 0.99	25.4×20 0.82			22×25 0.95	25.4×25 0.97		
120	22×25 1.04	25.4×20 0.90			22×25 1.09	25.4×20 1.13			22×30 1.07	25.4×25 1.09	30×20 1.12	
150	22×25 1.20	25.4×25 1.22			22×30 1.24	25.4×25 1.27	30×20 1.20		22×35 1.18	25.4×30 1.25	30×25 1.29	
180	22×30 1.34	25.4×25 1.37			22×30 1.41	25.4×25 1.44	30×25 1.52		22×35 1.32	25.4×35 1.40	30×25 1.45	
220	22×30 1.47	25.4×30 1.53	30×25 1.54		22×35 1.58	25.4×30 1.64	30×25 1.66		22×40 1.48	25.4×35 1.59	30×25 1.64	35×25 1.59
270	22×35 1.70	25.4×30 1.73	30×25 1.80		22×40 1.65	25.4×35 1.79	30×30 1.82	35×25 1.63	22×50 1.88	25.4×40 1.87	30×30 1.89	35×25 1.90
330	22×45 1.87	25.4×35 1.97	30×30 2.03	35×25 1.80	22×50 1.95	25.4×40 2.00	30×30 2.05	35×25 2.05		25.4×45 2.12	30×35 2.12	35×30 2.15
390	22×50 2.08	25.4×40 2.14	30×30 2.23	35×25 2.30		25.4×45 2.12	30×35 2.26	35×30 2.28			30×40 2.23	35×35 2.29
470		25.4×45 2.55	30×35 2.53	35×30 2.55		25.4×50 2.46	30×40 2.51	35×30 2.51			30×45 2.68	35×35 2.68
560		25.4×50 2.64	30×40 2.73	35×35 2.75			30×45 2.85	35×35 2.85				35×40 2.88
680			30×45 3.15	35×35 3.15			30×50 3.01	35×40 3.01				35×50 3.44
820				35×40 3.47				35×50 3.31	← Case size ∅D × L (mm) ← Ripple current (Arms) at 85°C, 120Hz			
1000				35×45 3.65								

## JR Snap-in Terminal Type, Long Life Series

- Long life than HF series
- Load life of 10000 hours at 85°C
- Complied to the RoHS directive

HF  $\Rightarrow$  JR  
Long life



Item	Characteristics		
Operating temperature range	-25 ~ +85°C		
Capacitance tolerance	±20% at 120Hz, 20°C		
Leakage current max.	$I=3\sqrt{CV}$ (µA) (after 5 minutes)		
Dissipation factor max. (120Hz, 20°C)	WV	400	450
	tanδ	0.15	0.20
Load life (after application of the rated voltage for 10000 hours at 85°C)	Leakage current	Less than specified value	
	Capacitance change	Within ±20% of initial value	
	tanδ	Less than 200% of specified value	
Shelf life (at 85°C)	After 1000 hours no load test, leakage current, capacitance and tanδ are same as load life value. The measurement shall be performed at 20°C by the KS C IEC 60384 - 4		

● DRAWING (See page 177)

● DIMENSIONS & MAXIMUM PERMISSIBLE RIPPLE CURRENT

WV µF	400				450			
	22	25.4	30	35	22	25.4	30	35
56	22 × 20 0.68				22 × 25 0.70	25.4 × 20 0.71		
68	22 × 20 0.75	25.4 × 20 0.74			22 × 25 0.82	25.4 × 25 0.84	30 × 20 0.97	
82	22 × 25 0.98	25.4 × 25 0.82	30 × 20 0.97		22 × 30 0.99	25.4 × 25 0.97	30 × 20 1.09	
100	22 × 25 1.14	25.4 × 25 0.94	30 × 20 1.09		22 × 30 1.09	25.4 × 25 1.12	30 × 25 1.12	
120	22 × 30 1.25	25.4 × 30 1.30	30 × 25 1.21		22 × 35 1.23	25.4 × 30 1.25	30 × 25 1.29	35 × 20 1.28
150	22 × 35 1.43	25.4 × 30 1.46	30 × 25 1.38		22 × 45 1.36	25.4 × 30 1.44	30 × 25 1.48	35 × 25 1.40
180	22 × 40 1.62	25.4 × 40 1.66	30 × 30 1.75	35 × 25 1.51		25.4 × 35 1.61	30 × 30 1.67	35 × 25 1.54
220	22 × 45 1.82	25.4 × 40 1.89	30 × 30 1.91	35 × 30 1.63		25.4 × 40 1.83	30 × 30 1.89	35 × 30 1.68
270		25.4 × 45 2.06	30 × 35 2.09	35 × 30 1.87			30 × 35 2.17	35 × 30 1.83
330		25.4 × 50 2.30	30 × 40 2.36	35 × 35 2.36			30 × 40 2.44	35 × 35 2.19
390		25.4 × 60 2.44	30 × 50 2.60	35 × 40 2.62			30 × 50 2.56	35 × 40 2.47
470			30 × 50 2.89	35 × 40 2.89				35 × 40 2.63
560				35 × 45 3.28				35 × 45 3.31
680				35 × 50 3.46	← Case size ØD×L (mm) ← Ripple current (A rms) at 85°C, 120Hz			

● FREQUENCY COEFFICIENT OF PERMISSIBLE RIPPLE CURRENT

WV	Frequency	50Hz	120Hz	300Hz	1kHz	10kHz ≤
400, 450		0.85	1.00	1.15	1.20	1.40

# LARGE ALUMINUM ELECTROLYTIC CAPACITORS

Upgrade

# HE

Wide Temperature Range, Standard Series



Solvent Proof  
WV ≤ 100V



- Wide temperature range of -40(-25) ~ +105°C
- Standard snap-in terminal type
- Complied to the RoHS directive



Item	Characteristics															
Operating temperature range	WV < 350 : -40 ~ +105°C, WV ≥ 350 : -25 ~ +105°C															
Capacitance tolerance	± 20% at 120Hz, 20°C															
Leakage current max.	$I = 3\sqrt{CV}$ (µA) (after 5 minutes)															
Dissipation factor max. (at 120Hz, 20°C)	Capacitance > 1000µF : tanδ increases by 0.01 for each 1000µF from below value.															
	<table border="1"> <thead> <tr> <th>WV</th> <th>6.3, 10</th> <th>16</th> <th>25, 35</th> <th>50, 63</th> <th>80, 100</th> <th>160 ~ 400</th> <th>450 ~ 600</th> </tr> </thead> <tbody> <tr> <td>tanδ</td> <td>0.50</td> <td>0.40</td> <td>0.35</td> <td>0.25</td> <td>0.20</td> <td>0.15</td> <td>0.20</td> </tr> </tbody> </table>	WV	6.3, 10	16	25, 35	50, 63	80, 100	160 ~ 400	450 ~ 600	tanδ	0.50	0.40	0.35	0.25	0.20	0.15
WV	6.3, 10	16	25, 35	50, 63	80, 100	160 ~ 400	450 ~ 600									
tanδ	0.50	0.40	0.35	0.25	0.20	0.15	0.20									
Load life (after application of the rated voltage for 2000 hours at 105°C)	Leakage current	Less than specified value														
	Capacitance change	Within ± 20% of initial value														
	tanδ	Less than 200% of specified value (600Vdc : ≤ 300%)														
Shelf life (at 105°C)	After 1000 hours no load test, leakage current, capacitance and tanδ are same as load life value. The measurement shall be performed at 20°C by the KS C IEC 60384 - 4															

## ● DRAWING

Unit : mm

### ● ØD ≤ 40

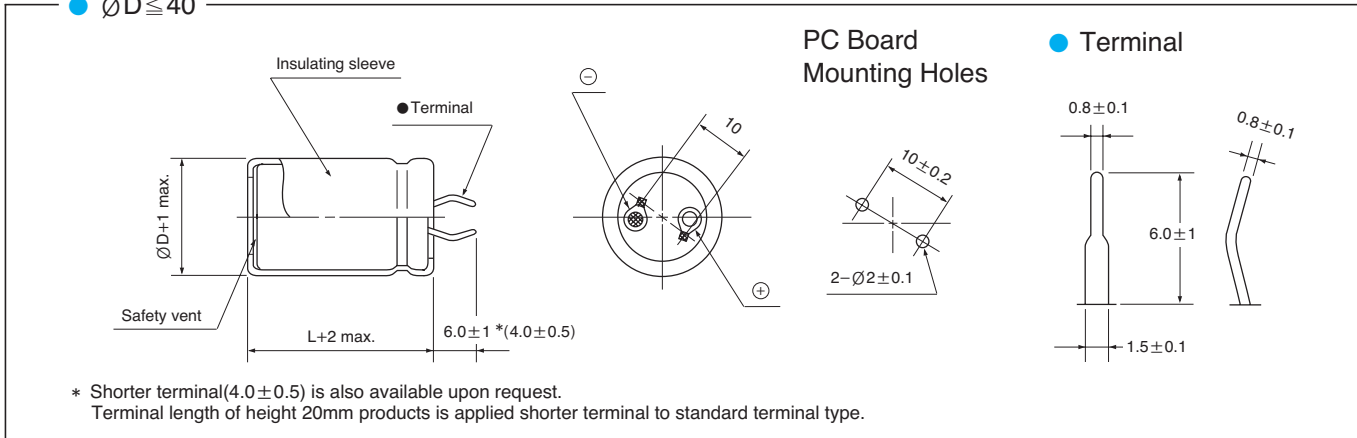

### ● ØD=35, 40

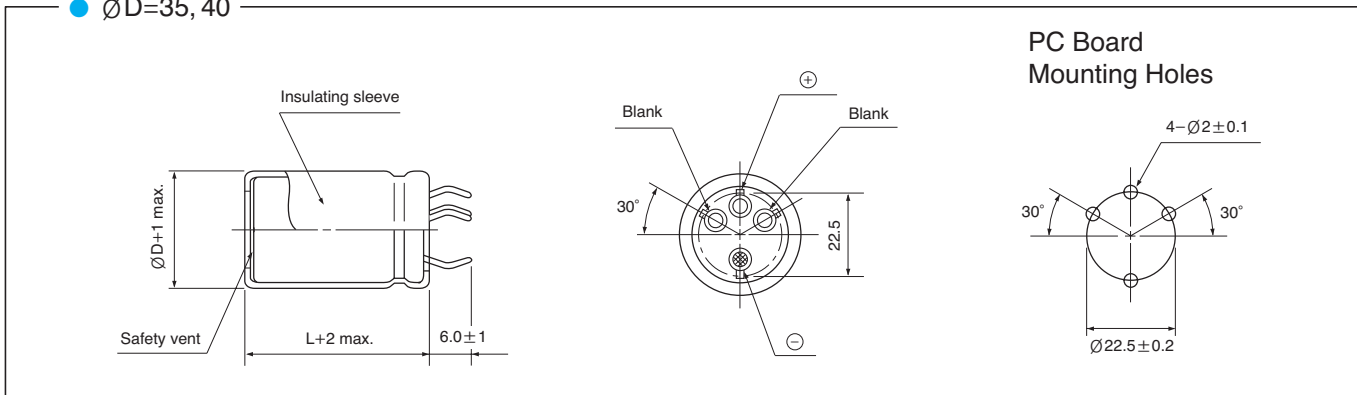

## ● FREQUENCY COEFFICIENT OF PERMISSIBLE RIPPLE CURRENT

WV	Frequency(Hz)	50Hz	120Hz	300Hz	1kHz	10kHz ≤
~ 100		0.85	1.00	1.06	1.15	1.20
160 ~ 250		0.85	1.00	1.20	1.25	1.45
315 ~		0.85	1.00	1.15	1.20	1.40

## HE series

### ● DIMENSIONS & MAXIMUM PERMISSIBLE RIPPLE CURRENT

WV μF / ØD	6.3					10					16				
	22	25.4	30	35	40	22	25.4	30	35	40	22	25.4	30	35	40
8200											22×25 2.14				
10000						22×25 2.17					22×30 2.48	25.4×25 2.56			
12000	22×25 2.19					22×30 2.48					22×35 2.80	25.4×30 2.90	30×25 2.97		
15000	22×30 2.53					22×35 2.83	25.4×25 2.75				22×40 3.17	25.4×35 3.29	30×30 3.38		
18000	22×35 2.85	25.4×25 2.77				22×35 3.00	25.4×30 3.11				22×45 3.50	25.4×40 3.65	30×30 3.57		
22000	22×35 3.04	25.4×30 3.15				22×40 3.35	25.4×35 3.48	30×25 3.38				25.4×45 4.03	30×35 3.98		
27000	22×40 3.40	25.4×35 3.53	30×25 3.42			22×50 3.88	25.4×40 3.87	30×30 3.79				25.4×50 4.42	30×40 4.39	35×30 4.29	
33000	22×50 3.92	25.4×40 3.91	30×30 3.83				25.4×45 4.26	30×35 4.20					30×45 4.79	35×35 4.71	
39000		25.4×45 4.26	30×35 4.20				25.4×50 4.60	30×40 4.57	35×30 4.46				30×50 5.16	35×40 5.10	
47000		25.4×50 4.63	30×40 4.60	35×30 4.50				30×45 4.95	35×35 4.87					35×45 5.50	40×40 5.60
56000			30×50 5.17	35×40 5.12					35×45 5.49	40×40 5.59					40×50 6.22
68000				35×45 5.52	40×40 5.62					40×50 6.22					40×60 6.83

WV μF / ØD	25					35					50				
	22	25.4	30	35	40	22	25.4	30	35	40	22	25.4	30	35	40
2700											22×30 1.94				
3300						22×25 1.62					22×35 2.20				
3900						22×30 1.88					22×40 2.52	25.4×35 2.62	30×25 2.54		
4700	22×25 1.73					22×35 2.14	25.4×25 2.09				22×45 2.81	25.4×40 2.93	30×30 2.87		
5600	22×30 1.98					22×35 2.29	25.4×30 2.37	30×25 2.43			22×50 3.11	25.4×40 3.11	30×35 3.21		
6800	22×30 2.14					22×40 2.61	25.4×35 2.71	30×30 2.79				25.4×50 3.64	30×40 3.61	35×30 3.53	
8200	22×35 2.42	25.4×30 2.50				22×50 3.02	25.4×40 3.02	30×30 2.95					30×45 3.94	35×35 3.87	
10000	22×40 2.77	25.4×35 2.88					25.4×45 3.43	30×35 3.38					30×50 4.42	35×40 4.37	
12000	22×45 3.09	25.4×40 3.22	30×30 3.15				25.4×50 3.78	30×40 3.75	35×30 3.67					35×45 4.78	
15000		25.4×45 3.62	30×35 3.57	35×30 3.65				30×45 4.19	35×35 4.12					35×50 5.24	40×40 5.13
18000		25.4×50 3.98	30×40 3.95	35×35 4.06					35×40 4.52						40×50 5.76
22000			30×45 4.36	35×35 4.28					35×45 4.95	40×40 5.04					40×50 5.98
27000				35×45 4.92	40×40 5.01					40×50 5.92					40×60 6.61

WV μF / ØD	63					80					100				
	22	25.4	30	35	40	22	25.4	30	35	40	22	25.4	30	35	40
820						22×25 1.37					22×30 1.46	25.4×25 1.51			
1000						22×30 1.62	25.4×25 1.67				22×35 1.71	25.4×30 1.77			
1200	22×25 1.37					22×30 1.67	25.4×25 1.72				22×40 1.86	25.4×35 1.94	30×25 1.88		
1500	22×30 1.50	25.4×25 1.54				22×35 1.98	25.4×30 2.05				22×45 2.18	25.4×40 2.28	30×30 2.23		
1800	22×30 1.64	25.4×25 1.69				22×40 2.28	25.4×35 2.37	30×25 2.30				25.4×45 2.61	30×35 2.57		
2200	22×35 1.86	25.4×30 1.92				22×45 2.51	25.4×35 2.49	30×30 2.56				25.4×50 2.85	30×40 2.76	35×30 2.70	
2700	22×40 2.17	25.4×30 2.13	30×25 2.18				25.4×45 3.03	30×35 2.99					30×45 3.27	35×35 3.22	
3300	22×50 2.53	25.4×40 2.53	30×30 2.48				25.4×50 3.33	30×40 3.30	35×30 3.23				30×50 3.59	35×40 3.55	
3900		25.4×45 2.88	30×35 2.84					30×45 3.75	35×35 3.69					35×45 4.03	
4700		25.4×50 3.20	30×40 3.17	35×30 3.10				30×50 4.10	35×40 4.06					35×50 4.40	40×40 4.31
5600			30×45 3.51	35×35 3.46					35×45 4.44						40×50 4.88
6800			30×50 3.92	35×40 3.88					35×50 4.90	40×40 4.80					40×50 5.18
8200				35×45 4.22						40×50 5.32	← Case size ØD×L (mm) ← Ripple current (Arms) at 105°C, 120Hz				
10000				35×50 4.74	40×40 4.64										



# LARGE ALUMINUM ELECTROLYTIC CAPACITORS

**HE** series

● DIMENSIONS & MAXIMUM PERMISSIBLE RIPPLE CURRENT

WV μF / ØD	160					200					250				
	22	25.4	30	35	40	22	25.4	30	35	40	22	25.4	30	35	40
150						22×20 0.63					22×20 0.68	25.4×20 0.69			
180	22×20 0.69					22×20 0.69					22×25 0.74	25.4×20 0.76	30×20 0.83		
220	22×20 0.76					22×25 0.82	25.4×20 0.84				22×25 0.88	25.4×25 0.90	30×20 0.92		
270	22×25 0.91	25.4×20 0.93				22×25 0.91	25.4×25 1.00	30×20 1.02			22×30 1.03	25.4×25 1.06	30×25 1.09		
330	22×25 1.01	25.4×25 1.10	30×20 1.13			22×30 1.07	25.4×25 1.11	30×20 1.13			22×35 1.20	25.4×30 1.18	30×25 1.21		
390	22×30 1.17	25.4×25 1.20	30×20 1.23			22×30 1.24	25.4×30 1.28	30×25 1.31			22×40 1.36	25.4×35 1.42	30×25 1.39	35×25 1.42	
470	22×30 1.36	25.4×25 1.32	30×25 1.44			22×35 1.43	25.4×30 1.48	30×25 1.44	35×25 1.56		22×45 1.56	25.4×35 1.56	30×30 1.53	35×25 1.56	
560	22×35 1.56	25.4×30 1.53	30×25 1.57	35×25 1.70		22×45 1.63	25.4×35 1.62	30×30 1.67	35×25 1.70			25.4×40 1.86	30×30 1.76	35×30 1.80	
680	22×40 1.80	25.4×35 1.79	30×25 1.73	35×25 1.88		22×50 1.88	25.4×40 1.96	30×30 1.84	35×25 1.88				30×35 2.12	35×35 2.09	
820		25.4×40 2.06	30×30 2.02	35×25 2.06			25.4×45 2.25	30×35 2.13	35×30 2.18				30×40 2.23	35×35 2.40	
1000		25.4×40 2.38	30×35 2.35	35×30 2.41				30×40 2.57	35×35 2.53					35×40 2.76	40×40 2.81
1200		25.4×50 2.52	30×40 2.50	35×30 2.44				30×50 2.72	35×35 2.57	40×40 2.85				35×45 2.91	40×50 3.08
1500				35×40 3.00	40×40 3.19				35×45 3.13	40×50 3.44					40×60 3.68

WV μF / ØD	315					350					400				
	22	25.4	30	35	40	22	25.4	30	35	40	22	25.4	30	35	40
56											22×20 0.37				
68						22×20 0.41					22×20 0.44	25.4×20 0.45			
82	22×20 0.45					22×25 0.48	25.4×20 0.49				22×25 0.48	25.4×25 0.53	30×20 0.54		
100	22×25 0.53	25.4×20 0.55				22×25 0.53	25.4×25 0.59	30×20 0.60			22×25 0.56	25.4×25 0.58	30×20 0.60		
120	22×30 0.62	25.4×25 0.64	30×20 0.65			22×30 0.62	25.4×25 0.64	30×20 0.65			22×30 0.66	25.4×30 0.68	30×25 0.70		
150	22×30 0.74	25.4×25 0.76	30×20 0.73			22×35 0.78	25.4×30 0.76	30×25 0.78			22×35 0.77	25.4×30 0.75	30×25 0.78		
180	22×35 0.85	25.4×30 0.88	30×25 0.86			22×40 0.89	25.4×35 0.88	30×30 0.91			22×40 0.89	25.4×40 0.93	30×30 0.91	35×25 0.93	
220	22×40 0.98	25.4×35 0.98	30×25 0.98			22×50 1.03	25.4×40 1.03	30×30 1.00	35×25 1.03		22×45 1.02	25.4×40 1.01	30×30 1.00	35×30 1.08	
270		25.4×40 1.19	30×30 1.12	35×25 1.14			25.4×45 1.19	30×35 1.17	35×30 1.20			25.4×45 1.17	30×35 1.17	35×30 1.20	
330		25.4×40 1.24	30×35 1.36	35×30 1.33			25.4×50 1.35	30×40 1.36	35×30 1.36			25.4×50 1.35	30×40 1.36	35×35 1.40	
390			30×35 1.47	35×30 1.52			25.4×50 1.47	30×40 1.54	35×35 1.54			25.4×60 1.54	30×50 1.61	35×40 1.59	
470			30×40 1.70	35×35 1.74					35×40 1.74				30×50 1.76	35×40 1.82	40×40 1.85
560			30×45 1.90	35×40 1.90					35×45 2.06	40×40 2.02				35×45 2.06	40×50 2.18
680			30×50 2.12	35×45 2.18	40×40 2.23					40×50 2.40				35×50 2.27	40×60 2.57

WV μF / ØD	450				500				550				600	
	22	25.4	30	35	22	25.4	30	35	22	25.4	30	35	30	35
47	22×20 0.34				22×25 0.32	25.4×20 0.32			22×25 0.35					
56	22×25 0.40	25.4×20 0.41			22×30 0.37	25.4×25 0.38	30×20 0.40		22×30 0.41	25.4×25 0.42				
68	22×25 0.44	25.4×25 0.48	30×20 0.49		22×30 0.50	25.4×25 0.42	30×25 0.47		22×35 0.48	25.4×30 0.49	30×25 0.51			
82	22×30 0.51	25.4×25 0.52	30×20 0.54		22×35 0.53	25.4×30 0.61	30×25 0.52		22×40 0.55	25.4×35 0.57	30×25 0.56			
100	22×30 0.56	25.4×25 0.58	30×25 0.64		22×35 0.55	25.4×35 0.70	30×25 0.56	35×25 0.61	22×45 0.64	25.4×40 0.66	30×30 0.66	35×25 0.67		
120	22×35 0.66	25.4×30 0.67	30×25 0.70	35×20 0.76	22×40 0.66	25.4×35 0.71	30×30 0.80	35×30 0.71	22×50 0.73	25.4×40 0.72	30×35 0.75	35×30 0.75	30×40 0.96	35×30 0.95
150	22×45 0.80	25.4×30 0.77	30×25 0.83	35×25 0.85		25.4×40 0.81	30×30 0.82	35×30 0.79		25.4×50 0.88	30×40 0.88	35×30 0.88	30×45 1.10	35×35 1.07
180		25.4×35 0.93	30×30 0.90	35×25 0.98		25.4×45 0.86	30×40 1.02	35×30 1.05			30×45 1.00	35×35 1.01	30×50 1.22	35×40 1.22
220		25.4×40 1.08	30×30 1.06	35×30 1.08			30×40 1.12	35×35 1.08			30×50 1.15	35×40 1.15	30×60 1.40	35×45 1.38
270			30×35 1.23	35×30 1.26			30×50 1.18	35×40 1.24				35×45 1.32		35×50 1.56
330			30×40 1.42	35×35 1.46				35×45 1.42				35×50 1.58		35×60 1.79
390			30×50 1.60	35×40 1.66				35×50 1.62				35×60 1.78		
470				35×40 1.81				35×55 1.71						
560				35×45 2.06										

← Case size ØD × L (mm)  
← Ripple current (Arms) at 105°C, 120Hz

# LARGE ALUMINUM ELECTROLYTIC CAPACITORS



## JK For Printer system

- For printer system
- No sparks DC overvoltage



Item	Characteristics		
Operating temperature range	WV<350 : -40 ~ +105°C, WV≥350 : -25 ~ +105°C		
Capacitance tolerance	±20% at 120Hz, 20°C		
Leakage current max.	$I=3\sqrt{CV}$ (µA) (after 5 minutes)		
Dissipation factor max. (120Hz, 20°C)	WV	250, 400	450
	tanδ	0.15	0.20
Load life (after application of the rated voltage for 2000 hours at 105°C)	Leakage current	Less than specified value	
	Capacitance change	Within ±20% of initial value	
	tanδ	Less than 200% of specified value	
Shelf life (at 105°C)	After 1000 hours no load test, leakage current, capacitance and tanδ are same as load life value. The measurement shall be performed at 20°C by the KS C IEC 60384 - 4		

● DRAWING (See page 183)

● DIMENSIONS & MAXIMUM PERMISSIBLE RIPPLE CURRENT

WV µF	250			400			450		
	25.4	30	35	25.4	30	35	25.4	30	35
82				25.4 × 25 0.53	30 × 20 0.54		25.4 × 25 0.53	30 × 20 0.54	
100				25.4 × 30 0.62	30 × 20 0.60		25.4 × 25 0.58	30 × 25 0.64	
120				25.4 × 30 0.68	30 × 25 0.70		25.4 × 30 0.67	30 × 25 0.74	
150	25.4 × 20 0.69			25.4 × 35 0.81	30 × 30 0.83		25.4 × 35 0.85	30 × 30 0.88	35 × 25 0.85
180	25.4 × 20 0.76	30 × 20 0.83		25.4 × 40 0.93	30 × 30 0.91	35 × 25 0.93	25.4 × 40 0.97	30 × 30 0.96	35 × 30 0.98
220	25.4 × 25 0.90	30 × 20 0.92		25.4 × 45 1.07	30 × 35 1.05	35 × 30 1.08	25.4 × 50 1.32	30 × 30 1.40	35 × 30 1.43
270	25.4 × 30 1.06	30 × 25 1.09		25.4 × 50 1.24	30 × 40 1.23	35 × 30 1.20		30 × 35 1.43	35 × 35 1.45
330	25.4 × 30 1.18	30 × 25 1.21			30 × 45 1.42	35 × 35 1.40		30 × 45 1.48	35 × 35 1.49
390	25.4 × 35 1.42	30 × 30 1.39	35 × 25 1.42		30 × 50 1.61	35 × 40 1.59			35 × 40 1.59
470	25.4 × 35 1.48	30 × 30 1.53	35 × 25 1.56			35 × 45 1.82			35 × 50 1.89
560	25.4 × 40 1.65	30 × 30 1.67	35 × 25 1.72			35 × 50 2.06			
680		30 × 35 2.12	35 × 35 2.09						
820		30 × 40 2.23	35 × 40 2.40						
1000			35 × 45 2.76						
1200			35 × 45 2.91						
1500			35 × 45 3.13	← Case size ØD×L (mm) ← Ripple current (A rms) at 105°C, 120Hz					

● FREQUENCY COEFFICIENT OF PERMISSIBLE RIPPLE CURRENT

WV	Frequency	50Hz	120Hz	300Hz	1kHz	10kHz≤
250		0.85	1.00	1.20	1.25	1.45
400, 450		0.85	1.00	1.15	1.20	1.40

# LARGE ALUMINUM ELECTROLYTIC CAPACITORS

## HK Miniaturized Series

- Smaller case sizes than HE series
- Load life of 3000 hours at 105°C
- Complied to the RoHS directive

**S** Solvent Proof WV ≤ 100V  
**M** Miniaturized



HE → **HK** → HL  
 Long life      Long life

Item	Characteristics															
Operating temperature range	WV < 350 : -40 ~ +105°C, WV ≥ 350 : -25 ~ +105°C															
Capacitance tolerance	± 20% at 120Hz, 20°C															
Leakage current max.	$I = 3 \sqrt{CV}$ (µA) (after 5 minutes)															
Dissipation factor max. (at 120Hz, 20°C)	Capacitance > 1000µF : tanδ increases by 0.01 for each 1000µF from below value.															
	<table border="1"> <tr> <td>WV</td> <td>6.3, 10</td> <td>16</td> <td>25, 35</td> <td>50, 63</td> <td>80, 100</td> <td>160~400</td> <td>450, 500</td> </tr> <tr> <td>tanδ</td> <td>0.50</td> <td>0.40</td> <td>0.35</td> <td>0.25</td> <td>0.20</td> <td>0.15</td> <td>0.20</td> </tr> </table>	WV	6.3, 10	16	25, 35	50, 63	80, 100	160~400	450, 500	tanδ	0.50	0.40	0.35	0.25	0.20	0.15
WV	6.3, 10	16	25, 35	50, 63	80, 100	160~400	450, 500									
tanδ	0.50	0.40	0.35	0.25	0.20	0.15	0.20									
Load life (after application of the rated voltage for 3000 hours at 105°C)	Leakage current	Less than specified value														
	Capacitance change	Within ± 20% of initial value														
	tanδ	Less than 200% of specified value														
Shelf life (at 105°C)	After 1000 hours no load test, leakage current, capacitance and tanδ are same as load life value. The measurement shall be performed at 20°C by the KS C IEC 60384 - 4															

### ● DRAWING

Unit : mm

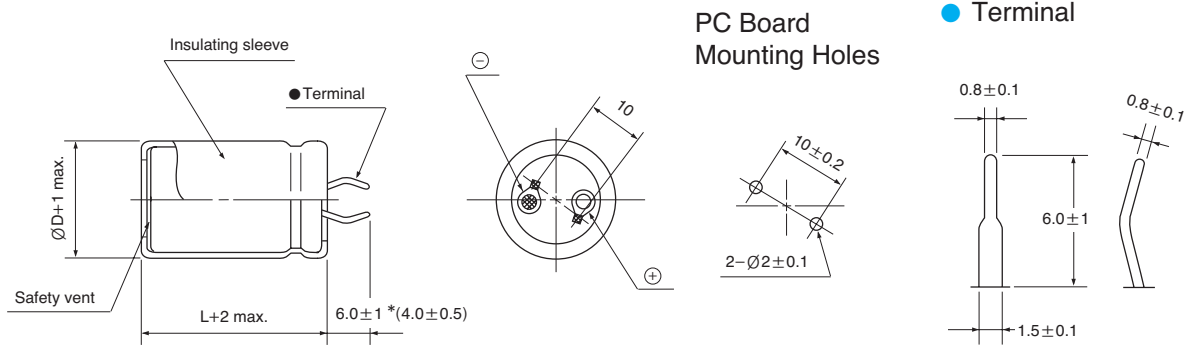

\* Shorter terminal(4.0 ± 0.5) is also available upon request.  
 Terminal length of height 20mm products is applied shorter terminal to standard terminal type.

### ● FREQUENCY COEFFICIENT OF PERMISSIBLE RIPPLE CURRENT

WV	Frequency	50Hz	120Hz	300Hz	1kHz	10kHz ≤
~ 100		0.85	1.00	1.06	1.15	1.20
160 ~ 250		0.85	1.00	1.20	1.25	1.45
350 ~		0.85	1.00	1.15	1.20	1.40

## HK series

### ● DIMENSIONS & MAXIMUM PERMISSIBLE RIPPLE CURRENT

WV μF / ØD	6.3					10					16				
	22	25.4	30	35	40	22	25.4	30	35	40	22	25.4	30	35	40
8200											22×25 2.14				
10000						22×25 2.17					22×30 2.48	25.4×25 2.56			
12000	22×25 2.19					22×30 2.48					22×35 2.80	25.4×30 2.90	30×25 2.97		
15000	22×30 2.53					22×35 2.83	25.4×25 2.75				22×40 3.17	25.4×35 3.29	30×30 3.38		
18000	22×35 2.85	25.4×25 2.77				22×35 3.00	25.4×30 3.11				22×45 3.50	25.4×40 3.65	30×30 3.57		
22000	22×35 3.04	25.4×30 3.15				22×40 3.35	25.4×35 3.48	30×25 3.38				25.4×45 4.03	30×35 3.98		
27000	22×40 3.40	25.4×35 3.53	30×25 3.42			22×50 3.88	25.4×40 3.87	30×30 3.79				25.4×50 4.42	30×40 4.39	35×30 4.29	
33000	22×50 3.92	25.4×40 3.91	30×30 3.83				25.4×45 4.26	30×35 4.20					30×45 4.79	35×35 4.71	
39000		25.4×45 4.26	30×35 4.20				25.4×50 4.60	30×40 4.57	35×30 4.46				30×50 5.16	35×40 5.10	
47000		25.4×50 4.63	30×40 4.60	35×30 4.50				30×45 4.95	35×35 4.87					35×45 5.50	40×40 5.60
56000			30×50 5.17	35×40 5.12					35×45 5.49	40×40 5.59					40×50 6.22
68000				35×45 5.52	40×40 5.62					40×50 6.22					40×60 6.83

WV μF / ØD	25					35					50				
	22	25.4	30	35	40	22	25.4	30	35	40	22	25.4	30	35	40
2700											22×30 1.94				
3300						22×25 1.62					22×35 2.20				
3900						22×30 1.88					22×40 2.52	25.4×35 2.62	30×25 2.54		
4700	22×25 1.73					22×35 2.14	25.4×25 2.09				22×45 2.81	25.4×40 2.93	30×30 2.87		
5600	22×30 1.98					22×35 2.29	25.4×30 2.37	30×25 2.43			22×50 3.11	25.4×40 3.11	30×35 3.21		
6800	22×30 2.14					22×40 2.61	25.4×35 2.71	30×30 2.79				25.4×50 3.64	30×40 3.61	35×30 3.53	
8200	22×35 2.42	25.4×30 2.50				22×50 3.02	25.4×40 3.02	30×30 2.95					30×45 3.94	35×35 3.87	
10000	22×40 2.77	25.4×35 2.88					25.4×45 3.43	30×35 3.38					30×50 4.42	35×40 4.37	
12000	22×45 3.09	25.4×40 3.22	30×30 3.15				25.4×50 3.78	30×40 3.75	35×30 3.67					35×45 4.78	
15000		25.4×45 3.62	30×35 3.57	35×30 3.65				30×45 4.19	35×35 4.12					35×50 5.24	40×40 5.13
18000		25.4×50 3.98	30×40 3.95	35×35 4.06					35×40 4.52						40×50 5.76
22000			30×45 4.36	35×35 4.28					35×45 4.95	40×40 5.04					40×50 5.98
27000				35×45 4.92	40×40 5.01					40×50 5.92					40×60 6.61

WV μF / ØD	63					80					100				
	22	25.4	30	35	40	22	25.4	30	35	40	22	25.4	30	35	40
820						22×25 1.37					22×30 1.46	25.4×25 1.51			
1000						22×30 1.62	25.4×25 1.67				22×35 1.71	25.4×30 1.77			
1200	22×25 1.37					22×30 1.67	25.4×25 1.72				22×40 1.86	25.4×35 1.94	30×25 1.88		
1500	22×30 1.50	25.4×25 1.54				22×35 1.98	25.4×30 2.05				22×45 2.18	25.4×40 2.28	30×30 2.23		
1800	22×30 1.64	25.4×25 1.69				22×40 2.28	25.4×35 2.37	30×25 2.30				25.4×45 2.61	30×35 2.57		
2200	22×35 1.86	25.4×30 1.92				22×45 2.51	25.4×35 2.49	30×30 2.56				25.4×50 2.85	30×40 2.83	35×30 2.76	
2700	22×40 2.17	25.4×30 2.13	30×25 2.18				25.4×45 3.03	30×35 2.99					30×45 3.27	35×35 3.22	
3300	22×50 2.53	25.4×40 2.53	30×30 2.48				25.4×50 3.33	30×40 3.30	35×30 3.23				30×50 3.59	35×40 3.55	
3900		25.4×45 2.88	30×35 2.84					30×45 3.75	35×35 3.69					35×45 4.03	
4700		25.4×50 3.20	30×40 3.17	35×30 3.10				30×50 4.10	35×40 4.06					35×50 4.40	40×40 4.31
5600			30×45 3.51	35×35 3.46					35×45 4.44					40×50 4.88	
6800			30×50 3.92	35×40 3.88					35×50 4.90	40×40 4.80				40×50 5.18	
8200				35×45 4.22						40×50 5.32					
10000				35×50 4.74	40×40 4.64										

← Case size ØD×L (mm)  
← Ripple current (Arms) at 105°C, 120Hz

# LARGE ALUMINUM ELECTROLYTIC CAPACITORS

**HK** series

● DIMENSIONS & MAXIMUM PERMISSIBLE RIPPLE CURRENT

WV μF / ØD	160				200				250			
	22	25.4	30	35	22	25.4	30	35	22	25.4	30	35
220									22×25 0.95			
270					22×25 1.05				22×25 1.17			
330	22×25 1.01				22×25 1.23				22×30 1.38	25.4×25 1.45		
390	22×25 1.09				22×30 1.55	25.4×25 1.59			22×35 1.58	25.4×30 1.62		
470	22×30 1.47				22×30 1.56	25.4×25 1.61			22×40 1.73	25.4×30 1.71	30×25 1.73	
560	22×30 1.70	25.4×25 1.76			22×35 1.79	25.4×30 1.76	30×25 1.81		22×45 1.89	25.4×35 1.96	30×30 1.93	
680	22×35 1.89	25.4×30 1.86			22×40 2.07	25.4×35 2.06	30×30 2.12			25.4×40 2.15	30×30 2.15	35×25 2.28
820	22×40 2.18	25.4×35 2.16				25.4×40 2.20	30×30 2.22	35×25 2.27			30×35 2.46	35×30 2.51
1000	22×45 2.51	25.4×40 2.51	30×30 2.45			25.4×45 2.55	30×35 2.60	35×30 2.67			30×40 2.79	35×35 2.78
1200		25.4×50 2.72	30×35 2.69	35×30 2.76			30×40 2.88	35×30 2.96			30×45 3.15	35×40 3.15
1500		25.4×50 3.18	30×40 3.15	35×30 3.08			30×45 3.32	35×35 3.41				35×45 3.78
1800			30×45 3.60	35×35 3.65			30×50 3.82	35×40 3.92				35×50 4.20
2200			30×50 4.13	35×40 4.10				35×50 4.35				
2700				35×50 4.61								

WV μF / ØD	350				400				450			
	22	25.4	30	35	22	25.4	30	35	22	25.4	30	35
68									22×20 0.47			
82					22×20 0.62				22×25 0.55			
100	22×25 0.58				22×25 0.74				22×25 0.72			
120	22×25 0.68				22×25 0.79				22×30 0.83	25.4×25 0.82		
150	22×25 0.76	25.4×25 0.81			22×30 0.94	25.4×25 0.91			22×35 0.92	25.4×25 0.90		
180	22×30 0.78	25.4×25 0.80			22×35 1.07	25.4×25 1.06			22×40 1.12	25.4×35 1.05	30×25 1.09	
220	22×35 0.93	25.4×30 0.95	30×25 0.96		22×40 1.18	25.4×30 1.18	30×25 1.20			25.4×35 1.18	30×30 1.20	
270	22×40 1.06	25.4×30 1.04	30×25 1.08			25.4×35 1.37	30×25 1.35			25.4×40 1.35	30×30 1.37	35×25 1.40
330	22×45 1.23	25.4×30 1.23	30×30 1.25	35×25 1.29		25.4×40 1.51	30×30 1.50	35×25 1.46			30×35 1.56	35×30 1.54
390		25.4×40 1.43	30×30 1.39	35×25 1.43			30×35 1.63	35×30 1.67			30×40 1.69	35×30 1.67
470		25.4×45 1.64	30×35 1.63	35×30 1.66			30×40 1.85	35×30 1.88				35×35 1.90
560			30×40 1.85	35×35 1.90				35×35 2.08				35×40 2.06
680			30×45 2.11	35×35 2.09				35×40 2.38				35×50 2.45
820				35×40 2.38				35×45 2.65				
1000				35×45 2.71								

WV μF / ØD	500			
	22	25.4	30	35
82	22×35 0.72	25.4×30 0.75		
100	22×40 0.83	25.4×35 0.82	30×25 0.84	
120	22×45 0.93	25.4×35 0.93	30×30 0.91	35×25 0.82
150		25.4×40 1.08	30×35 1.04	35×25 1.04
180		25.4×45 1.20	30×40 1.20	35×30 1.12
220			30×45 1.33	35×35 1.26
270			30×50 1.50	35×40 1.42
330			30×55 1.59	35×45 1.60
390				35×50 1.80
470				35×60 2.06

← Case size ØD×L (mm)  
← Ripple current (Arms) at 105°C, 120Hz

## HG High Ripple Series

- High ripple current compared with HK series
- Load life of 3000 hours at 105°C
- Complied to the RoHS directive

HK → **HG**  
High Ripple



Item	Characteristics			
Operating temperature range	WV<350 : -40 ~ +105°C, WV ≥350 : -25 ~ +105°C			
Capacitance tolerance	±20% at 120Hz, 20°C			
Leakage current max.	$I=3\sqrt{CV}$ (µA) (after 5 minutes)			
Dissipation factor max. (at 120Hz, 20°C)	Capacitance > 1000µF : tanδ increases by 0.01 for each 1000µF from below value.			
	WV	250	400	450
	tanδ	0.15	0.15	0.20
Load life (after application of the rated voltage for 3000 hours at 105°C)	Leakage current	Less than specified value		
	Capacitance change	Within ±20% of initial value		
	tanδ	Less than 200% of specified value		
Shelf life (at 105°C)	After 1000 hours no load test, leakage current, capacitance and tanδ are same as load life value. The measurement shall be performed at 20°C by the KS C IEC 60384 - 4			

### DRAWING

Unit : mm

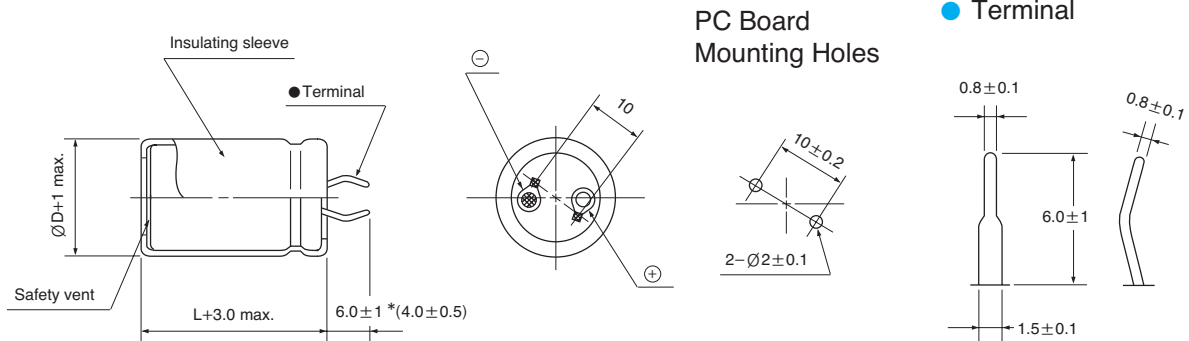

\* Shorter terminal(4.0±0.5) is also available upon request.  
Terminal length of height 20mm products is applied shorter terminal to standard terminal type.

### DIMENSIONS & MAXIMUM PERMISSIBLE RIPPLE CURRENT

WV µF	250				400				450			
	22	25.4	30	35	22	25.4	30	35	22	25.4	30	35
150									22×35 1.10	25.4×30 1.10		
180	22×20 0.88	25.4×20 0.89			22×35 1.26	25.4×25 1.25	30×20 1.29		22×40 1.32	25.4×35 1.32	30×25 1.29	35×25 1.32
220	22×25 0.93	25.4×20 1.06			22×40 1.46	25.4×30 1.47	30×25 1.43			25.4×35 1.52	30×30 1.50	35×25 1.46
330	22×30 1.35	25.4×25 1.39	30×20 1.43			25.4×40 1.95	30×30 1.93	35×25 1.89			30×35 2.03	35×30 2.20
470	22×40 1.78	25.4×30 1.74	30×25 1.80				30×40 2.20	35×30 2.48				35×40 2.59
560	22×45 2.02	25.4×35 2.01	30×25 1.98	35×25 2.01				35×35 2.82				35×45 2.93
680		25.4×40 2.43	30×30 2.29	35×25 2.34	← Case size ØD×L (mm)				35×40 3.24			35×50 3.43

↑ Ripple current (Arms) at 105°C, 120Hz

### FREQUENCY COEFFICIENT OF PERMISSIBLE RIPPLE CURRENT

WV	Frequency	50Hz	120Hz	300Hz	1kHz	10kHz ≤
250	50Hz	0.85	1.00	1.20	1.25	1.45
	120Hz	0.85	1.00	1.15	1.20	1.40

# LARGE ALUMINUM ELECTROLYTIC CAPACITORS

## KG Wide Temperature, High Ripple Series

- High ripple current compared with HG series
- Load life of 3000 hours at 105°C
- Complied to the RoHS directive



Item	Characteristics									
Operating temperature range	-40 ~ +105°C									
Capacitance tolerance	±20% at 120Hz, 20°C									
Leakage current max.	$I=3\sqrt{CV}$ (µA) (after 5 minutes)									
Dissipation factor max. (at 120Hz, 20°C)	Capacitance > 1000µF : tanδ increases by 0.01 for each 1000µF from below value.									
	<table border="1"> <thead> <tr> <th>WV</th> <th>400</th> <th>420</th> <th>450</th> <th>500</th> </tr> </thead> <tbody> <tr> <td>tanδ</td> <td>0.15</td> <td>0.20</td> <td>0.20</td> <td>0.20</td> </tr> </tbody> </table>	WV	400	420	450	500	tanδ	0.15	0.20	0.20
WV	400	420	450	500						
tanδ	0.15	0.20	0.20	0.20						
Load life (after application of the rated voltage for 3000 hours at 105°C)	Leakage current	Less than specified value								
	Capacitance change	Within ±20% of initial value								
	tanδ	Less than 200% of specified value								
Shelf life (at 105°C)	After 1000 hours no load test, leakage current, capacitance and tanδ are same as load life value. The measurement shall be performed at 20°C by the KS C IEC 60384 - 4									

● DRAWING (See page 183)

● DIMENSIONS & MAXIMUM PERMISSIBLE RIPPLE CURRENT

WV µF ∅D	400				420			
	22	25.4	30	35	22	25.4	30	35
100					22×30 0.79	25.4×25 0.77		
120	22×30 1.23	25.4×25 1.23			22×30 0.89	25.4×25 0.87		
150	22×35 1.34	25.4×30 1.31			22×35 1.10	25.4×30 1.09	30×25 1.17	
180	22×40 1.45	25.4×30 1.44	30×25 1.69		22×40 1.31	25.4×35 1.32	30×25 1.28	
220	22×45 1.58	25.4×35 1.69	30×30 1.80		22×50 1.63	25.4×40 1.57	30×30 1.55	35×25 1.43
270	22×50 1.78	25.4×40 1.88	30×35 2.08	35×25 2.13		25.4×45 1.82	30×35 1.84	35×30 1.74
330		25.4×50 2.15	30×40 2.33	35×30 2.35			30×40 2.12	35×30 1.86
390			30×45 2.53	35×35 2.54			30×45 2.45	35×35 2.42
470			30×50 2.86	35×40 2.86			30×50 2.76	35×45 2.70

WV µF ∅D	450				500			
	22	25.4	30	35	22	25.4	30	35
68					22×25 0.67			
82					22×30 0.77	25.4×25 0.79		
100	22×30 1.04	25.4×25 1.08			22×35 0.87	25.4×30 0.90		
120	22×35 1.17	25.4×30 1.18			22×40 0.98	25.4×30 0.98	30×25 0.99	
150	22×40 1.28	25.4×30 1.28	30×25 1.31		22×45 1.11	25.4×35 1.14	30×30 1.19	
180	22×45 1.46	25.4×40 1.43	30×30 1.63		22×50 1.24	25.4×40 1.28	30×30 1.22	35×25 1.19
220		25.4×40 1.68	30×30 1.68	35×25 1.61		25.4×50 1.46	30×35 1.39	35×30 1.34
270		25.4×50 2.08	30×35 1.89	35×30 2.14			30×40 1.58	35×35 1.51
330			30×45 2.24	35×35 2.56			30×50 1.83	35×40 1.73
390			30×50 2.52	35×40 2.74				35×45 1.91
470				35×45 3.06				35×50 2.15
560				35×50 3.11	← Case size ∅D×L (mm) ← Ripple current (Arms) at 105°C, 120Hz			35×60 2.43

● FREQUENCY COEFFICIENT OF PERMISSIBLE RIPPLE CURRENT

WV	Frequency	60Hz	120Hz	300Hz	1kHz	10kHz ≤
400 ~ 500		0.85	1.00	1.15	1.20	1.40

## HH Surge Voltage Series

- Surge voltage for household appliance
- Load life at 3000 hours at 105°C
- Complied to the RoHS directive

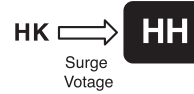

Item	Characteristics	
Operating temperature range	-25 ~ +105°C	
Capacitance tolerance	±20% at 120Hz, 20°C	
Leakage current max.	$I=3\sqrt{CV}$ (µA) (after 5 minutes)	
Dissipation factor max. (at 120Hz, 20°C)	WV	450
	tanδ	0.20
Load life (after application of the rated voltage for 3000 hours at 105°C)	Leakage current	Less than specified value
	Capacitance change	Within ±20% of initial value
	tanδ	Less than 200% of specified value
Shelf life (at 105°C)	After 1000 hours no load test, leakage current, capacitance and tanδ are same as load life value. The measurement shall be performed at 20°C by the KS C IEC 60384 - 4	

● DRAWING (See page 183)

● DIMENSIONS & MAXIMUM PERMISSIBLE RIPPLE CURRENT

WV µF	450			
	22	25.4	30	35
68	22 × 25 0.51			
82	22 × 25 0.69			
100	22 × 30 0.78	25.4 × 25 0.78		
120	22 × 35 0.86	25.4 × 30 0.88	30 × 25 0.87	
150	22 × 40 0.95	25.4 × 30 0.95	30 × 25 0.96	35 × 25 0.98
180		25.4 × 35 1.10	30 × 30 1.15	35 × 25 1.13
220		25.4 × 40 1.29	30 × 35 1.28	35 × 30 1.30
270		25.4 × 50 1.45	30 × 40 1.48	35 × 30 1.48
330			30 × 45 1.60	35 × 35 1.62
390			30 × 50 1.76	35 × 40 1.78
470				35 × 45 2.12
560				35 × 50 2.85

Case size ØD × L (mm) →  
 Ripple current (A rms) at 105°C, 120Hz →

● FREQUENCY COEFFICIENT OF PERMISSIBLE RIPPLE CURRENT

WV	Frequency	50Hz	120Hz	300Hz	1kHz	10kHz ≤
450		0.85	1.00	1.15	1.20	1.40



# LARGE ALUMINUM ELECTROLYTIC CAPACITORS

**HL** Long Life Series

- Long life than HK series
- Load life of 5000 hours at 105°C
- Complied to the RoHS directive

**S** Solvent Proof WV ≤ 100V  
**LL** Long Life



**HK** → **HL**  
 Long life

Item	Characteristics															
Operating temperature range	WV < 350 : -40 ~ +105°C, WV ≥ 350 : -25 ~ +105°C															
Capacitance tolerance	± 20% at 120Hz, 20°C															
Leakage current max.	$I = 3\sqrt{CV}$ (µA) (after 5 minutes)															
Dissipation factor max. (at 120Hz, 20°C)	Capacitance > 1000µF : tanδ increases by 0.01 for each 1000µF from below value.															
	<table border="1"> <thead> <tr> <th>WV</th> <th>10</th> <th>16</th> <th>25, 35</th> <th>50, 63</th> <th>80, 100</th> <th>160 ~ 400</th> <th>450, 500</th> </tr> </thead> <tbody> <tr> <td>tanδ</td> <td>0.50</td> <td>0.40</td> <td>0.35</td> <td>0.25</td> <td>0.20</td> <td>0.15</td> <td>0.20</td> </tr> </tbody> </table>	WV	10	16	25, 35	50, 63	80, 100	160 ~ 400	450, 500	tanδ	0.50	0.40	0.35	0.25	0.20	0.15
WV	10	16	25, 35	50, 63	80, 100	160 ~ 400	450, 500									
tanδ	0.50	0.40	0.35	0.25	0.20	0.15	0.20									
Load life (after application of the rated voltage for 5000 hours at 105°C)	Leakage current	Less than specified value														
	Capacitance change	Within ± 25% of initial value														
	tanδ	Less than 250% of specified value														
Shelf life (at 105°C)	After 1000 hours no load test, leakage current, capacitance and tanδ are same as load life value. The measurement shall be performed at 20°C by the KS C IEC 60384 - 4															

## ● DRAWING

Unit : mm

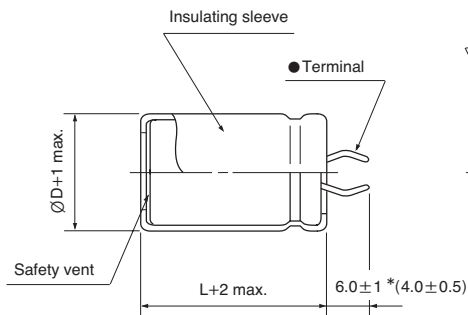

## ● Terminal

## PC Board Mounting Holes

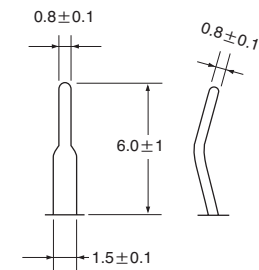

\* Shorter terminal(4.0±0.5) is also available upon request.  
 Terminal length of height 20mm products is applied shorter terminal to standard terminal type.

## ● FREQUENCY COEFFICIENT OF PERMISSIBLE RIPPLE CURRENT

WV	Frequency	50Hz	120Hz	300Hz	1kHz	10kHz ≤
~ 100		0.85	1.00	1.06	1.15	1.20
160 ~ 250		0.85	1.00	1.20	1.25	1.45
350 ~		0.85	1.00	1.15	1.20	1.40

# LARGE ALUMINUM ELECTROLYTIC CAPACITORS



**HL** series

● DIMENSIONS & MAXIMUM PERMISSIBLE RIPPLE CURRENT

WV μF / ØD	10				16				25			
	22	25.4	30	35	22	25.4	30	35	22	25.4	30	35
5600									22×25 1.50			
6800									22×30 1.90	25.4×25 1.90		
8200					22×25 1.80				22×35 2.10	25.4×30 2.10	30×25 2.10	
10000					22×30 2.20	25.4×25 2.20			22×40 2.30	25.4×35 2.30	30×25 2.20	
12000	22×30 2.10				22×35 2.40	25.4×30 2.40			22×40 2.50	25.4×35 2.50	30×30 2.60	
15000	22×30 2.30	25.4×25 2.30			22×40 2.70	25.4×35 2.70	30×30 2.70			25.4×40 2.80	30×35 2.90	35×30 2.90
18000	22×35 2.70	25.4×30 2.70			22×45 2.80	25.4×40 3.00	30×30 3.00	35×25 3.00		25.4×50 3.10	30×40 3.10	35×30 3.10
22000	22×40 2.90	25.4×35 2.90	30×30 2.90			25.4×40 3.10	30×35 3.30	35×30 3.30			30×45 3.50	35×35 3.50
27000	22×45 3.30	25.4×40 3.30	30×30 3.30	35×25 3.30			30×40 3.60	35×30 3.60			30×50 3.80	35×40 3.70
33000		25.4×45 3.50	30×35 3.50	35×30 3.50			30×45 4.00	35×35 4.00				35×45 4.10
39000			30×40 3.80	35×30 3.70			30×50 4.30	35×40 4.30				35×50 4.40
47000			30×45 4.00	35×35 3.90				35×45 4.60				
56000				35×40 4.50								

WV μF / ØD	35				50				63			
	22	25.4	30	35	22	25.4	30	35	22	25.4	30	35
1200									22×25 1.30			
1500									22×30 1.50	25.4×25 1.50		
1800					22×25 1.30				22×35 1.60	25.4×30 1.60	30×25 1.60	
2200					22×30 1.40				22×40 1.80	25.4×30 1.80	30×30 1.80	
2700					22×30 1.60	25.4×25 1.60			22×45 2.00	25.4×35 2.00	30×30 2.00	
3300	22×25 1.50				22×35 1.80	25.4×30 1.80			22×50 2.20	25.4×40 2.20	30×35 2.20	35×25 2.20
3900	22×30 1.60				22×40 1.90	25.4×30 1.90	30×25 1.90			25.4×45 2.40	30×35 2.40	35×30 2.40
4700	22×35 1.80	25.4×25 1.80			22×40 2.00	25.4×35 2.10	30×30 2.10	35×25 2.10		25.4×50 2.60	30×40 2.90	35×35 2.60
5600	22×35 2.00	25.4×30 2.00			22×45 2.20	25.4×40 2.30	30×35 2.30	35×25 2.30			30×45 2.80	35×35 2.80
6800	22×40 2.20	25.4×35 2.20	30×25 2.20		22×50 2.40	25.4×45 2.50	30×35 2.50	35×30 2.50				35×40 3.10
8200	22×45 2.30	25.4×35 2.30	30×30 2.40	35×25 2.40			30×40 2.80	35×30 2.70				35×45 3.40
10000		25.4×40 2.50	30×35 2.60	35×25 2.50			30×45 3.00	35×35 3.00				35×50 3.80
12000		25.4×45 2.80	30×35 2.80	35×30 2.90				35×40 3.30				
15000			30×40 3.10	35×35 3.20				35×45 3.70				
18000			30×45 3.30	35×40 3.50								
22000				35×45 3.70								

WV μF / ØD	80				100			
	22	25.4	30	35	22	25.4	30	35
680					22×25 1.10			
820	22×25 1.20				22×30 1.30	25.4×25 1.30		
1000	22×30 1.30	25.4×25 1.30			22×35 1.50	25.4×30 1.50		
1200	22×35 1.50	25.4×25 1.50			22×40 1.60	25.4×35 1.60	30×25 1.60	
1500	22×40 1.60	25.4×30 1.60	30×25 1.60		22×45 1.80	25.4×40 1.80	30×30 1.80	
1800	22×45 1.80	25.4×35 1.80	30×30 1.80			25.4×45 2.00	30×35 2.00	35×25 2.00
2200	22×50 2.00	25.4×40 2.00	30×30 2.00	35×25 2.00		25.4×50 2.20	30×40 2.20	35×30 2.20
2700		25.4×45 2.20	30×35 2.20	35×30 2.20			30×45 2.40	35×35 2.40
3300			30×40 2.40	35×35 2.40				35×40 2.70
3900			30×45 2.60	35×40 2.60				35×45 2.90
4700				35×45 3.00				
5600				35×50 3.30				

← Case size ØD×L (mm)  
 ← Ripple current (Arms) at 105°C, 120Hz

LARGE TYPES

# LARGE ALUMINUM ELECTROLYTIC CAPACITORS

**HL** series

## ● DIMENSIONS & MAXIMUM PERMISSIBLE RIPPLE CURRENT

WV μF ∅D	160				200				250			
	22	25.4	30	35	22	25.4	30	35	22	25.4	30	35
150					22×20 0.63				22×25 0.68	25.4×20 0.69		
180					22×20 0.69	25.4×20 0.76			22×25 0.74	25.4×20 0.76		
220	22×20 0.76				22×25 0.82	25.4×20 0.84			22×25 0.82	25.4×25 0.90	30×20 0.92	
270	22×25 0.91	25.4×20 0.93			22×25 0.91	25.4×25 1.00	30×20		22×30 0.97	25.4×25 1.00	30×20 1.02	
330	22×25 1.01	25.4×20 1.03			22×30 1.07	25.4×25 1.11	30×20 1.13		22×35 1.14	25.4×30 1.18	30×25 1.21	
390	22×25 1.09	25.4×25 1.20	30×20 1.23		22×30 1.17	25.4×25 1.20	30×25 1.31		22×40 1.30	25.4×35 1.35	30×25 1.31	35×25 1.42
470	22×30 1.28	25.4×25 1.32	30×20 1.35		22×35 1.36	25.4×30 1.40	30×25 1.44		22×45 1.50	25.4×35 1.48	30×30 1.53	35×25 1.56
560	22×35 1.48	25.4×30 1.53	30×25 1.57		22×40 1.56	25.4×30 1.53	30×25 1.57	35×25 1.70	22×50 1.71	25.4×40 1.70	30×30 1.67	35×25 1.70
680	22×40 1.72	25.4×30 1.69	30×25 1.73		22×45 1.80	25.4×35 1.79	30×30 1.84	35×25 1.88		25.4×50 2.05	30×35 1.94	35×30 1.98
820	22×45 1.98	25.4×35 1.96	30×30 2.02	35×25 2.06		25.4×45 2.16	30×30 2.02	35×25 2.06			30×40 2.23	35×35 2.29
1000	22×50 2.28	25.4×40 2.28	30×30 2.23	35×25 2.28		25.4×50 2.48	30×35 2.35	35×30 2.41			30×50 2.68	35×40 2.65
1200		25.4×45 2.41	30×35 2.38	35×30 2.44			30×40 2.50	35×35 2.57				35×45 2.80
1500		25.4×50 2.81	30×40 2.79	35×35 2.73			30×50 3.04	35×40 3.00				35×50 3.25

WV μF ∅D	350				400				450			
	22	25.4	30	35	22	25.4	30	35	22	25.4	30	35
68	22×20 0.41	25.4×20 0.45			22×20 0.58							
82	22×25 0.48	25.4×20 0.49			22×25 0.62	25.4×20 0.69			22×25 0.67	25.4×25 0.69		
100	22×25 0.53	25.4×25 0.58	30×20		22×25 0.74	25.4×20 0.75			22×25 0.79	25.4×25 0.81	30×20 0.84	
120	22×30 0.62	25.4×25 0.64	30×20		22×25 0.86	25.4×25 0.84	30×20 0.92		22×30 0.90	25.4×25 0.89	30×25 0.92	35×20 0.99
150	22×35 0.74	25.4×30 0.76	30×25		22×30 1.02	25.4×25 0.99	30×25 1.02		22×35 1.06	25.4×30 1.11	30×25 1.09	35×25 1.11
180	22×40 0.85	25.4×30 0.83	30×25		22×35 1.16	25.4×30 1.15	30×25 1.20		22×40 1.22	25.4×30 1.22	30×25 1.20	35×25 1.22
220	22×45 0.98	25.4×35 0.98	30×30	35×25 1.03	22×40 1.35	25.4×35 1.35	30×25 1.32	35×25 1.35	22×45 1.35	25.4×35 1.40	30×30 1.39	35×25 1.35
270	22×50 1.14	25.4×40 1.14	30×30	35×25 1.14	22×45 1.58	25.4×40 1.56	30×30 1.53	35×25 1.58		25.4×40 1.54	30×35 1.62	35×30 1.56
330		25.4×45 1.31	30×35	35×30 1.33		25.4×45 1.80	30×35 1.78	35×30 1.75			30×40 2.03	35×35 1.80
390		25.4×50 1.49	30×40	35×35 1.52			30×40 2.02	35×30 2.00			30×45 2.12	35×40 2.08
470			30×45	35×35 1.67			30×45 2.31	35×35 2.29			30×50 2.14	35×40 2.14
560			30×50	35×40 1.90			30×50 2.33	35×40 2.33				35×45 2.26
680								35×45 2.37				35×50 2.51

WV μF ∅D	500			
	22	25.4	30	35
68	22×30 0.81			
82	22×35 0.91	25.4×25 0.91		
100	22×40 1.04	25.4×30 1.04	30×25 1.01	
120	22×50 1.19	25.4×30 1.12	30×25 1.15	35×25 1.11
150	22×55 1.37	25.4×35 1.33	30×30 1.31	35×25 1.30
180	22×60 1.53	25.4×40 1.50	30×35 1.48	35×30 1.38
220		25.4×50 1.68	30×40 1.67	35×30 1.67
270			30×45 1.86	35×35 1.70
330			30×50 2.08	35×40 2.00
390				35×45 2.29
470				35×50 2.51

← Case size ∅D×L (mm)  
← Ripple current (Arms) at 105°C, 120Hz

# LARGE ALUMINUM ELECTROLYTIC CAPACITORS



New  
**JX**

Snap-in Terminal Type, High Voltage Series

- Load life of 5000 hours at 105°C
- Voltage range of 550, 600V
- Suited for use in industrial power supplies where high reliability
- Complied to the RoHS directive

HL  $\Rightarrow$  **JX**  
High Voltage



Item	Characteristics		
Operating temperature range	-25 ~ +105°C		
Capacitance tolerance	±20% at 120Hz, 20°C		
Leakage current max.	$I=3\sqrt{CV}$ (µA) (after 5 minutes)		
Dissipation factor max. (at 120Hz, 20°C)	WV	550	600
	tanδ	0.20	0.20
Load life (after application of the rated voltage for 5000 hours at 105°C)	Leakage current	Less than specified value	
	Capacitance change	Within ±20% of initial value	
	tanδ	Less than 300% of specified value	
Shelf life (at 105°C)	After 1000 hours no load test, leakage current, capacitance and tanδ are same as load life value. The measurement shall be performed at 20°C by the KS C IEC 60384 - 4		

## DRAWING

Unit : mm

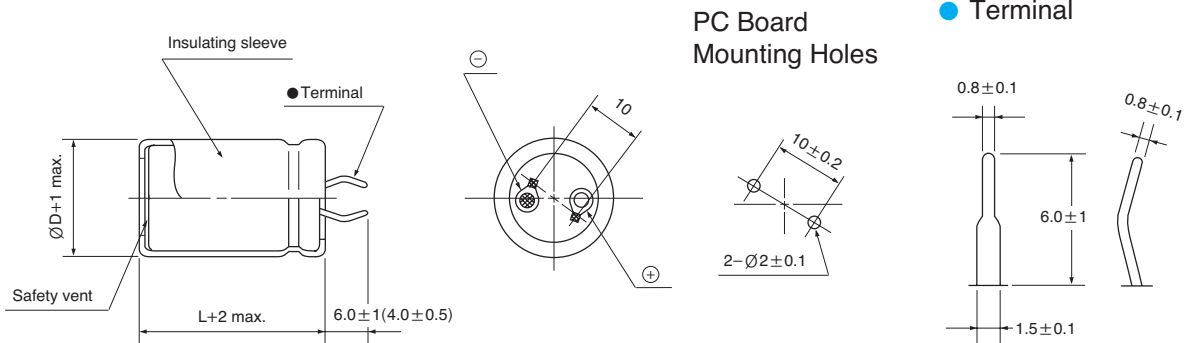

\* Shorter terminal(4.0±0.5) is also available upon request.  
Terminal length of height 20mm products is applied shorter terminal to standard terminal type.

## DIMENSIONS & MAXIMUM PERMISSIBLE RIPPLE CURRENT

WV µF	550				600			
	30		35		30		35	
120	30×30	1.04			30×40	1.01	35×30	1.00
150	30×35	1.14			30×45	1.16	35×35	1.12
180	30×40	1.31	35×30	1.26	30×50	1.28	35×40	1.28
220	30×50	1.50	35×40	1.47	30×60	1.47	35×45	1.45
270			35×45	1.67			35×50	1.64
330			35×50	1.82			35×60	1.88
390			35×60	2.04				

↑ ↑  
Ripple current (A rms) at 105°C, 120Hz  
Case size ∅D×L (mm)

## FREQUENCY COEFFICIENT OF PERMISSIBLE RIPPLE CURRENT

WV	Frequency	50Hz	120Hz	300Hz	1kHz	10kHz ≤
550, 600		0.85	1.00	1.15	1.20	1.40

LARGE TYPES

# LARGE ALUMINUM ELECTROLYTIC CAPACITORS

## HY Snap-in Terminal Type, Long Life Series

- Load life of 7000 hours at 105°C
- Voltage range of 160 ~ 500V
- Suited for use in industrial power supplies where high reliability
- Complied to the RoHS directive



Item	Characteristics															
Operating temperature range	WV<350: -40 ~ +105°C, WV ≥ 350: -25 ~ +105°C															
Capacitance tolerance	±20% at 120Hz, 20°C															
Leakage current max.	$I=3\sqrt{CV}$ (µA) (after 5 minutes)															
Dissipation factor max. (at 120Hz, 20°C)	Capacitance > 1000µF : tanδ increases by 0.01 for each 1000µF from below value.															
	<table border="1"> <thead> <tr> <th>WV</th> <th>160</th> <th>200</th> <th>250</th> <th>350</th> <th>400</th> <th>450</th> <th>500</th> </tr> </thead> <tbody> <tr> <td>tanδ</td> <td>0.15</td> <td>0.15</td> <td>0.15</td> <td>0.15</td> <td>0.15</td> <td>0.20</td> <td>0.20</td> </tr> </tbody> </table>	WV	160	200	250	350	400	450	500	tanδ	0.15	0.15	0.15	0.15	0.15	0.20
WV	160	200	250	350	400	450	500									
tanδ	0.15	0.15	0.15	0.15	0.15	0.20	0.20									
Load life (after application of the rated voltage for 7000 hours at 105°C)	Leakage current	Less than specified value														
	Capacitance change	Within ±30% of initial value														
	tanδ	Less than 300% of specified value														
Shelf life (at 105°C)	After 1000 hours no load test, leakage current, capacitance and tanδ are same as load life value. The measurement shall be performed at 20°C by the KS C IEC 60384 - 4															

### ● DRAWING

Unit : mm

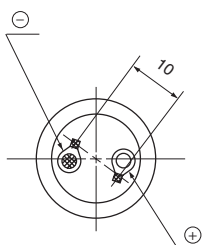
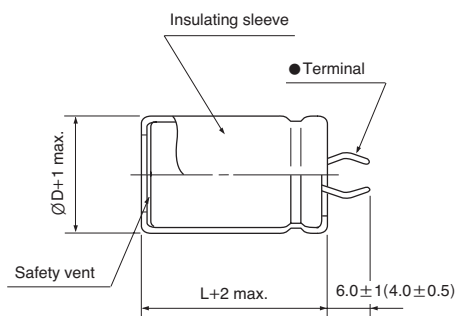

### PC Board Mounting Holes

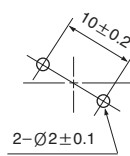

### ● Terminal

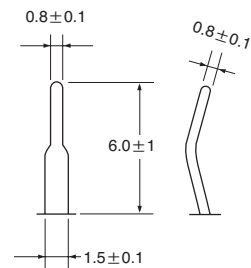

\* Shorter terminal(4.0±0.5) is also available upon request.  
Terminal length of height 20mm products is applied shorter terminal to standard terminal type.

### ● FREQUENCY COEFFICIENT OF PERMISSIBLE RIPPLE CURRENT

WV	Frequency	50Hz	120Hz	300Hz	1kHz	10kHz ≤
160 ~ 250		0.85	1.00	1.20	1.25	1.45
	350 ~	0.85	1.00	1.15	1.20	1.40

## ● DIMENSIONS & MAXIMUM PERMISSIBLE RIPPLE CURRENT

WV μF / ØD	160				200				250			
	22	25.4	30	35	22	25.4	30	35	22	25.4	30	35
330	22×25 1.11				22×30 1.16	25.4×25 1.16			22×40 1.19	25.4×35 1.24	30×25 1.20	
390	22×30 1.26	25.4×25 1.35			22×35 1.29	25.4×30 1.29	30×25 1.31		22×45 1.36	25.4×35 1.35	30×30 1.39	
470	22×30 1.39	25.4×30 1.40			22×40 1.42	25.4×35 1.48	30×30 1.52			25.4×45 1.63	30×35 1.61	35×30 1.64
560	22×40 1.55	25.4×30 1.55	30×25 1.57		22×45 1.63	25.4×35 1.62	30×30 1.67			25.4×50 1.85	30×35 1.75	35×30 1.80
680	22×45 1.80	25.4×35 1.78	30×30 1.93			25.4×40 1.87	30×35 1.93				30×45 2.12	35×35 2.08
820		25.4×40 2.06	30×30 2.01			25.4×50 2.24	30×40 2.23	35×30 2.17			30×50 2.42	35×40 2.39
1000		25.4×45 2.38	30×35 2.34				30×45 2.57	35×35 2.52				35×45 2.76
1200		25.4×50 2.54	30×40 2.56	35×35 2.56			30×50 2.71	35×40 2.68				35×50 2.90
1500			30×45 2.96	35×35 2.89				35×50 3.25				
1800			30×50 3.32	35×40 3.30								

WV μF / ØD	350				400				450			
	22	25.4	30	35	22	25.4	30	35	22	25.4	30	35
56					22×20 0.48				22×30 0.52	25.4×20 0.52		
68					22×25 0.55	25.4×20 0.55			22×30 0.58	25.4×25 0.58		
82	22×25 0.58				22×30 0.63	25.4×25 0.63			22×35 0.65	25.4×30 0.65	30×20 0.65	
100	22×25 0.67	25.4×25 0.67			22×30 0.70	25.4×25 0.70			22×40 0.74	25.4×30 0.72	30×25 0.73	
120	22×30 0.77	25.4×25 0.76			22×35 0.79	25.4×30 0.79	30×25 0.79			25.4×35 0.82	30×30 0.82	
150	22×35 0.88	25.4×30 0.88			22×40 0.90	25.4×30 0.88	30×25 0.90			25.4×40 0.94	30×35 0.96	35×25 0.94
180	22×40 0.99	25.4×30 0.96				25.4×35 1.01	30×30 1.01	35×25 1.01			30×35 1.05	35×30 1.07
220	22×45 1.12	25.4×35 1.11	30×30 1.11			25.4×40 1.14	30×35 1.16	35×25 1.14			30×40 1.20	35×35 1.21
270		25.4×40 1.26	30×35 1.28	35×25 1.26			30×40 1.33	35×30 1.31				35×40 1.40
330			30×35 1.42	35×30 1.45			30×45 1.52	35×35 1.48				35×45 1.60
390			30×40 1.60	35×35 1.61				35×40 1.68				35×50 1.79
470				35×40 1.85				35×45 1.91				
560				35×45 2.06				35×50 2.14				

WV μF / ØD	500			
	22	25.4	30	35
68	22×35 0.41	25.4×30 0.39		
82	22×40 0.47	25.4×30 0.46		
100	22×40 0.55	25.4×35 0.54	30×25 0.53	
120	22×45 0.61	25.4×40 0.62	30×30 0.61	35×25 0.56
150		25.4×45 0.69	30×35 0.72	35×30 0.70
180			30×40 0.84	35×35 0.83
220			30×45 0.97	35×40 0.97
270			30×50 1.17	35×40 1.18
330				35×50 1.32
390				35×55 1.48
470				35×60 1.60

← Case size ØD×L (mm)  
← Ripple current (Arms) at 105°C, 120Hz

# LARGE ALUMINUM ELECTROLYTIC CAPACITORS

## JY Snap-in Terminal Type, Long Life Series

- Load life of 10000 hours at 105°C
- Voltage range of 400 ~ 500V
- Suited for use in industrial power supplies where high reliability
- Complied to the RoHS directive



Item	Characteristics			
Operating temperature range	-25 ~ +105°C			
Capacitance tolerance	±20% at 120Hz, 20°C			
Leakage current max.	$I=3\sqrt{CV}$ (µA) (after 5 minutes)			
Dissipation factor max. (at 120Hz, 20°C)	WV	400	450	500
	tanδ	0.15	0.20	0.20
Load life (after application of the rated voltage for 10000 hours at 105°C)	Leakage current	Less than specified value		
	Capacitance change	Within ±30% of initial value		
	tanδ	Less than 300% of specified value		
Shelf life (at 105°C)	After 1000 hours no load test, leakage current, capacitance and tanδ are same as load life value. The measurement shall be performed at 20°C by the KS C IEC 60384 - 4			

● DRAWING (See page 183)

● DIMENSIONS & MAXIMUM PERMISSIBLE RIPPLE CURRENT

WV µF	ØD	400				450				500			
		22	25.4	30	35	22	25.4	30	35	22	25.4	30	35
47						22 × 20 0.38							
56	22 × 20 0.39					22 × 20 0.45	25.4 × 20 0.43						
68	22 × 25 0.46	25.4 × 20 0.48				22 × 25 0.52	25.4 × 25 0.51			22 × 35 0.41	25.4 × 30 0.39		
82	22 × 30 0.54	25.4 × 25 0.53				22 × 30 0.60	25.4 × 30 0.59	30 × 20 0.57		22 × 40 0.47	25.4 × 35 0.46		
100	22 × 30 0.60	25.4 × 25 0.62				22 × 30 0.69	25.4 × 30 0.69	30 × 25 0.67		22 × 40 0.55	25.4 × 40 0.52	30 × 30 0.56	
120	22 × 35 0.69	25.4 × 30 0.72	30 × 25 0.69				25.4 × 35 0.79	30 × 30 0.74		22 × 45 0.61	25.4 × 45 0.59	30 × 35 0.62	
150	22 × 40 0.84	25.4 × 30 0.84	30 × 25 0.82				25.4 × 40 0.92	30 × 35 0.91	35 × 25 0.89			30 × 40 0.65	35 × 30 0.66
180		25.4 × 35 0.97	30 × 30 0.95	35 × 25 0.92				30 × 35 1.04	35 × 30 1.03			30 × 45 0.72	35 × 35 0.73
220		25.4 × 40 1.11	30 × 35 1.11	35 × 25 1.08				30 × 40 1.20	35 × 35 1.19				35 × 40 0.84
270			30 × 40 1.28	35 × 30 1.26					35 × 40 1.37				35 × 50 0.92
330			30 × 45 1.47	35 × 35 1.46					35 × 45 1.58				
390				35 × 40 1.65									
470				35 × 45 1.88									

← Case size ØD×L (mm)  
← Ripple current (A rms) at 105°C, 120Hz

● FREQUENCY COEFFICIENT OF PERMISSIBLE RIPPLE CURRENT

WV	Frequency	50Hz	120Hz	300Hz	1kHz	10kHz ≤
400 ~ 500		0.85	1.00	1.15	1.20	1.40

## JZ Snap-in Terminal Type, Long Life Series

- Load life of 20000 hours at 105°C
- Voltage range of 400V, 500V
- Suited for use in industrial power supplies where high reliability
- Complied to the RoHS directive



Item	Characteristics															
Operating temperature range	-25 ~ +105°C															
Capacitance tolerance	±20% at 120Hz, 20°C															
Leakage current max.	$I=3\sqrt{CV}$ (µA) (after 5 minutes)															
Dissipation factor max. (at 120Hz, 20°C)	Capacitance > 1000µF : tanδ increases by 0.01 for each 1000µF from below value															
	<table border="1"> <tr> <td>WV</td> <td>10</td> <td>16</td> <td>25, 35</td> <td>50, 63</td> <td>80, 100</td> <td>160 ~ 400</td> <td>450</td> </tr> <tr> <td>tanδ</td> <td>0.50</td> <td>0.40</td> <td>0.35</td> <td>0.25</td> <td>0.20</td> <td>0.15</td> <td>0.20</td> </tr> </table>	WV	10	16	25, 35	50, 63	80, 100	160 ~ 400	450	tanδ	0.50	0.40	0.35	0.25	0.20	0.15
WV	10	16	25, 35	50, 63	80, 100	160 ~ 400	450									
tanδ	0.50	0.40	0.35	0.25	0.20	0.15	0.20									
Load life (after application of the rated voltage for 20000 hours at 105°C)	Leakage current	Less than specified value														
	Capacitance change	Within ±30% of initial value														
	tanδ	Less than 300% of specified value														
Shelf life (at 105°C)	After 1000 hours no load test, leakage current, capacitance and tanδ are same as load life value. The measurement shall be performed at 20°C by the KS C IEC 60384 - 4															

### DRAWING

Unit : mm

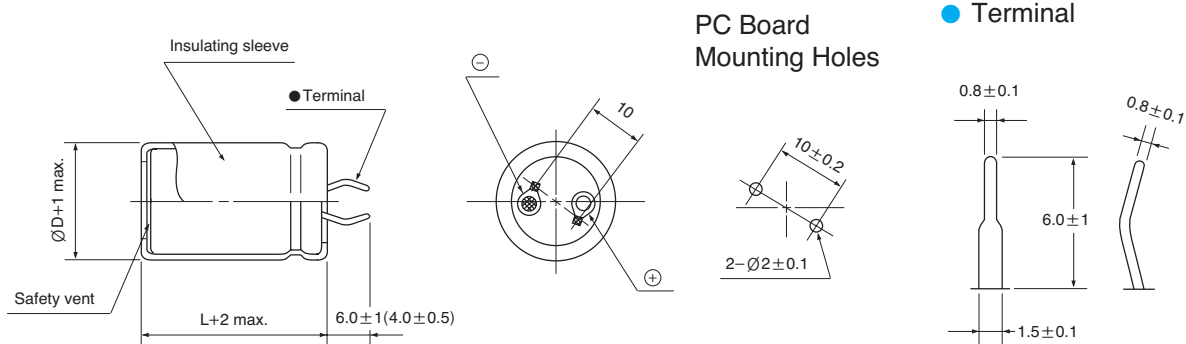

\* Shorter terminal(4.0 ± 0.5) is also available upon request.  
Terminal length of height 20mm products is applied shorter terminal to standard terminal type.

### FREQUENCY COEFFICIENT OF PERMISSIBLE RIPPLE CURRENT

WV	Frequency	50Hz	120Hz	300Hz	1kHz	10kHz ≤
~ 100	~ 100	0.85	1.00	1.06	1.15	1.20
	160 ~ 250	0.85	1.00	1.20	1.25	1.45
	350 ~	0.85	1.00	1.15	1.20	1.40



# LARGE ALUMINUM ELECTROLYTIC CAPACITORS

## ● DIMENSIONS & MAXIMUM PERMISSIBLE RIPPLE CURRENT

WV μF ∅D	10				16				25			
	22	25.4	30	35	22	25.4	30	35	22	25.4	30	35
2200									22×20 0.56			
2700					22×20 0.58				22×25 0.68	25.4×20 0.68		
3300	22×20 0.54				22×25 0.66	25.4×20 0.66			22×25 0.74	25.4×20 0.76		
3900	22×25 0.63	25.4×20 0.63			22×30 0.74	25.4×25 0.74	30×20 0.74		22×30 0.85	25.4×25 0.85	30×20 0.85	
4700	22×25 0.71	25.4×20 0.71			22×30 0.80	25.4×25 0.80	30×20 0.80		22×30 0.97	25.4×25 0.97	30×20 1.00	
5600	22×30 0.77	25.4×25 0.77	30×20 0.77		22×35 0.86	25.4×30 0.86	30×25 0.86	35×20 0.86	22×35 1.05	25.4×30 1.05	30×25 1.10	35×20 1.10
6800	22×30 0.91	25.4×25 0.91	30×25 0.91	35×20 0.91	22×35 1.06	25.4×30 1.06	30×25 1.06	35×20 1.06	22×40 1.20	25.4×35 1.20	30×30 1.30	35×25 1.30
8200	22×35 1.05	25.4×30 1.05	30×25 1.05	35×20 1.05	22×40 1.17	25.4×35 1.17	30×30 1.17	35×25 1.17	22×45 1.35	25.4×40 1.35	30×30 1.40	35×25 1.40
10000	22×40 1.33	25.4×35 1.33	30×30 1.33	35×25 1.33	22×45 1.40	25.4×40 1.40	30×35 1.40	35×25 1.40	22×50 1.60	25.4×45 1.60	30×35 1.60	35×30 1.60
12000	22×45 1.47	25.4×40 1.47	30×35 1.47	35×25 1.47	22×50 1.60	25.4×45 1.60	30×35 1.60	35×30 1.60		25.4×50 1.75	30×40 1.75	35×35 1.75
15000	22×50 1.60	25.4×45 1.60	30×35 1.60	35×30 1.60		25.4×50 1.80	30×40 1.80	35×35 1.80			30×45 1.95	35×40 1.95
18000		25.4×50 1.89	30×40 1.89	35×35 1.89			30×45 2.00	35×40 2.00			30×50 2.20	35×45 2.20
22000			30×45 2.03	35×40 2.03			30×50 2.20	35×45 2.20				35×50 2.45
27000			30×50 2.31	35×45 2.31				35×50 2.40				
33000				35×50 2.45								

WV μF ∅D	35				50				63			
	22	25.4	30	35	22	25.4	30	35	22	25.4	30	35
390									22×20 0.60			
470									22×25 0.68	25.4×20 0.68		
560					22×20 0.52				22×25 0.79	25.4×25 0.79	30×20 0.79	
680					22×25 0.58	25.4×20 0.58			22×30 0.85	25.4×25 0.85	30×20 0.85	
820					22×25 0.64	25.4×20 1.64			22×35 0.92	25.4×30 0.92	30×25 0.92	35×20 0.92
1000	22×20 0.55				22×30 0.70	25.4×25 0.70			22×40 1.00	25.4×30 1.00	30×25 1.10	35×20 1.10
1200	22×25 0.60	25.4×20 0.60			22×30 0.76	25.4×25 0.76	30×20 0.76		22×45 1.10	25.4×35 1.10	30×30 1.20	35×25 1.20
1500	22×25 0.68	25.4×25 0.68	30×20 0.68		22×35 0.82	25.4×30 0.82	30×25 0.82	35×20 0.82	22×50 1.33	25.4×40 1.33	30×30 1.33	35×25 1.33
1800	22×30 0.75	25.4×30 0.75	30×25 0.75	35×20 0.75	22×40 0.94	25.4×35 0.94	30×30 0.94	35×25 0.94		25.4×45 1.47	30×35 1.47	35×30 1.47
2200	22×35 0.82	25.4×30 0.82	30×25 0.86	35×20 0.86	22×45 1.07	25.4×40 1.07	30×35 1.07	35×25 1.07		25.4×50 1.61	30×40 1.61	35×35 1.61
2700	22×40 0.95	25.4×35 0.95	30×25 0.95	35×25 0.95	22×50 1.13	25.4×45 1.13	30×40 1.13	35×30 1.13			30×45 1.75	35×40 1.75
3300	22×45 1.10	25.4×40 1.10	30×30 1.10	35×25 1.10		25.4×50 1.43	30×45 1.43	35×35 1.43			30×50 2.00	35×45 2.00
3900	22×50 1.32	25.4×45 1.32	30×35 1.32	35×30 1.32			30×45 1.59	35×35 1.59				35×50 2.20
4700		25.4×45 1.50	30×40 1.50	35×30 1.60			30×50 1.82	35×40 1.82				
5600		25.4×50 1.80	30×45 1.80	35×35 1.80				35×45 2.00				
6800			30×50 2.05	35×40 2.10				35×50 2.25				
8200				35×45 2.33								
10000				35×50 2.50								

WV μF ∅D	80				100			
	22	25.4	30	35	22	25.4	30	35
220	22×20 0.58				22×20 0.62			
270	22×25 0.65	25.4×20 0.65			22×25 0.70	25.4×20 0.70		
330	22×30 0.72	25.4×25 0.72	30×20 0.72		22×30 0.79	25.4×25 0.79	30×20 0.79	
390	22×30 0.80	25.4×25 0.80	30×20 0.80		22×35 0.85	25.4×25 0.85	30×20 0.85	
470	22×35 0.88	25.4×30 0.88	30×25 0.88	35×20 0.88	22×35 0.95	25.4×30 0.95	30×25 0.95	35×20 0.95
560	22×40 1.00	25.4×30 1.00	30×30 1.00	35×20 1.00	22×40 1.10	25.4×35 1.10	30×25 1.10	35×25 1.10
680	22×45 1.12	25.4×35 1.12	30×30 1.12	35×25 1.12	22×45 1.21	25.4×40 1.21	30×30 1.21	35×25 1.21
820	22×50 1.20	25.4×40 1.20	30×35 1.20	35×30 1.20	22×50 1.40	25.4×45 1.40	30×35 1.40	35×30 1.40
1000		25.4×45 1.40	30×40 1.40	35×35 1.40		25.4×50 1.68	30×40 1.68	35×30 1.68
1200		25.4×50 1.62	30×40 1.62	35×35 1.62			30×45 1.90	35×35 1.90
1500			30×45 1.85	35×40 1.85			30×50 2.10	35×40 2.10
1800			30×50 2.14	35×45 2.14				35×45 2.33
2200				35×50 2.26				35×50 2.50

← Case size ∅D×L (mm)  
← Ripple current (Arms) at 105°C, 120Hz

## JZ series

### ● DIMENSIONS & MAXIMUM PERMISSIBLE RIPPLE CURRENT

WV μF / ØD	160				200				250			
	22	25.4	30	35	22	25.4	30	35	22	25.4	30	35
82					22×20 0.52				22×20 0.50			
100					22×25 0.55				22×25 0.53	25.4×20 0.58		
120					22×25 0.58	25.4×20 0.60			22×25 0.60	25.4×25 0.64		
150	22×20 0.58				22×30 0.63	25.4×25 0.65	30×20 0.68		22×30 0.68	25.4×25 0.69	30×20 0.71	
180	22×25 0.65	25.4×20 0.70			22×35 0.69	25.4×30 0.76	30×25 0.78	35×20 0.80	22×35 0.74	25.4×30 0.76	30×25 0.78	35×20 0.80
220	22×25 0.76	25.4×25 0.80	30×20 0.86		22×40 0.78	25.4×30 0.81	30×25 0.85	35×20 0.88	22×40 0.82	25.4×35 0.90	30×25 0.92	35×25 0.95
270	22×30 0.91	25.4×25 0.93	30×20 0.98		22×45 0.91	25.4×35 1.00	30×30 1.02	35×25 1.04	22×45 0.97	25.4×40 1.00	30×30 1.02	35×25 1.10
330	22×35 1.01	25.4×30 1.03	30×25 1.06	35×20 1.08	22×50 1.07	25.4×40 1.11	30×35 1.13	35×25 1.17	22×50 1.14	25.4×45 1.18	30×35 1.21	35×30 1.28
390	22×40 1.09	25.4×30 1.20	30×25 1.23	35×25 1.26		25.4×45 1.20	30×40 1.31	35×30 1.38		25.4×50 1.30	30×40 1.31	35×30 1.44
470	22×45 1.28	25.4×35 1.32	30×30 1.35	35×25 1.40		25.4×50 1.40	30×45 1.44	35×35 1.52			30×45 1.53	35×35 1.60
560	22×50 1.48	25.4×40 1.53	30×35 1.57	35×25 1.60			30×50 1.57	35×40 1.70			30×50 1.67	35×40 1.70
680		25.4×45 1.69	30×40 1.73	35×30 1.82				35×45 1.88				35×45 1.98
820		25.4×50 1.96	30×45 2.02	35×35 2.10				35×50 2.06				35×50 2.29
1000			30×50 2.23	35×40 2.28								
1200				35×45 2.44								
1500				35×50 2.73								

WV μF / ØD	350				400				450			
	22	25.4	30	35	22	25.4	30	35	22	25.4	30	35
33									22×20 0.40			
47					22×20 0.40				22×25 0.42	25.4×20 0.44		
56	22×20 0.36				22×25 0.42	25.4×20 0.44			22×25 0.45	25.4×25 0.47		
68	22×25 0.41				22×30 0.45	25.4×25 0.47			22×30 0.49	25.4×30 0.52	30×20 0.54	
82	22×25 0.48	25.4×20 0.50			22×30 0.49	25.4×25 0.49	30×20 0.52		22×35 0.56	25.4×30 0.56	30×25 0.59	35×20 0.62
100	22×30 0.53	25.4×25 0.58			22×35 0.56	25.4×30 0.56	30×25 0.65	35×20 0.66	22×40 0.64	25.4×35 0.64	30×30 0.67	35×25 0.67
120	22×35 0.62	25.4×30 0.64	30×20 0.68		22×40 0.68	25.4×35 0.68	30×30 0.72	35×25 0.72	22×45 0.72	25.4×40 0.72	30×35 0.76	35×25 0.76
150	22×40 0.74	25.4×35 0.76	30×25 0.80	35×20 0.82	22×45 0.75	25.4×40 0.75	30×35 0.79	35×25 0.79		25.4×45 0.79	30×40 0.83	35×30 0.83
180	22×45 0.85	25.4×35 0.86	30×30 0.90	35×25 0.95		25.4×45 0.79	30×40 0.88	35×30 0.88			30×45 0.92	35×35 0.92
220	22×50 0.98	25.4×40 1.00	30×30 1.06	35×25 1.10			30×45 1.00	35×35 1.00				35×40 1.05
270		25.4×45 1.14	30×35 1.20	35×30 1.28				35×40 1.19				35×45 1.25
330		25.4×50 1.31	30×40 1.38	35×35 1.42				35×45 1.38				35×50 1.45
390			30×45 1.48	35×40 1.52								
470				35×45 1.67								

← Case size ØD×L (mm)  
 ← Ripple current (Arms) at 105°C, 120Hz

# LARGE ALUMINUM ELECTROLYTIC CAPACITORS

## HB High Temperature Range, For 125°C Use Series

- Wide operating temperature range of -40 ~ +125°C
- With a guaranteed useful life of 10 years at 60°C
- Ideal for industrial applications requiring continuous operation
- Complied to the RoHS directive

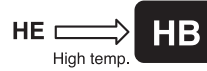

Item	Characteristics																	
Operating temperature range	WV < 350 : -40 ~ +125°C, WV ≥ 350 : -25 ~ +125°C																	
Capacitance tolerance	± 20% at 120Hz, 20°C																	
Leakage current max.	$I = 3 \sqrt{CV}$ (µA) (after 5 minutes)																	
Dissipation factor max. (at 120Hz, 20°C)	Capacitance > 1000µF : tanδ increases by 0.01 for each 1000µF from below value.																	
	<table border="1"> <thead> <tr> <th>WV</th> <th>10</th> <th>16</th> <th>25</th> <th>35</th> <th>50, 63</th> <th>80 ~ 160</th> <th>200 ~ 400</th> <th>450</th> </tr> </thead> <tbody> <tr> <td>tanδ</td> <td>0.50</td> <td>0.40</td> <td>0.30</td> <td>0.25</td> <td>0.20</td> <td>0.17</td> <td>0.15</td> <td>0.20</td> </tr> </tbody> </table>	WV	10	16	25	35	50, 63	80 ~ 160	200 ~ 400	450	tanδ	0.50	0.40	0.30	0.25	0.20	0.17	0.15
WV	10	16	25	35	50, 63	80 ~ 160	200 ~ 400	450										
tanδ	0.50	0.40	0.30	0.25	0.20	0.17	0.15	0.20										
Load life (after application of the rated voltage for 1000 hours at 125°C)	Leakage current	Less than specified value																
	Capacitance change	Within ± 20% of initial value																
	tanδ	Less than 200% of specified value																
Shelf life (at 125°C)	400WV, 450WV products are for 3000 hours After 1000 hours no load test, leakage current, capacitance and tanδ are same as load life value. The measurement shall be performed at 20°C by the KS C IEC 60384 - 4																	

### ● DRAWING

Unit : mm

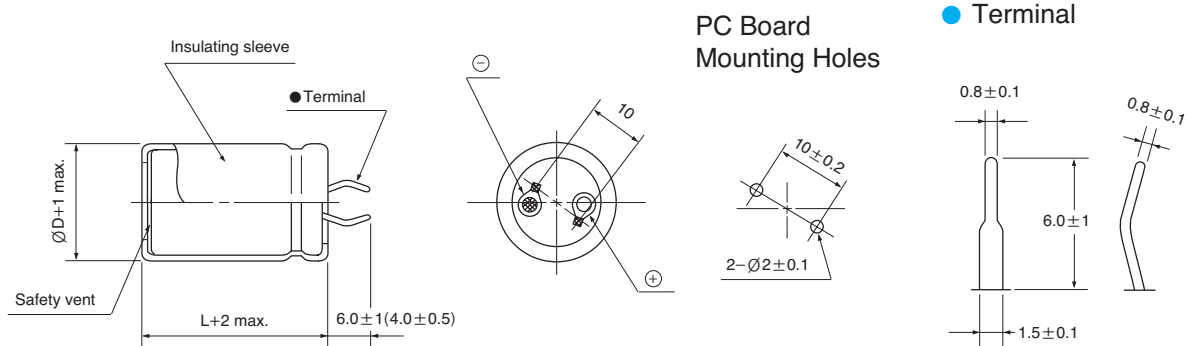

\* Shorter terminal(4.0 ± 0.5) is also available upon request.  
Terminal length of height 20mm products is applied shorter terminal to standard terminal type.

### ● FREQUENCY COEFFICIENT OF PERMISSIBLE RIPPLE CURRENT

WV	Frequency	50Hz	120Hz	300Hz	1kHz	10kHz ≤
~ 100	~ 100	0.85	1.00	1.06	1.15	1.20
	160 ~ 250	0.85	1.00	1.20	1.25	1.45
400 ~		0.85	1.00	1.15	1.20	1.40

## HB series

### ● DIMENSIONS & MAXIMUM PERMISSIBLE RIPPLE CURRENT

WV μF / ØD	10				16				25			
	22	25.4	30	35	22	25.4	30	35	22	25.4	30	35
1500									22×30 0.95			
2200					22×30 1.00				22×40 1.28	25.4×30 1.26		
3300	22×30 1.09				22×40 1.36	25.4×35 1.41			22×50 1.72	25.4×40 1.72	30×30 1.68	
4700	22×40 1.45	25.4×35 1.51			22×50 1.78	25.4×40 1.77	30×30 1.74			25.4×50 2.23	30×40 2.22	35×30 2.17
6800	22×50 1.91	25.4×40 1.91	30×35 1.97				30×40 2.31	35×30 2.26			30×50 2.90	35×40 2.87
10000			30×45 2.62	35×35 2.57				35×45 3.14				
15000				35×45 3.44								

WV μF / ØD	35				50				63			
	22	25.4	30	35	22	25.4	30	35	22	25.4	30	35
470									22×35 0.69	25.4×30 0.71		
680					22×30 0.78				22×40 0.87	25.4×35 0.91	30×30 0.93	
1000	22×30 0.85				22×40 1.06	25.4×30 1.04				25.4×45 1.21	30×35 1.19	35×30 1.22
1500	22×40 1.16	25.4×30 1.14			22×50 1.42	25.4×40 1.42	30×30 1.39				30×45 1.60	35×40 1.65
2200	22×50 1.54	25.4×40 1.54	30×30 1.50				30×40 1.86	35×35 1.91				35×50 2.16
3300			30×40 2.04	35×35 2.09				35×40 2.45				
4700				35×40 2.61								

WV μF / ØD	80				100				160			
	22	25.4	30	35	22	25.4	30	35	22	25.4	30	35
150									22×30 0.37			
220					22×30 0.48				22×40 0.50	25.4×30 0.49		
330	22×30 0.59				22×40 0.66	25.4×30 0.65			22×50 0.67	25.4×40 0.67	30×30 0.65	
470	22×40 0.79	25.4×35 0.82			22×50 0.86	25.4×40 0.86	30×35 0.89			25.4×50 0.87	30×40 0.86	35×30 0.84
680		25.4×40 1.04	30×35 1.07				30×40 1.12	35×30 1.09			30×50 1.12	35×40 1.11
1000			30×45 1.42	35×35 1.40				35×40 1.46				35×50 1.46
1500				35×45 1.86								

WV μF / ØD	200				250				400		450		
	22	25.4	30	35	22	25.4	30	35	30	35	30	35	
100					22×30 0.32								
150	22×35 0.42				22×40 0.44	25.4×30 0.43							
220	22×45 0.56	25.4×40 0.58	30×30 0.57		22×50 0.58	25.4×40 0.58	30×35 0.60	35×30 0.61					
270											30×40 1.31	35×30 1.34	
330		25.4×50 0.77	30×40 0.77	35×30 0.75			30×45 0.80	35×35 0.79	30×35 1.41	35×30 1.48	30×45 1.48	35×35 1.51	
390									30×45 1.61	35×35 1.64	30×50 1.64	35×40 1.70	
470			30×50 0.99	35×40 0.98				35×45 1.03	30×50 1.80	35×40 1.86	30×60 1.87	35×45 1.91	
560									30×55 2.01	35×45 2.08		35×55 2.17	
680				35×50 1.28	← Case size ØD×L (mm) ← Ripple current (A rms) at 125°C, 120Hz						35×50 2.34		35×60 2.43
820										35×60 2.67			

# LARGE ALUMINUM ELECTROLYTIC CAPACITORS

## LM Lug Terminal Type Series

- Lug terminal series
- Suited for use in power supplies and industrial controls
- Complied to the RoHS directive



Item	Characteristics											
Operating temperature range	WV < 350 : -40 ~ +85°C, WV ≥ 350 : -25 ~ +85°C											
Capacitance tolerance	± 20% at 120Hz, 20°C											
Leakage current max.	$I = 3 \sqrt{CV}$ (µA) (after 5 minutes)											
Dissipation factor max. (at 120Hz, 20°C)	Capacitance > 1000µF : tanδ increases by 0.01 for each 1000µF from below value.											
	<table border="1"> <thead> <tr> <th>WV</th> <th>16</th> <th>25</th> <th>35~63</th> <th>80~350</th> <th>400~450</th> </tr> </thead> <tbody> <tr> <td>tanδ</td> <td>0.35</td> <td>0.30</td> <td>0.25</td> <td>0.20</td> <td>0.25</td> </tr> </tbody> </table>	WV	16	25	35~63	80~350	400~450	tanδ	0.35	0.30	0.25	0.20
WV	16	25	35~63	80~350	400~450							
tanδ	0.35	0.30	0.25	0.20	0.25							
Load life (after application of the rated voltage for 2000 hours at 85°C)	Leakage current	Less than specified value										
	Capacitance change	Within ± 20% of initial value										
	tanδ	Less than 200% of specified value										
Shelf life (at 85°C)	After 1000 hours no load test, leakage current, capacitance and tanδ are same as load life value. The measurement shall be performed at 20°C by the KS C IEC 60384 - 4											

### ● DRAWING

Unit : mm

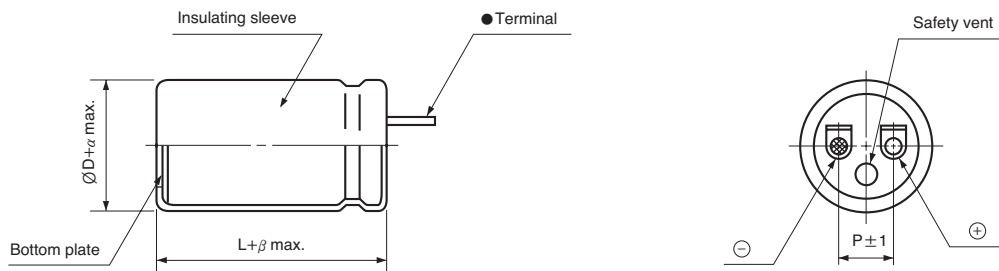

### ● TERMINAL

For solder tag

∅D	≤ 35	40	51
Dimensions			
Code	LC	LA	LD

∅D	25.4	30	35	40	51
P	10	10	14	18	18
α	1				2
β	2				3

### ● FREQUENCY COEFFICIENT OF PERMISSIBLE RIPPLE CURRENT

WV	Frequency	50Hz	120Hz	300Hz	1kHz	10kHz ≤
~ 100		0.85	1.00	1.06	1.15	1.20
160 ~ 250		0.85	1.00	1.20	1.25	1.45
315 ~		0.85	1.00	1.15	1.20	1.40

## LM series

### ● DIMENSIONS & MAXIMUM PERMISSIBLE RIPPLE CURRENT

μF \ WV	16		25		35		40		50	
	4700									25.4×30
6800					25.4×30	3.67	25.4×30	3.85	25.4×35	4.07
10000			25.4×30	3.89	25.4×35	4.53	25.4×40	4.87	30×40	5.08
15000	25.4×30	4.41	25.4×40	4.94	30×40	5.72	30×40	6.24	35×40	6.67
22000	25.4×40	5.44	30×40	6.02	35×40	6.95	35×40	7.44	35×50	7.85
33000	30×40	6.56	35×40	7.15	35×50	8.16	35×60	8.93	40×60	9.62
47000	35×40	7.54	35×50	8.15	40×60	9.45	51×60	10.8	51×70	11.0
68000	35×50	8.63	40×60	9.32	51×70	10.8				
100000	40×60	10.2	51×70	11.7						
150000	51×70	12.5								

μF \ WV	63		80		100		160		200	
	470									25.4×30
680							25.4×35	1.60	25.4×40	1.60
1000							25.4×40	2.09	30×35	2.09
1500					25.4×30	2.13	30×45	2.69	35×40	2.87
2200			25.4×30	2.52	25.4×40	2.75	35×45	3.40	35×50	3.81
3300	25.4×30	2.73	25.4×40	3.29	30×40	3.55	35×60	5.02	40×60	5.27
4700	25.4×35	3.50	25.4×60	4.14	35×40	4.76	40×80	6.15	51×70	6.80
6800	25.4×45	4.38	30×60	5.15	35×60	6.17	51×80	7.86		
10000	30×45	5.46	35×60	7.08	40×80	8.16				
15000	35×50	7.25	40×80	8.43	51×80	10.2				
22000	35×60	8.58	51×80	11.3						
33000	51×70	10.4								

μF \ WV	250		315		350		400		450	
	150									25.4×30
220			25.4×30	0.84	25.4×30	0.91	25.4×35	0.81	30×30	0.88
330	25.4×30	1.02	25.4×35	1.12	25.4×40	1.20	30×35	1.16	30×35	1.24
470	25.4×35	1.33	25.4×45	1.43	30×40	1.54	35×35	1.47	35×40	1.65
680	30×35	1.73	30×50	1.86	35×45	1.98	35×45	1.99	35×50	2.18
1000	30×45	2.25	35×50	2.56	35×60	2.96	40×60	2.78	35×70	2.77
1500	35×50	3.22	35×70	3.54	40×60	3.72	51×60	3.69		
2200	35×70	4.19	40×100	4.40	51×80	4.86				
3300	51×70	5.24	51×90	5.82						

Ripple current (A rms) at 85°C, 120Hz  
 Case size ØD×L (mm)

# LARGE ALUMINUM ELECTROLYTIC CAPACITORS

## GT Screw Terminal Type, Standard Series

- Ideally suited for use as input and output filter capacitors in power supplies
- Suited for smoothing circuits for general purpose inverters and control circuits for F.A. machines
- Designed for use as input filter capacitor for current U.P.S.
- Complied to the RoHS directive



Item	Characteristics																																																												
Operating temperature range	WV < 350 : -40 ~ +85°C, WV ≥ 350 : -25 ~ +85°C																																																												
Capacitance tolerance	±20% at 120Hz, 20°C																																																												
Leakage current max.	$I = 3 \sqrt{CV}$ (μA) (after 5 minutes)																																																												
Dissipation factor max. (at 120Hz, 20°C)	<table border="1"> <thead> <tr> <th>∅D \ WV</th> <th>16</th> <th>25</th> <th>35</th> <th>50</th> <th>63</th> <th>80</th> <th>100</th> <th>160 ~ 250</th> <th>350 ~ 500</th> </tr> </thead> <tbody> <tr> <td>35</td> <td>0.70</td> <td>0.45</td> <td>0.45</td> <td>0.30</td> <td>0.25</td> <td>0.25</td> <td>0.20</td> <td>0.15</td> <td>0.25</td> </tr> <tr> <td>51</td> <td>1.00</td> <td>0.60</td> <td>0.60</td> <td>0.45</td> <td>0.35</td> <td>0.30</td> <td>0.20</td> <td>0.15</td> <td>0.25</td> </tr> <tr> <td>63.5</td> <td>1.30</td> <td>0.80</td> <td>0.70</td> <td>0.50</td> <td>0.40</td> <td>0.35</td> <td>0.25</td> <td>0.20</td> <td>0.25</td> </tr> <tr> <td>76.2</td> <td>2.00</td> <td>1.60</td> <td>0.90</td> <td>0.70</td> <td>0.50</td> <td>0.45</td> <td>0.35</td> <td>0.25</td> <td>0.25</td> </tr> <tr> <td>89</td> <td>2.50</td> <td>2.40</td> <td>1.00</td> <td>0.80</td> <td>0.60</td> <td>0.50</td> <td>0.40</td> <td>0.30</td> <td>0.25</td> </tr> </tbody> </table>	∅D \ WV	16	25	35	50	63	80	100	160 ~ 250	350 ~ 500	35	0.70	0.45	0.45	0.30	0.25	0.25	0.20	0.15	0.25	51	1.00	0.60	0.60	0.45	0.35	0.30	0.20	0.15	0.25	63.5	1.30	0.80	0.70	0.50	0.40	0.35	0.25	0.20	0.25	76.2	2.00	1.60	0.90	0.70	0.50	0.45	0.35	0.25	0.25	89	2.50	2.40	1.00	0.80	0.60	0.50	0.40	0.30	0.25
	∅D \ WV	16	25	35	50	63	80	100	160 ~ 250	350 ~ 500																																																			
	35	0.70	0.45	0.45	0.30	0.25	0.25	0.20	0.15	0.25																																																			
	51	1.00	0.60	0.60	0.45	0.35	0.30	0.20	0.15	0.25																																																			
	63.5	1.30	0.80	0.70	0.50	0.40	0.35	0.25	0.20	0.25																																																			
76.2	2.00	1.60	0.90	0.70	0.50	0.45	0.35	0.25	0.25																																																				
89	2.50	2.40	1.00	0.80	0.60	0.50	0.40	0.30	0.25																																																				
Load life (after application of the rated voltage for 2000 hours at 85°C)	Leakage current	Less than specified value																																																											
	Capacitance change	WV ≤ 250 : Within ±15% of the initial value WV ≥ 350 : Within ±20% of the initial value																																																											
	tanδ	WV ≤ 250 : Less than 175% of the specified value WV ≥ 350 : Less than 300% of the specified value																																																											
Shelf life (at 85°C)	After 1000 hours no load test, leakage current, capacitance and tanδ are same as load life value. The measurement shall be performed at 20°C by the KS C IEC 60384 - 4																																																												

### ● DRAWING

Unit : mm

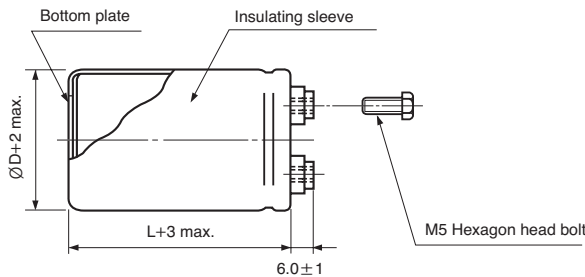

### ● TWO LEGS ANGLE

### ● THREE LEGS ANGLE

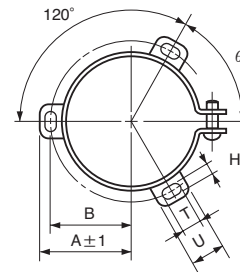
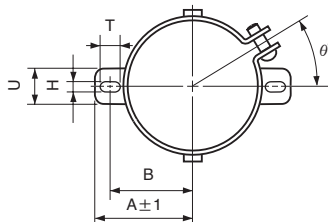

### ● TWO LEGS ANGLE SIZE TABLE

∅D	B	A	T	U	θ°	P	H
35	24	29	7	10	30	12.7	3.5
51	33.6	39.9	6	14	30	22	4.4
63.5	38.5	45.0	8	16	45	28.6	5.0

### ● THREE LEGS ANGLE SIZE TABLE

∅D	B	A	T	U	θ°	P	H
51	32.9	38.9	7	12	60	22.0	4.5
63.5	38.4	45.3	7	14	60	28.6	4.5
76.2	44.5	51.5	8	16	60	31.8	4.5
89	50.8	61	8	16	60	31.8	5.0

## GT series

### ● DIMENSIONS & MAXIMUM PERMISSIBLE RIPPLE CURRENT

μF \ WV	16		25		35		50	
	10000							35×60
15000					35×50	5.8	35×80	8.5
22000			35×60	7.5	35×70	7.9	35×100	11.3
33000	35×60	7.4	35×80	10.3	35×100	11.3	35×120	15.0
47000	35×80	9.9	35×100	13.5	35×120	14.6	51×100	15.2
68000	35×100	13.1	51×80	14.5	51×100	15.9	51×120	19.7
100000	51×80	13.7	51×100	19.2	51×120	20.7	63.5×120	24.2
150000	51×100	18.3	51×140	27.1	63.5×120	25.1	76.2×120	25.9
220000	51×140	25.4	63.5×120	28.4	76.2×120	27.7	76.2×160	35.1
330000	63.5×120	27.3	76.2×120	29.3				
470000	76.2×120	29.5						

μF \ WV	63		80		100		160	
	1500							35×60
2200							35×80	4.6
3300							35×100	6.2
4700					35×60	5.2	51×80	7.7
6800	35×50	5.2	35×60	5.6	35×80	7.0	51×100	10.0
10000	35×60	6.8	35×80	7.6	35×100	9.4	51×140	14.1
15000	35×80	9.3	35×120	11.1	51×80	11.8	63.5×140	16.5
22000	35×120	13.4	51×80	11.7	51×100	15.6	76.2×140	17.6
33000	51×100	14.5	51×120	16.8	51×140	22.0		
47000	51×120	18.6	63.5×100	18.5	63.5×140	25.0		
68000	63.5×100	20.8	63.5×140	25.4	76.2×140	26.2		
100000	76.2×120	25.0	76.2×140	29.7				
150000	76.2×140	32.5						

μF \ WV	200		250	
	330			
470				
680			35×50	2.1
1000	35×60	2.8	35×70	2.9
1500	35×70	3.6	35×80	3.8
2200	35×100	5.1	35×120	5.5
3300	35×120	6.7	51×100	7.0
4700	51×100	8.3	51×140	9.6
6800	51×140	11.5	63.5×120	10.0
10000	63.5×120	12.1	76.2×120	11.2
15000	76.2×120	13.7	76.2×160	15.3
22000	76.2×160	18.6		

← Ripple current (A rms) at 85°C, 120Hz  
 ← Case size ØD×L (mm)



# LARGE ALUMINUM ELECTROLYTIC CAPACITORS

**GT** series

● DIMENSIONS & MAXIMUM PERMISSIBLE RIPPLE CURRENT

WV Item μF	350			400			450		
	∅D×L (mm)	Ripple current (A rms)		∅D×L (mm)	Ripple current (A rms)		∅D×L (mm)	Ripple current (A rms)	
		40°C 120Hz	85°C 120Hz		40°C 120Hz	85°C 120Hz		40°C 120Hz	85°C 120Hz
180							35×60	2.9	1.0
220				35×50	3.0	1.1	35×60	3.2	1.1
270	35×50	3.3	1.2	35×50	3.3	1.2	35×60	3.6	1.7
330	35×50	3.7	1.3	35×50	3.9	1.8	35×80	4.4	2.0
390	35×60	4.3	2.1	35×60	4.3	2.0	35×80	4.8	2.2
470	35×60	4.7	2.3	35×80	5.3	2.6	35×80	5.8	2.6
560	35×80	5.8	2.5	35×80	6.3	2.9	35×100	6.3	3.0
680	35×80	6.4	3.1	35×100	7.0	3.3	35×100	7.5	3.3
820	35×100	7.7	3.5	35×100	8.3	3.7	35×120	8.0	4.6
1000	35×100	9.2	4.1	35×120	8.8	4.8	51×80	9.6	5.0
1200	35×120	9.7	5.2	51×80	9.7	5.2	51×100	10.6	6.1
1500	51×80	10.8	5.9	51×100	11.8	5.9	51×100	12.7	6.7
1800	51×100	12.9	6.2	51×100	13.9	6.9	51×110	13.8	7.9
2200	51×100	15.4	7.8	51×120	16.4	8.5	51×120	16.3	8.5
2700	51×140	18.2	8.3	63.5×100	18.1	9.5	51×140	19.2	9.8
3300	51×130	20.4	10.9	51×140	22.8	10.6	51×140	20.3	11.6
	63.5×100	20.0	10.9	63.5×120	21.3	11.3	63.5×120	20.6	11.2
3900	63.5×120	23.1	12.8	63.5×130	24.4	13.1	63.5×130	23.7	11.9
				76.2×100	24.4	13.0	76.2×100	23.5	12.8
4700	63.5×130	26.8	14.3	63.5×160	26.9	13.2	63.5×160	27.8	14.0
	76.2×100	27.8	13.9	76.2×120	26.0	14.1	76.2×120	27.5	15.0
5600	76.2×120	28.4	15.0	76.2×130	30.0	16.2	76.2×130	31.3	16.8
6800	76.2×130	33.0	17.2	76.2×140	34.5	18.5	76.2×140	33.8	18.1
	89×120	32.5	17.0	89×120	34.5	19.1	89×130	33.5	18.9
8200	76.2×160	38.4	20.5	76.2×160	39.8	20.1	76.2×160	42.8	19.4
	89×140	37.8	20.3	89×130	39.8	20.9	89×140	42.8	19.7
10000	89×160	44.0	22.8	89×140	44.0	21.8	89×160	49.8	20.6
12000	89×160	47.3	24.3	89×160	47.6	22.8	89×190	58.5	21.9
15000	89×190	56.6	25.6	89×190	57.4	23.3			

WV Item μF	500		
	∅D×L (mm)	Ripple current (A rms)	
		40°C 120Hz	85°C 120Hz
1000	51×120	12.2	4.2
1200	63.5×100	13.1	4.5
1500	63.5×100	14.8	5.1
1800	63.5×120	17.4	6.0
2200	63.5×140	20.3	7.0
2700	76.2×120	22.3	7.9
3300	76.2×140	26.1	8.8
3900	76.2×160	27.2	10.4
4700	89×140	31.1	11.1
6800	89×160	37.8	13.5
8200	89×190	44.5	15.9

● FREQUENCY COEFFICIENT OF PERMISSIBLE RIPPLE CURRENT

WV	Frequency	50Hz	120Hz	300Hz	1kHz	10kHz <sub>≤</sub>
	~ 100	0.8	1.0	1.1	1.15	1.2
	160 ~ 250	0.8	1.0	1.1	1.15	1.3
	350 ~	0.8	1.0	1.2	1.35	1.4

## GY Screw Terminal Type, High Ripple Series

- Screw terminal series in compact sizes
- High ripple guaranteed for 2000 hours load life at 85°C
- Suited for smoothing circuits for general purpose inverters and control circuits for F.A. machines
- Designed for use as input filter capacitor for current U.P.S.
- Complied to the RoHS directive

GT ⇒ **GY**  
High Ripple



Item	Characteristics	
Operating temperature range	-25 ~ +85°C	
Capacitance tolerance	±20% at 120Hz, 20°C	
Leakage current max.	$I=3\sqrt{CV}$ (µA) (after 5 minutes)	
Dissipation factor max.	0.25 max. at 120Hz, 20°C	
Load life (after application of the rated voltage for 2000 hours at 85°C)	Leakage current	Less than specified value
	Capacitance change	Within ±20% of initial value
	tanδ	Less than 300% of specified value
Shelf life (at 85°C)	After 1000 hours no load test, leakage current, capacitance and tanδ are same as load life value. The measurement shall be performed at 20°C by the KS C IEC 60384 - 4	

● DRAWING (See page 216)

● DIMENSIONS & MAXIMUM PERMISSIBLE RIPPLE CURRENT

WV Item µF	450	
	∅D×L (mm)	Ripple current (A rms) 85°C 120Hz
2700	63.5 × 90	11.6
3300	63.5 × 105	13.3
3900	63.5 × 115	15.1
	76.2 × 95	15.7
4700	63.5 × 135	17.8
	76.2 × 105	17.7
5600	76.2 × 115	20.0
6800	76.2 × 135	23.2
8200	89 × 125	24.8
10000	89 × 150	29.7

● FREQUENCY COEFFICIENT OF PERMISSIBLE RIPPLE CURRENT

WV Frequency	50Hz	120Hz	300Hz	1kHz	3kHz
450	0.8	1.0	1.1	1.3	1.4

# LARGE ALUMINUM ELECTROLYTIC CAPACITORS

## CU Screw Terminal Type, Wide Temperature Range Series

- Screw terminal series for high temperature up to 105°C
- High ripple current capability
- Ideally suited for use as input and output filter capacitors in power supplies
- Complied to the RoHS directive

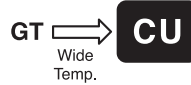

Item	Characteristics																																																																		
Operating temperature range	WV < 350 : -40 ~ +105°C, WV ≥ 350 : -25 ~ +105°C																																																																		
Capacitance tolerance	±20% at 120Hz, 20°C																																																																		
Leakage current max.	$I = 3 \sqrt{CV}$ (µA) (after 5 minutes)																																																																		
Dissipation factor max. (at 120Hz, 20°C)	<table border="1"> <thead> <tr> <th>∅D \ WV</th> <th>16</th> <th>25</th> <th>35</th> <th>50</th> <th>63</th> <th>80</th> <th>100</th> <th>160</th> <th>200, 250</th> <th>350~500</th> </tr> </thead> <tbody> <tr> <td>35</td> <td>0.50</td> <td>0.45</td> <td>0.40</td> <td>0.30</td> <td>0.25</td> <td>0.25</td> <td>0.20</td> <td>0.15</td> <td>0.15</td> <td>0.25</td> </tr> <tr> <td>51</td> <td>0.70</td> <td>0.60</td> <td>0.45</td> <td>0.45</td> <td>0.35</td> <td>0.30</td> <td>0.20</td> <td>0.15</td> <td>0.15</td> <td>0.25</td> </tr> <tr> <td>63.5</td> <td>1.00</td> <td>0.80</td> <td>0.60</td> <td>0.50</td> <td>0.40</td> <td>0.35</td> <td>0.25</td> <td>0.20</td> <td>0.20</td> <td>0.25</td> </tr> <tr> <td>76.2</td> <td>1.60</td> <td>1.20</td> <td>0.80</td> <td>0.65</td> <td>0.60</td> <td>0.45</td> <td>0.35</td> <td>0.30</td> <td>0.20</td> <td>0.25</td> </tr> <tr> <td>89</td> <td>2.50</td> <td>1.50</td> <td>1.00</td> <td>0.80</td> <td>0.70</td> <td>0.50</td> <td>0.40</td> <td>0.35</td> <td>0.25</td> <td>0.25</td> </tr> </tbody> </table>	∅D \ WV	16	25	35	50	63	80	100	160	200, 250	350~500	35	0.50	0.45	0.40	0.30	0.25	0.25	0.20	0.15	0.15	0.25	51	0.70	0.60	0.45	0.45	0.35	0.30	0.20	0.15	0.15	0.25	63.5	1.00	0.80	0.60	0.50	0.40	0.35	0.25	0.20	0.20	0.25	76.2	1.60	1.20	0.80	0.65	0.60	0.45	0.35	0.30	0.20	0.25	89	2.50	1.50	1.00	0.80	0.70	0.50	0.40	0.35	0.25	0.25
	∅D \ WV	16	25	35	50	63	80	100	160	200, 250	350~500																																																								
	35	0.50	0.45	0.40	0.30	0.25	0.25	0.20	0.15	0.15	0.25																																																								
	51	0.70	0.60	0.45	0.45	0.35	0.30	0.20	0.15	0.15	0.25																																																								
	63.5	1.00	0.80	0.60	0.50	0.40	0.35	0.25	0.20	0.20	0.25																																																								
	76.2	1.60	1.20	0.80	0.65	0.60	0.45	0.35	0.30	0.20	0.25																																																								
89	2.50	1.50	1.00	0.80	0.70	0.50	0.40	0.35	0.25	0.25																																																									
Load life (after application of the rated voltage for 2000 hours at 105°C)	Leakage current	Less than specified value																																																																	
	Capacitance change	Within ±20% of initial value																																																																	
	tanδ	Less than 300% of specified value																																																																	
Shelf life (at 105°C)	After 1000 hours no load test, leakage current, capacitance and tanδ are same as load life value. The measurement shall be performed at 20°C by the KS C IEC 60384 - 4																																																																		

### ● DRAWING

Unit : mm

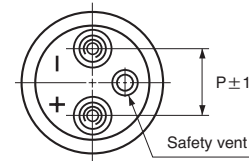
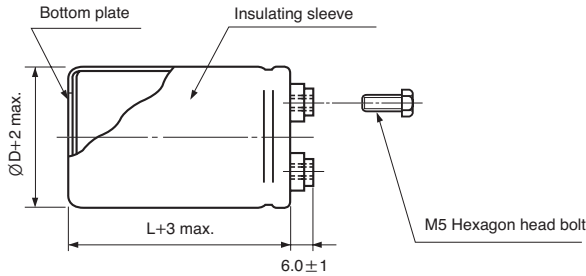

### ● TWO LEGS ANGLE

### ● THREE LEGS ANGLE

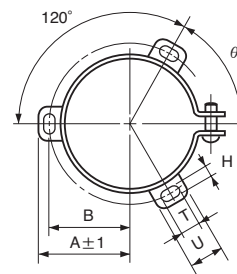
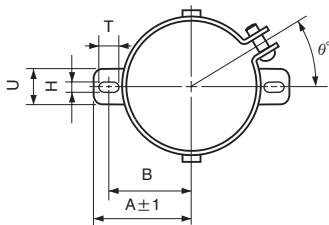

### ● TWO LEGS ANGLE SIZE TABLE

∅D	B	A	T	U	θ°	P	H
35	24	29	7	10	30	12.7	3.5
51	33.6	39.9	6	14	30	22	4.4
63.5	38.5	45.0	8	16	45	28.6	5.0

### ● THREE LEGS ANGLE SIZE TABLE

∅D	B	A	T	U	θ°	P	H
51	32.9	38.9	7	12	60	22.0	4.5
63.5	38.4	45.3	7	14	60	28.6	4.5
76.2	44.5	51.5	8	16	60	31.8	4.5
89	50.8	61	8	16	60	31.8	5.0

## CU series

### ● DIMENSIONS & MAXIMUM PERMISSIBLE RIPPLE CURRENT

$\mu\text{F}$ \diagdown WV	16		25		35		50	
6800							35×50	3.1
10000					35×60	3.5	35×60	4.0
15000			35×50	3.8	35×80	4.8	35×80	5.5
22000	35×60	4.9	35×68	5.1	35×100	6.4	35×120	8.0
33000	35×80	6.7	35×100	7.4	35×120	8.5	51×100	8.3
47000	35×100	8.8	35×120	9.5	51×100	9.9	51×120	10.7
68000	51×80	9.5	51×100	10.3	51×120	12.8	63.5×100	12.6
100000	51×100	12.5	51×120	13.5	63.5×120	16.4	76.2×120	13.7
150000	51×140	17.6	63.5×120	16.9	76.2×120	17.4	76.2×140	17.9
220000	63.5×120	18.4	76.2×120	18.0	76.2×160	22.8		
330000	76.2×120	19.1						
470000	76.2×160	25.5						

$\mu\text{F}$ \diagdown WV	63		80		100		160	
1000							35×60	1.7
1500					35×60	1.9	35×68	2.1
2200					35×80	2.6	35×100	3.0
3300					35×100	3.5	35×120	4.0
4700			35×60	3.0	51×80	4.3	51×100	5.0
6800	35×60	3.7	35×80	4.1	51×100	5.7	51×140	7.0
10000	35×80	5.0	35×100	5.4	51×140	7.9	63.5×120	7.3
15000	35×120	7.2	51×80	6.3	63.5×140	9.2	76.2×120	7.0
22000	51×80	7.0	51×100	8.3	76.2×140	11.0	76.2×160	9.4
33000	51×120	10.1	51×140	11.7				
47000	63.5×100	11.7	63.5×140	14.3				
68000	63.5×140	16.0	76.2×140	15.8				
100000	76.2×140	18.2						

↑ ↑  
 Ripple current (A rms) at 105°C, 120Hz  
 Case size ØD×L (mm)

# LARGE ALUMINUM ELECTROLYTIC CAPACITORS

**CU** series

## ● DIMENSIONS & MAXIMUM PERMISSIBLE RIPPLE CURRENT

$\mu\text{F}$ \diagdown WV	200		250		350		400	
1000	35×60	1.8	35×80	2.1	35×100	3.4	51×70	3.2
1500	35×80	2.3	35×100	2.6	51×80	4.4	51×80	4.8
2200	35×120	3.3	51×80	3.4	51×100	5.7	51×120	6.4
3300	51×100	4.2	51×120	4.8	51×130	8.0	51×140	10.5
					63.5×100	7.8	63.5×120	10.5
4700	51×140	5.8	63.5×100	5.2	63.5×120	9.0	63.5×140	12.8
					76.2×100	8.8	76.2×120	12.5
6800	63.5×120	6.2	63.5×120	5.5	63.5×140	12.6	76.2×140	15.1
					76.2×120	12.4	89×120	15.4
10000	76.2×120	6.7	76.2×140	7.5	76.2×160	15.0	76.2×190	19.8
					89×140	15.3	89×160	20.1
12000	76.2×140	7.8	76.2×160	8.0	89×140	17.1	89×190	23.0
15000	76.2×160	9.2	89×140	9.4	89×190	21.5		

$\mu\text{F}$ \diagdown WV	450		500	
2200	63.5×100	6.7	63.5×130	7.0
2700	63.5×120	7.9	63.5×150	8.6
3300	63.5×140	9.4	76.2×130	9.7
	76.2×100	8.7		
3900	63.5×150	10.8	76.2×150	10.7
	76.2×120	10.5		
4700	76.2×130	11.9	76.2×160	12.0
	89×120	11.9		
5600	76.2×140	13.3	89×140	13.8
	89×130	13.5		
6800	76.2×160	14.9	89×160	15.5
	89×140	14.9		
8200	76.2×190	17.7	89×190	18.0
	89×160	17.6		
10000	89×190	21.0		
12000	89×190	23.1		

Ripple current (A rms) at 105°C, 120Hz  
Case size  $\varnothing D \times L$  (mm)

## ● FREQUENCY COEFFICIENT OF PERMISSIBLE RIPPLE CURRENT

WV \ Frequency	50Hz	120Hz	300Hz	1kHz	10kHz $\leq$
~ 100	0.8	1.0	1.1	1.15	1.2
160 ~ 250	0.8	1.0	1.1	1.15	1.3
350 ~	0.8	1.0	1.2	1.35	1.4

## GF For Inverter Circuits Series

- Screw terminal series in compact case size
- High reliability, long life guaranteed for 5000 hours load life at 85°C
- Suited for use in industrial power supplies for inverters
- Complied to the RoHS directive



Item	Characteristics	
Operating temperature range	-25 ~ +85°C	
Capacitance tolerance	±20% at 120Hz, 20°C	
Leakage current max.	$I=3 \sqrt{CV}$ (µA) (after 5 minutes)	
Dissipation factor max.	0.25 max. at 120Hz, 20°C	
Load life (after application of the rated voltage for 5000 hours at 85°C)	Leakage current	Less than specified value
	Capacitance change	Within ±30% of initial value
	tanδ	Less than 300% of specified value
Shelf life (at 85°C)	After 1000 hours no load test, leakage current, capacitance and tanδ are same as load life value. The measurement shall be performed at 20°C by the KS C IEC 60384 - 4	

### DRAWING

Unit : mm

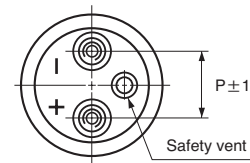
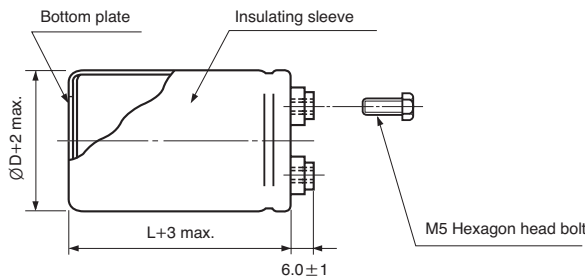

### TWO LEGS ANGLE

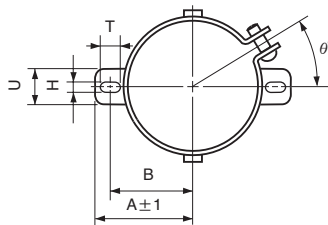

### THREE LEGS ANGLE

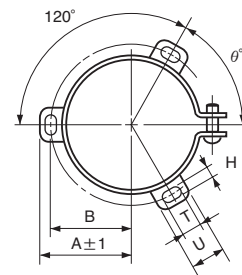

### TWO LEGS ANGLE SIZE TABLE

ØD	B	A	T	U	θ°	P	H
35	24	29	7	10	30	12.7	3.5
51	33.6	39.9	6	14	30	22	4.4
63.5	38.5	45.0	8	16	45	28.6	5.0

### THREE LEGS ANGLE SIZE TABLE

ØD	B	A	T	U	θ°	P	H
51	32.9	38.9	7	12	60	22.0	4.5
63.5	38.4	45.3	7	14	60	28.6	4.5
76.2	44.5	51.5	8	16	60	31.8	4.5
89	50.8	61	8	16	60	31.8	5.0

# LARGE ALUMINUM ELECTROLYTIC CAPACITORS

**GF** series

## ● DIMENSIONS & MAXIMUM PERMISSIBLE RIPPLE CURRENT

WV Item $\mu$ F	350			400			450		
	$\varnothing D \times L$ (mm)	Ripple current (A rms)		$\varnothing D \times L$ (mm)	Ripple current (A rms)		$\varnothing D \times L$ (mm)	Ripple current (A rms)	
		40°C 120Hz	85°C 120Hz		40°C 120Hz	85°C 120Hz		40°C 120Hz	85°C 120Hz
2200	51 × 80	9.6	6.0	51 × 100	13.4	8.4	51 × 120	13.8	8.6
2700	51 × 100	11.4	7.1	51 × 110	16.0	10.0	63.5 × 100	16.8	10.5
3300	51 × 110	12.0	7.5	63.5 × 100	18.6	11.6	63.5 × 110	19.0	11.9
3900	63.5 × 100	13.1	8.2	63.5 × 100	19.7	12.3	76.2 × 100	22.2	13.9
4700	63.5 × 100	15.2	9.5	63.5 × 120	23.2	14.5	76.2 × 110	24.8	15.5
5600	63.5 × 120	16.8	10.5	76.2 × 110	26.4	16.5	76.2 × 130	25.4	15.9
6800	76.2 × 110	19.7	12.3	76.2 × 120	28.0	17.5	76.2 × 150	29.4	18.4
8200	76.2 × 120	23.5	14.7	76.2 × 140	29.9	18.7	89 × 140	31.5	19.7
10000	76.2 × 140	27.7	17.3	89 × 140	32.8	20.5			
12000	89 × 140	31.2	19.5	89 × 150	33.6	21.0			

WV Item $\mu$ F	500			550			600		
	$\varnothing D \times L$ (mm)	Ripple current (A rms)		$\varnothing D \times L$ (mm)	Ripple current (A rms)		$\varnothing D \times L$ (mm)	Ripple current (A rms)	
		40°C 120Hz	85°C 120Hz		40°C 120Hz	85°C 120Hz		40°C 120Hz	85°C 120Hz
1000				51 × 100	6.7	4.2	51 × 100	9.8	6.5
1200				51 × 110	8.0	5.0	63.5 × 90	11.1	7.4
1500				51 × 130	9.6	6.0	63.5 × 100	13.2	8.8
1800	63.5 × 100	10.4	6.5	63.5 × 100	10.7	6.7	76.2 × 90	15.0	10.0
2200	63.5 × 120	12.3	7.7	63.5 × 120	12.8	8.0	76.2 × 100	17.9	11.9
2700	76.2 × 100	14.1	8.8	76.2 × 100	15.0	9.4	76.2 × 120	20.9	13.9
3300	76.2 × 120	16.6	10.4	76.2 × 130	17.6	11.0	76.2 × 140	24.6	16.4
3900	76.2 × 130	19.4	12.1	76.2 × 140	20.0	12.5	89 × 120	23.4	15.6
4700							89 × 140	27.5	18.3
5600							89 × 160	31.5	21.0

## ● FREQUENCY COEFFICIENT OF PERMISSIBLE RIPPLE CURRENT

WV	Frequency	50Hz	120Hz	300Hz	1kHz	3kHz
350 ~ 600		0.8	1.0	1.1	1.3	1.4

## GR For Inverter Circuits Series

- Screw terminal series in compact case sizes
- High ripple, long life guaranteed for 5000 hours load life at 85°C
- Suited for use in industrial power supplies for inverters
- Complied to the RoHS directive

GF  $\Rightarrow$  GR  
High Ripple



Item	Characteristics	
Operating temperature range	-25 ~ +85°C	
Capacitance tolerance	±20% at 120Hz, 20°C	
Leakage current max.	$I=3\sqrt{CV}$ (µA) (after 5 minutes)	
Dissipation factor max. (at 120Hz, 20°C)	0.25 max. at 120Hz, 20°C	
Load life (after application of the rated voltage for 5000 hours at 85°C)	Leakage current	Less than specified value
	Capacitance change	Within ±30% of the initial value
	tanδ	Less than 300% of specified value
Shelf life (at 85°C)	After 1000 hours no load test, leakage current, capacitance and tanδ are same as load life value. The measurement shall be performed at 20°C by the KS C IEC 60384 - 4	

### DRAWING

Unit : mm

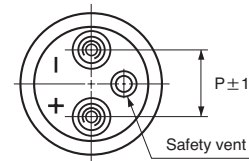
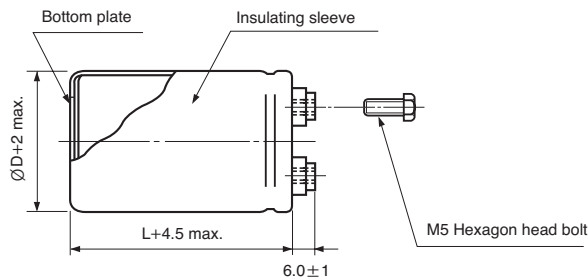

#### TWO LEGS ANGLE

#### THREE LEGS ANGLE

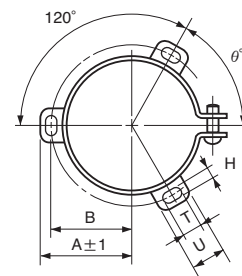
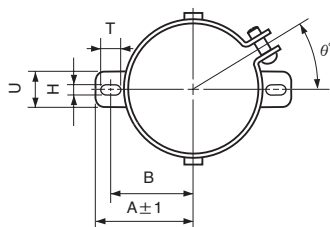

#### TWO LEGS ANGLE SIZE TABLE

ØD	B	A	T	U	θ°	P	H
35	24	29	7	10	30	12.7	3.5
51	33.6	39.9	6	14	30	22	4.4
63.5	38.5	45.0	8	16	45	28.6	5.0

#### THREE LEGS ANGLE SIZE TABLE

ØD	B	A	T	U	θ°	P	H
51	32.9	38.9	7	12	60	22.0	4.5
63.5	38.4	45.3	7	14	60	28.6	4.5
76.2	44.5	51.5	8	16	60	31.8	4.5
89	50.8	61	8	16	60	31.8	5.0



# LARGE ALUMINUM ELECTROLYTIC CAPACITORS

**GR** series

● DIMENSIONS & MAXIMUM PERMISSIBLE RIPPLE CURRENT

WV Item μF	400			450		
	∅D×L (mm)	Ripple current (A rms)		∅D×L (mm)	Ripple current (A rms)	
		40°C 120Hz	85°C 120Hz		40°C 120Hz	85°C 120Hz
1000	51 × 60	14.0	9.3	51 × 70	15.0	10.0
1200	51 × 65	15.0	10.0	51 × 80	16.1	10.7
1500	51 × 80	17.6	11.7	51 × 90	16.8	11.2
1800	51 × 85	19.5	13.0	51 × 105	18.6	12.4
				63.5 × 70	19.4	12.9
2200	51 × 100	21.0	14.0			
	63.5 × 70	20.7	13.8	63.5 × 85	20.0	13.3
				76.2 × 65	20.3	13.5
2700	63.5 × 80	23.6	15.7	63.5 × 90	22.2	14.8
	76.2 × 65	23.1	15.4	76.2 × 75	22.2	14.8
3300	63.5 × 90	24.2	16.1	63.5 × 110	25.2	16.8
	76.2 × 70	24.8	16.5	76.2 × 85	25.1	16.7
3900	63.5 × 100	26.7	17.8	63.5 × 135	28.1	18.7
	76.2 × 80	27.8	18.5	76.2 × 90	27.6	18.4
4700	63.5 × 120	30.5	20.3	63.5 × 145	31.1	20.7
	76.2 × 90	29.7	19.8	76.2 × 110	31.1	20.7
5600	63.5 × 135	33.9	22.6	63.5 × 165	34.7	23.1
	76.2 × 100	32.7	21.8	76.2 × 130	35.0	23.3
				89 × 95	37.7	25.1
6800	63.5 × 165	38.6	25.7			
	76.2 × 120	37.4	24.9	76.2 × 145	38.6	25.7
	89 × 90	42.6	28.4	89 × 115	44.6	29.7
8200	76.2 × 140	42.3	28.2	76.2 × 185	44.1	29.4
	89 × 105	47.9	31.9	89 × 135	49.4	32.9
10000	76.2 × 165	47.9	31.9			
	89 × 120	53.9	35.9	89 × 155	55.2	36.8

● FREQUENCY COEFFICIENT OF PERMISSIBLE RIPPLE CURRENT

WV	Frequency	50Hz	120Hz	300Hz	1kHz	3kHz
400, 450		0.8	1.0	1.1	1.3	1.4

# LARGE ALUMINUM ELECTROLYTIC CAPACITORS



## GL Screw Terminal Type, Long Life Series



- Screw terminal series in compact case sizes
- High reliability, long life guaranteed for 20000 hours load life at 85°C
- Suited for use in industrial power supplies for inverters
- Complied to the RoHS directive



Item	Characteristics	
Operating temperature range	-25 ~ +85°C	
Capacitance tolerance	±20% at 120Hz, 20°C	
Leakage current max.	$I=3\sqrt{CV}$ (µA) (after 5 minutes)	
Dissipation factor max.	0.25 max. at 120Hz, 20°C	
Load life (after application of the rated voltage for 20000 hours at 85°C)	Leakage current	Less than specified value
	Capacitance change	Within ±30% of initial value
	tanδ	Less than 300% of specified value
Shelf life (at 85°C)	After 1000 hours no load test, leakage current, capacitance and tanδ are same as load life value. The measurement shall be performed at 20°C by the KS C IEC 60384 - 4	

### ● DRAWING (See page 216)

### ● DIMENSIONS & MAXIMUM PERMISSIBLE RIPPLE CURRENT

WV Item µF	350		400		450	
	ØD×L (mm)	Ripple current (A rms) 85°C 120Hz	ØD×L (mm)	Ripple current (A rms) 85°C 120Hz	ØD×L (mm)	Ripple current (A rms) 85°C 120Hz
1500					51 × 110	7.3
1800			51 × 110	8.2	51 × 130	8.7
2200	51 × 110	8.8	51 × 130	9.3	63.5 × 110	9.6
2700	51 × 130	10.3	63.5 × 110	10.8	63.5 × 130	11.3
3300	63.5 × 100	11.8	63.5 × 130	12.9	76.2 × 110	13.5
3900	63.5 × 110	13.0	76.2 × 100	15.0	76.2 × 130	15.3
4700	76.2 × 100	15.2	76.2 × 130	16.0	76.2 × 150	16.9
5600	76.2 × 110	18.3	76.2 × 150	18.3	76.2 × 160	21.8
6800	76.2 × 130	20.5	76.2 × 160	21.2	89 × 150	23.6
8200	76.2 × 150	23.5	89 × 150	24.6	89 × 160	26.5
10000	89 × 150	27.1	89 × 160	29.3		
12000	89 × 160	32.2				

### ● FREQUENCY COEFFICIENT OF PERMISSIBLE RIPPLE CURRENT

WV Frequency	50Hz	120Hz	300Hz	1kHz	3kHz
350 ~ 450	0.8	1.0	1.1	1.3	1.4

# LARGE ALUMINUM ELECTROLYTIC CAPACITORS

**EV** High ripple Current, High Reliability Series



- High ripple current compared with CU series
- Long life guaranteed for 5000 hours load life at 105°C
- Suited for the general-purpose inverter
- Complied to the RoHS directive



Item	Characteristics	
Operating temperature range	-25 ~ +105°C	
Capacitance tolerance	±20% at 120Hz, 20°C	
Leakage current max.	$I = 3\sqrt{CV}$ (μA) (after 5 minutes)	
Dissipation factor max.	0.20 max. at 120Hz, 20°C	
Load life (after application of the rated voltage for 5000 hours at 105°C)	Leakage current	Less than specified value
	Capacitance change	Within ±20% of initial value
	tanδ	Less than 200% of specified value
	500WV products are for 2000hours	
Shelf life (at 105°C)	After 1000 hours no load test, leakage current, capacitance and tanδ are same as load life value. The measurement shall be performed at 20°C by the KS C IEC 60384 - 4	

● DRAWING (See page 216)

● DIMENSIONS & MAXIMUM PERMISSIBLE RIPPLE CURRENT

WV Item μF	400		450		500	
	ØD×L (mm)	Ripple Current (A rms) 105°C 120Hz	ØD×L (mm)	Ripple Current (A rms) 105°C 120Hz	ØD×L (mm)	Ripple Current (A rms) 105°C 120Hz
1000					51 × 130	6.3
1500					63.5 × 110	8.1
2200	63.5 × 110	11.6	63.5 × 115	12.1	76.2 × 130	10.1
2700	63.5 × 115	13.7	63.5 × 130	14.3	76.2 × 140	12.6
3300	63.5 × 130	16.1	76.2 × 130	16.9	76.2 × 150	14.3
3900	63.5 × 140	18.1	76.2 × 140	20.5	89 × 160	15.0
4700	76.2 × 130	21.2	76.2 × 150	22.6	89 × 160	16.5
5600	76.2 × 150	24.3	76.2 × 160	26.8		
6800	89 × 150	27.1	89 × 150	28.2		

● FREQUENCY COEFFICIENT OF PERMISSIBLE RIPPLE CURRENT

WV Frequency	50Hz	120Hz	300Hz	1kHz	3kHz
400 ~ 500	0.8	1.0	1.1	1.3	1.4

## EY High Reliability Long Life Series



- High reliability, long life guaranteed for 7000 hours load life at 105°C
- Suited for use in industrial power supplies for inverter
- Complied to the RoHS directive



Item	Characteristics	
Operating temperature range	-25 ~ +105°C	
Capacitance tolerance	±20% at 120Hz, 20°C	
Leakage current max.	$I=3\sqrt{CV}$ (μA) (after 5 minutes)	
Dissipation factor max.	0.20 max. at 120Hz, 20°C	
Load life (after application of the rated voltage for 7000 hours at 105°C)	Leakage current	Less than specified value
	Capacitance change	Within ±20% of initial value
	tanδ	Less than 300% of specified value
Shelf life (at 105°C)	After 1000 hours no load test, leakage current, capacitance and tanδ are same as load life value. The measurement shall be performed at 20°C by the KS C IEC 60384 - 4	

● DRAWING (See page 216)

● DIMENSIONS & MAXIMUM PERMISSIBLE RIPPLE CURRENT

WV Item μF	350		400		450	
	∅D×L (mm)	Ripple current (A rms) 105°C 120Hz	∅D×L (mm)	Ripple current (A rms) 105°C 120Hz	∅D×L (mm)	Ripple current (A rms) 105°C 120Hz
1500					51 × 110	6.1
1800			51 × 110	7.4	51 × 130	7.1
2200	51 × 110	8.2	51 × 130	8.8	63.5 × 110	7.8
2700	51 × 130	9.8	63.5 × 110	9.7	63.5 × 130	9.2
3300	63.5 × 100	10.3	63.5 × 130	11.4	76.2 × 110	9.9
3900	63.5 × 110	11.6	76.2 × 100	11.6	76.2 × 130	11.4
4700	76.2 × 100	12.7	76.2 × 130	14.0	76.2 × 150	13.2
5600	76.2 × 110	14.3	76.2 × 150	16.2	76.2 × 160	14.8
6800	76.2 × 130	16.8	76.2 × 160	18.3	89 × 150	17.5
8200	76.2 × 150	20.1	89 × 150	21.5	89 × 160	19.7
10000	89 × 150	23.7	89 × 160	24.3		
12000	89 × 160	26.7				

● FREQUENCY COEFFICIENT OF PERMISSIBLE RIPPLE CURRENT

WV Frequency	50Hz	120Hz	300Hz	1kHz	3kHz
350 ~ 450	0.8	1.0	1.1	1.3	1.4

# LARGE ALUMINUM ELECTROLYTIC CAPACITORS

## LW,SW For Welding Machine Series

- For welding machine applications
- Charge and discharge characteristic : 100000 cycles at 5 ~ 35°C
- LW series with lug terminal type, SW series with screw terminal type
- Complied to the RoHS directive



Item	Characteristics	
Operating temperature range	-25 ~ +85°C	
Capacitance tolerance	-10 ~ +50% at 120Hz, 20°C (Capacitance Tolerance "T")	
Leakage current max.	$I=3\sqrt{CV}$ (μA) (after 5 minutes)	
Dissipation factor max.	0.20 max.at 120Hz, 20°C	
Charge and discharge characteristics	After charge and discharge for 100000 cycles at 5~35°C with application of the rate voltage, the capacitors shall be satisfied the following specifications.	
	Leakage current	Less than 150% of specified value
	Capacitance change	Within ± 15% of initial value
	tanδ	Less than 150% of specified value
Conditions		
Charge resistance : 4Ω      Charge time : 1 sec		
Discharge resistance : 0.12Ω      Discharge time : 0.5sec		

### ● DRAWING

Unit : mm

#### ● LW series

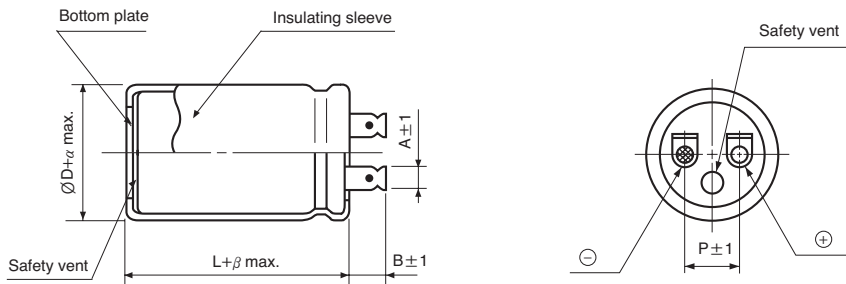

ØD	35	51
P	14	18
α	1	2
β	2	3
A	4.5	8
B	8	13

#### ● SW series

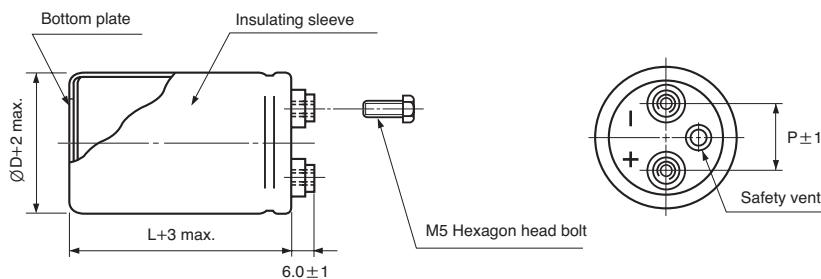

ØD	35	51	63.5	76.2
P	12.7	22	28.6	31.8

### ● DIMENSIONS

ØD×L (mm)

WV SERIES μF	315		475	
	LW	SW	LW	SW
225			51 × 100	51 × 100
330	35 × 100			
470	51 × 100			76.2 × 120
1000		63.5 × 140		76.2 × 160
1500		76.2 × 120		
2200		76.2 × 160		

# LARGE ALUMINUM ELECTROLYTIC CAPACITORS



## AM For Hi-Fi Component System Series



- For high grade audio equipment
- High resonance frequency, low ESR and low impedance
- For AMP, AVR
- Snap-in terminal type
- Voltage range of 16~100V
- Complied to the RoHS directive

Item	Characteristics				
Operating temperature range	-40 ~ +85°C				
Capacitance tolerance	±20% at 120Hz, 20°C				
Leakage current max.	$I = 3 \sqrt{CV} (\mu A)$ (after 5 minutes)				
Dissipation factor max. (at 120Hz, 20°C)	WV	16	25 ~ 35	50 ~ 71	80 ~ 100
	tanδ	0.25	0.22	0.20	0.15
Charge and discharge characteristics	After charge and discharge for 5000 cycles at 70°C with application of the rated voltage, the capacitors shall be satisfied the following specifications.				
	Appearance	No visible damage and no leakage electrolyte			
	Leakage current	Less than specified value			
	Capacitance change	Within ±15% of initial value			
	tanδ	Less than 150% of specified value			
	Conditions				
	Charge resistance : 4Ω	Applied current : 1A			
	Discharge resistance : 100Ω	Charge and discharge time : 60sec. (each)			
Load life (after application of the rated voltage for 2000 hours at 85°C)	Leakage current	Less than specified value			
	Capacitance change	Within ±20% of initial value			
	tanδ	Less than 200% of specified value			
Shelf life (at 85°C)	After 1000 hours no load test, leakage current, capacitance and tanδ are same as load life value. The measurement shall be performed at 20°C by the KS C IEC 60384 - 4				

### DRAWING

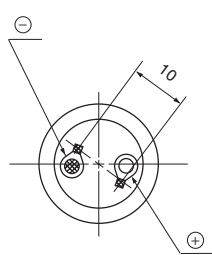
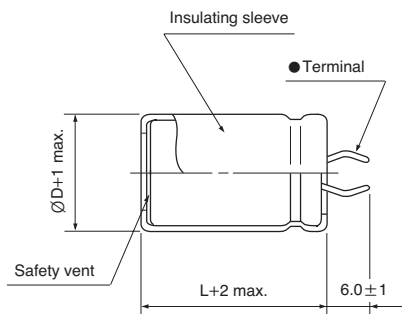

### PC Board Mounting Holes

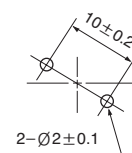

### Terminal

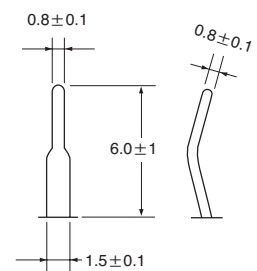

Unit : mm

### DIMENSIONS

µF	WV	ØD×L(mm)							
		16	25	35	50	63	80	100	
470								22 × 20	
680							22 × 20	25.4 × 25	
1000						22 × 20	25.4 × 25	25.4 × 30	
1500					22 × 20	25.4 × 35	25.4 × 25	30 × 35	
2200				22 × 20	25.4 × 20	25.4 × 30	30 × 30	35 × 40	
3300			22 × 25	25.4 × 25	25.4 × 25	30 × 35	30 × 30	35 × 50	
4700			25.4 × 30	25.4 × 30	30 × 40	30 × 40	35 × 40		
6800	22 × 35	25.4 × 40	30 × 25	30 × 40	35 × 50				
8200	25.4 × 30	30 × 40	35 × 30	35 × 40	35 × 50				
10000	25.4 × 35	35 × 40	35 × 35	35 × 50					
12000	30 × 40	35 × 40	35 × 40						
15000	35 × 40	35 × 50							
22000	35 × 40								
33000	35 × 60								

# LARGE ALUMINUM ELECTROLYTIC CAPACITORS

## DF For Photo Flash Series

- For photo flash applications with lug terminal
- Low dissipation factor, low leakage current and high stability during the repetition of charge and discharge
- Complied to the RoHS directive



Item	Characteristics		
Operating temperature range	-20 ~ +55°C		
Capacitance tolerance	-10 ~ +20% at 120Hz, 20°C		
Leakage current max.	$I=1 \times C$ (µA) (after 5 minutes), where C=Nominal capacitance (µF)		
Dissipation factor max. (at 120Hz, 20°C)	Capacitance range(µF)	150 ~ 600	700 ~ 1500
	tanδ	0.10	0.15
Charge and discharge characteristics	Charge and discharge at rated voltage at 5~35°C with a switch sequence of 30 seconds for 5000 times via xenon flash tube with discharge resistance of 0.7~1.0Ω		
	Leakage current	Less than 150% of specified value	
	Capacitance change	Within ± 10% of initial value	
	tanδ	Less than 150% of specified value	
Shelf life	After leaving capacitors under no load at 55°C for 1000 hours. The measurement shall be performed at 20°C by the KS C IEC 60384 - 4		
	Leakage current	Less than 300% of specified value	
	Capacitance change	Within ± 10% of initial value	
	tanδ	Less than 150% of specified value	

### DRAWING

Unit : mm

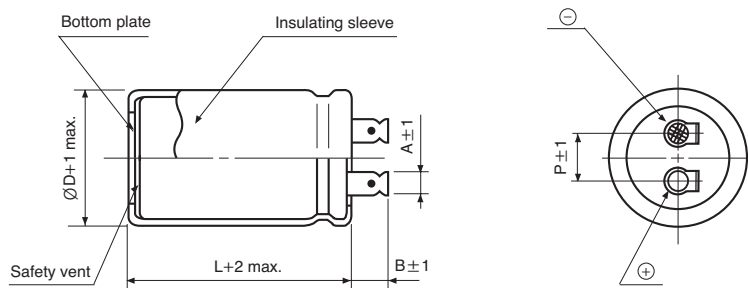

	ØD=22	ØD≥25.4	ØD=40 *
A	3.5	4.5	4.5
B	6.0	8.0	11.0
p	8.0	10.0	18.0

\* Note : Ø40 is available upon request. Please check with us individual size and dimensions.

### DIMENSIONS

ØD×L(mm)

µF	WV	330 (SV : 350)				360 (SV : 390)			
		22	25.4	30	35	22	25.4	30	35
200						22 × 30			
250		22 × 25				22 × 30			
300		22 × 30				22 × 40	25.4 × 30		
350		22 × 35				22 × 40	25.4 × 35		
400		22 × 40	25.4 × 30			22 × 45	25.4 × 35		
450		22 × 40	25.4 × 35			22 × 50	25.4 × 40		
500		22 × 45	25.4 × 35				25.4 × 45	30 × 35	
600			25.4 × 40	30 × 35			25.4 × 50	30 × 40	
700			25.4 × 45	30 × 35			25.4 × 60	30 × 45	
800			25.4 × 50	30 × 40				30 × 50	35 × 40
900				30 × 45				30 × 55	35 × 45
1000				30 × 45	35 × 40			30 × 60	35 × 55
1200				30 × 55	35 × 45			30 × 70	35 × 55
1300				30 × 60	35 × 50				35 × 60
1500				30 × 70	35 × 55				35 × 70

## AL,AY For Inverter Air-conditionings

- For high ripple current application such as air conditioning system
- AL series is load life of 5000 hours at 85°C
- AY series is load life of 7000 hours at 85°C



Item	Characteristics	
Operating temperature range	-40 ~ +85°C	
Capacitance tolerance	± 10% at 120Hz, 20°C	
Leakage current max.	$I=3\sqrt{CV}$ (μA) (after 5 minutes)	
Dissipation factor (120Hz, 20°C)	WV	450
	tanδ	0.20
Low temperature characteristics (Impedance ratio at 120Hz)	WV	450
	Z-25°C / Z+20°C	8
	Z-40°C / Z+20°C	16
Load life	The following specifications shall be satisfied when the capacitors are restored to 20°C after subjected to DC voltage with the rated ripple current is applied for 5000/7000 hours at 85°C	
	Leakage current	Less than specified value
	Capacitance change	Within ± 20% of initial value
	tanδ	Less than 200% of specified value
Shelf life	After 1000 hours no load test, leakage current, capacitance and tanδ are same as load life value. The measurement shall be performed at 20°C by the KS C IEC 60384 - 4	

### DRAWING

Unit : mm

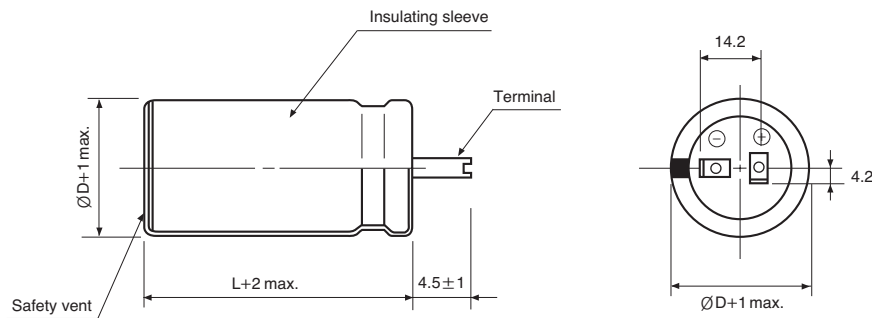

WV	WV μF	AL		AY	
		30	35	30	35
450	330				35 × 30 2.30
	390		35 × 35 2.40		35 × 35 2.70
	470	30 × 50 2.90	35 × 40 2.90		35 × 40 3.30
	560	30 × 60 4.00	35 × 50 4.00		35 × 50 4.00
	680	30 × 70 4.40	35 × 60 4.40		35 × 60 4.60
	820		35 × 70 4.80	← Case size ØD × L (mm)	35 × 70 5.40

↑  
Ripple current (A rms) at 85°C, 120Hz



# LARGE ALUMINUM ELECTROLYTIC CAPACITORS

## AZ For Inverter Air-conditionings

- For high ripple current application such as air conditioning system
- AZ series is load life of 7000 hours at 85°C

AY → **AZ**  
High Ripple



Item	Characteristics	
Operating temperature range	-40 ~ +85°C	
Capacitance tolerance	± 10% at 120Hz, 20°C	
Leakage current max.	$I=3\sqrt{CV}$ (µA) (after 5 minutes)	
Dissipation factor (120Hz, 20°C)	WV	450
	tanδ	0.20
Low temperature characteristics (Impedance ratio at 120Hz)	WV	450
	Z-25°C / Z+20°C	8
	Z-40°C / Z+20°C	16
Load life	The following specifications shall be satisfied when the capacitors are restored to 20°C after subjected to DC voltage with the rated ripple current is applied for 7000 hours at 85°C	
	Leakage current	Less than specified value
	Capacitance change	Within ±20% of initial value
Shelf life	After 1000 hours no load test, leakage current, capacitance and tanδ are same as load life value. The measurement shall be performed at 20°C by the KS C IEC 60384 - 4	

### ● DRAWING

Unit : mm

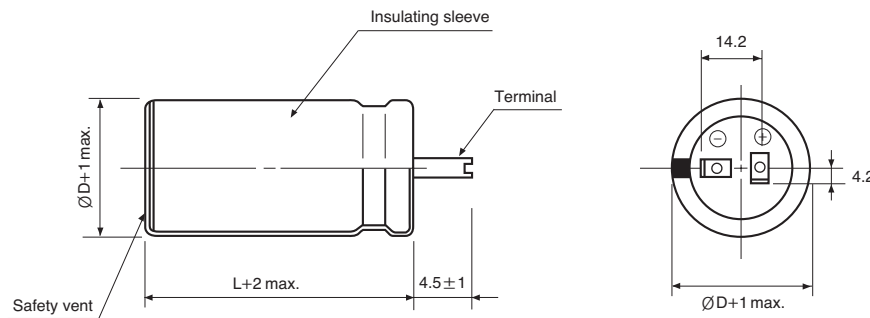

WV	µF	ØD	35	
450	330		35 × 30	2.80
	390		35 × 35	3.30
	470		35 × 40	4.00
	560		35 × 50	4.60
	680		35 × 60	5.40
	820		35 × 70	5.95

↑  
Case size ØD × L (mm)

↑  
Ripple current (A rms) at 85°C, 120Hz

## AK For Inverter Air-conditionings

- For high ripple current application such as air conditioning system
- AK series is load life of 3000 hours at 105°C



Item	Characteristics	
Operating temperature range	-40 ~ +105°C	
Capacitance tolerance	± 10% at 120Hz, 20°C	
Leakage current max.	$I=3\sqrt{CV}$ (µA) (after 5 minutes)	
Dissipation factor (120Hz, 20°C)	WV	450
	tanδ	0.20
Low temperature characteristics (Impedance ratio at 120Hz)	WV	450
	Z-25°C / Z+20°C	8
	Z-40°C / Z+20°C	16
Load life	The following specifications shall be satisfied when the capacitors are restored to 20°C after subjected to DC voltage with the rated ripple current is applied for 3000 hours at 105°C	
	Leakage current	Less than specified value
	Capacitance change	Within ± 20% of initial value
	tanδ	Less than 200% of specified value
Shelf life(at 105°C)	After 1000 hours no load test, leakage current, capacitance and tanδ are same as load life value. The measurement shall be performed at 20°C by the KS C IEC 60384 - 4	

### ● DRAWING

Unit : mm

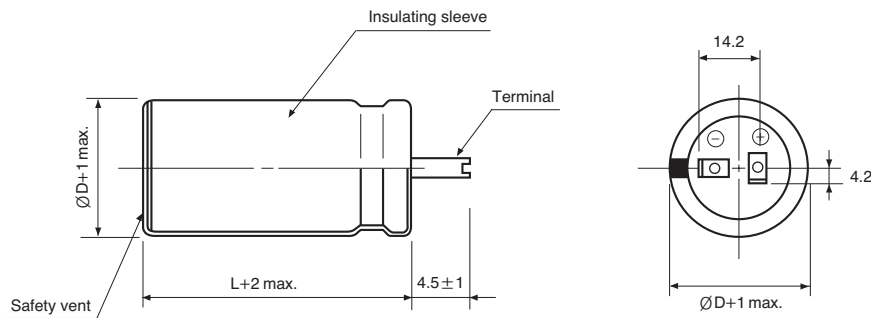

WV	µF	30		35	
		Case size	Ripple current	Case size	Ripple current
450	470	30 × 60	2.30	35 × 45	2.30
	560	30 × 60	2.85	35 × 50	2.85
	680	30 × 70	3.34	35 × 60	3.34
	820			35 × 70	3.52

Ripple current (A rms) at 105°C, 120Hz  
 Case size ØD × L (mm)

# LARGE ALUMINUM ELECTROLYTIC CAPACITORS

New **AQ** For Inverter Air-conditionings

- For high ripple current application such as air conditioning system
- AQ series is load life of 5000 hours at 105°C



AK → **AQ**  
Long Life

Item	Characteristics	
Operating temperature range	-40 ~ +105°C	
Capacitance tolerance	± 10% at 120Hz, 20°C	
Leakage current max.	$I=3 \sqrt{CV}$ (µA) (after 5 minutes)	
Dissipation factor (120Hz, 20°C)	WV	450
	tanδ	0.20
Low temperature characteristics (Impedance ratio at 120Hz)	WV	450
	Z-25°C / Z+20°C	8
	Z-40°C / Z+20°C	16
Load life	The following specifications shall be satisfied when the capacitors are restored to 20°C after subjected to DC voltage with the rated ripple current is applied for 5000 hours at 105°C	
	Leakage current	Less than specified value
	Capacitance change	Within ±20% of initial value
	tanδ	Less than 200% of specified value
Shelf life	After 1000 hours no load test, leakage current, capacitance and tanδ are same as load life value. The measurement shall be performed at 20°C by the KS C IEC 60384 - 4	

## ● DRAWING

Unit : mm

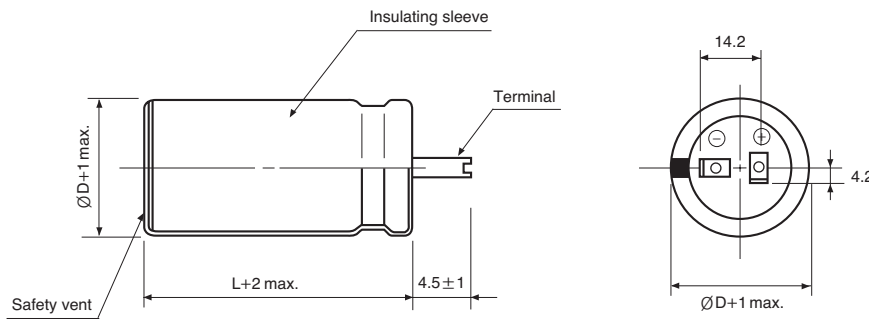

WV	µF	ØD	35	
			330	35 × 35
450	390	35 × 40	2.52	
	470	35 × 45	2.72	
	560	35 × 50	2.92	
	680	35 × 60	3.52	
	820	35 × 70	3.80	

↑  
Case size ØD×L (mm)

↑  
Ripple current (A rms) at 105°C, 120Hz